

SHEET TITLE

01	COVER SHEET
02	BOM & PCB MODIFY HISTORY
03	BLOCK DIAGRAM
04	CPU_LGA1155-A
05	CPU_LGA1155-B
06	CPU_LGA1155-C
07	DDR III CHANNEL A
08	DDR III CHANNEL B
09	PCH_FDI,DMI,USB,PCIE,NVRAM
10	PCH_DP,CLK BUFFER
11	PCH_HOST,SATA,PCI
12	PCH_GPIO,CTRL,AUDIO
13	PCH_PWR,GND
14	PCI EXPRESS*16 SLOT
15	PCI EXPRESS*1x2 SLOT
16	ITE 8620 LPC IO
17	KB_MS,R_USB,-PROCHOT
18	HWM,FAN CTRL,OV
19	Dual BIOS
20	FP,FUSB,SPK,SATALED
21	ALC887
22	REAR AUDIO JACK
23	REALTEK 8111F/USB_LAN
24	DISCRETE POWER
25	ATX,-S_WARN,-S_ACK,5VDUAL
26	CPU_VTT
27	VCORE INTERSIL_95836_1

SHEET TITLE

28	VCORE INTERSIL_95836_2
29	VCORE INTERSIL_95836_3
30	LPT

Gigabyte Confidential  
Do not Copy



# BLOCK DIAGRAM

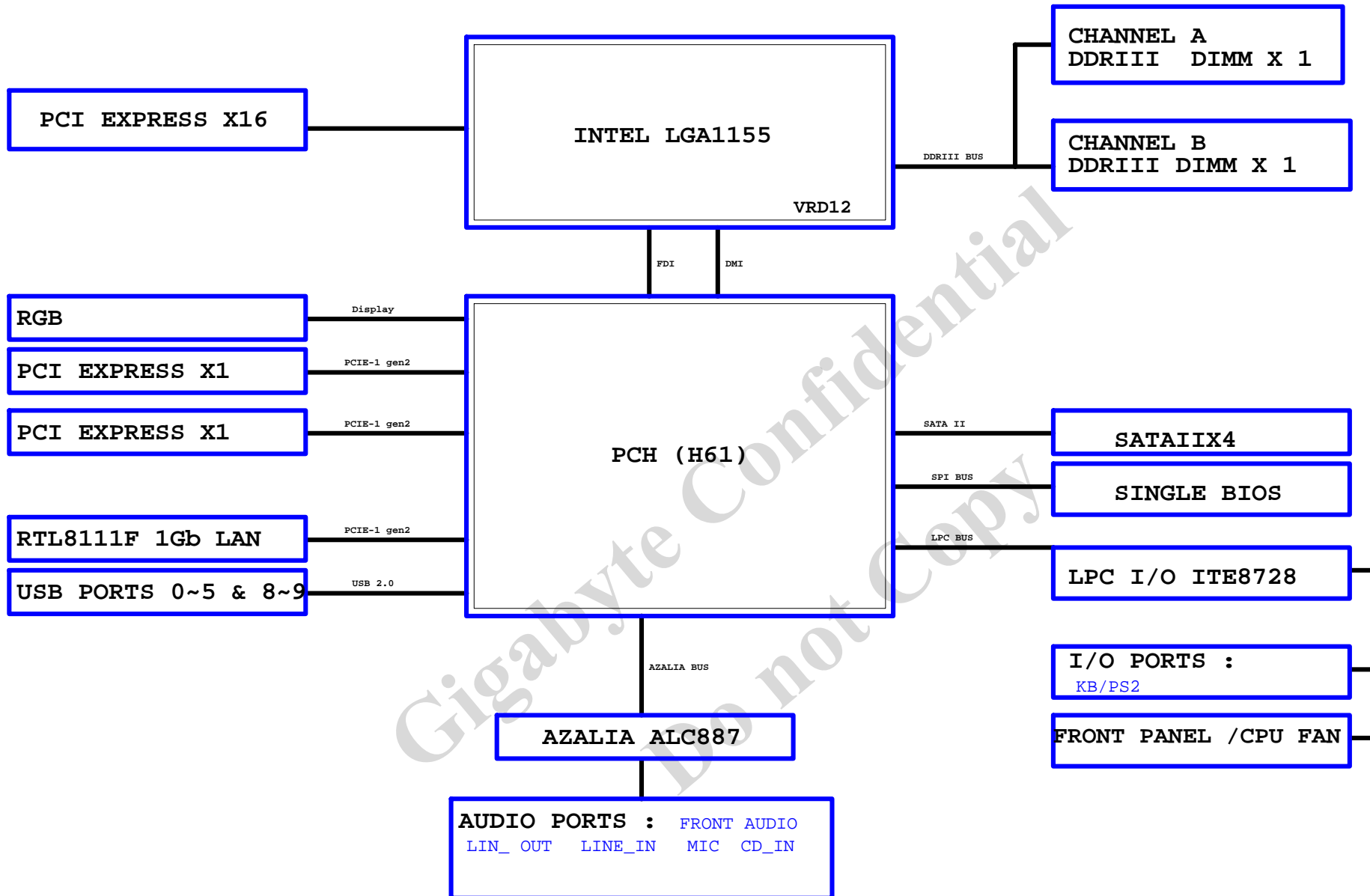

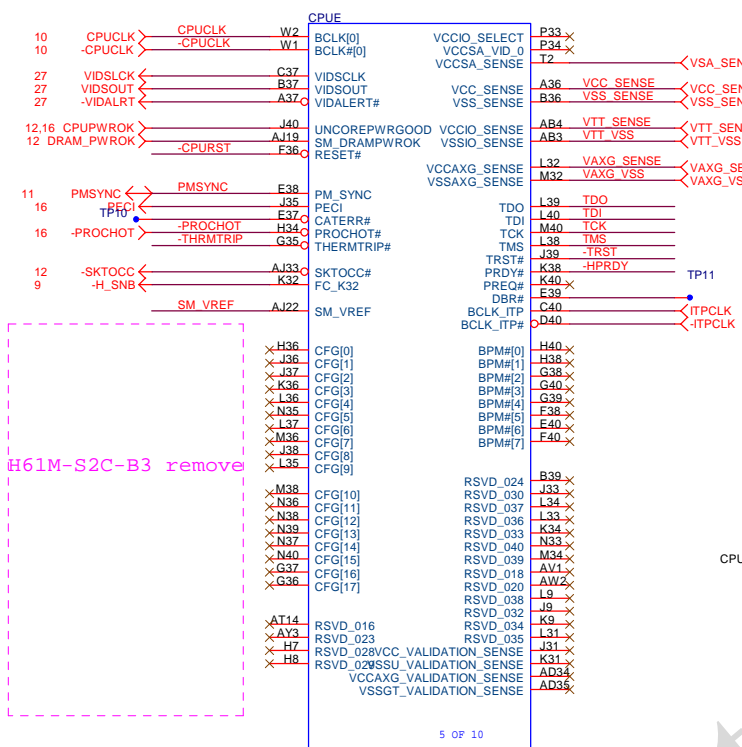
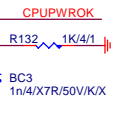

CFG	H	L	NOTE
0	RSVD	RSVD	RSVD
1	RSVD	RSVD	RSVD
2	NORM	Reverse	LANE REVERSAL[0], x16
3	RSVD	RSVD	RSVD
4	RSVD	RSVD	RSVD
7	RSVD	RSVD	RSVD
8	RSVD	RSVD	RSVD
9	RSVD	RSVD	RSVD
10	RSVD	RSVD	RSVD
11	RSVD	RSVD	RSVD
12	RSVD	RSVD	RSVD
13	RSVD	RSVD	RSVD
14	RSVD	RSVD	RSVD
15	RSVD	RSVD	RSVD
16	RSVD	RSVD	RSVD
17	RSVD	RSVD	RSVD

CFG6	CFG5	PCIE CONFIG
1	1	1x16, Default
1	0	Z8
0	0	RSVD
0	0	X8, X4, X4

CFG 0-17 all internal PULL-UP

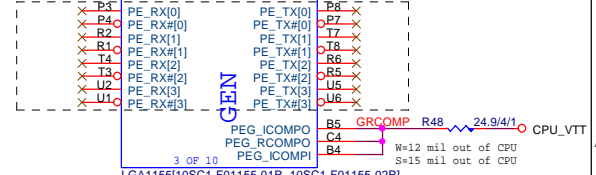
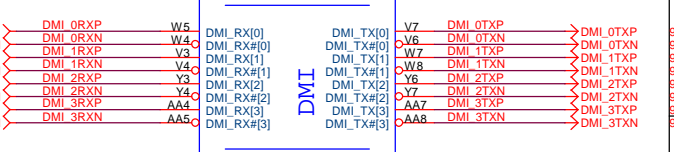
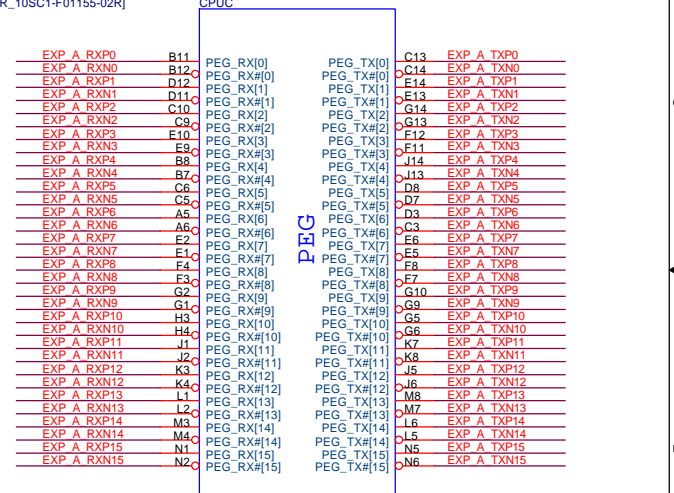
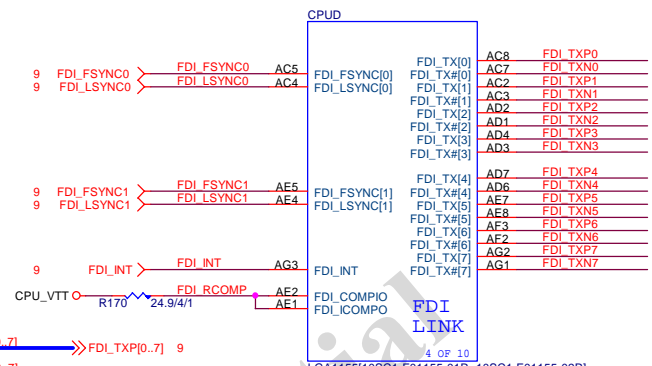
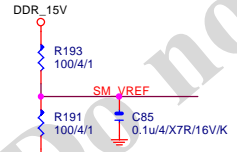
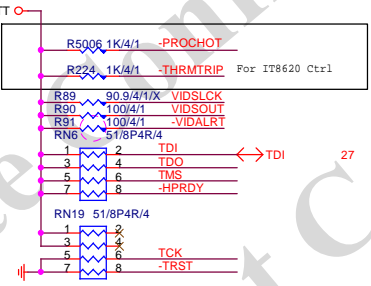
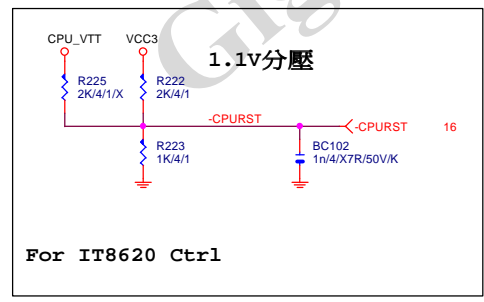
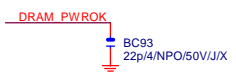

**Gigabyte Technology**

Title: **CPU LGA1155-A**

Size	Document Number	Rev
Custom	<b>GA-H61M-DS2</b>	<b>4.01</b>

Date: Wednesday, September 25, 2013 Sheet 4 of 30

CPUA			
MAAA0	AV27	SA_MA[0]	SA_DQS[0]
MAAA1	AY24	SA_MA[1]	SA_DQS#0
MAAA2	AW24	SA_MA[2]	
MAAA3	AW23	SA_MA[3]	
MAAA4	AV23	SA_MA[4]	AJ3 MDA0
MAAA5	AT24	SA_MA[5]	AJ4 MDA1
MAAA6	AT23	SA_MA[6]	AL3 MDA2
MAAA7	AU22	SA_MA[7]	AL4 MDA3
MAAA8	AV22	SA_MA[8]	AJ2 MDA4
MAAA9	AT22	SA_MA[9]	AJ1 MDA5
MAAA10	AV28	SA_MA[10]	AL2 MDA6
MAAA11	AU21	SA_MA[11]	AL1 MDA7
MAAA12	AT21	SA_MA[12]	
MAAA13	AW32	SA_MA[13]	AP3 DQSA1
MAAA14	AU20	SA_MA[14]	AP2 -DQSA1
MAAA15	AT20	SA_MA[15]	
7	-SWEA	-SCASA	AV29 SA_WE#
7	-SRASA	-SRASA	AV28 SA_CAS#
7	SBA00	SBA00	AY29 SA_BS[0]
7	SBA01	SBA01	AW28 SA_BS[1]
7	SBA02	SBA02	AV20 SA_BS[2]
7	-CSA0	-CSA0	AU29 SA_CS#0
7	-CSA1	-CSA1	AV32 SA_CS#1
7	CKEA0	CKEA0	AT19 SA_CKE[0]
7	CKEA1	CKEA1	AT18 SA_CKE[1]
7			AV18 SA_CKE[2]
7			AV18 SA_CKE[3]
7	MODT_A0	MODT_A0	AV31 SA_ODT[0]
7	MODT_A1	MODT_A1	AU32 SA_ODT[1]
7			AU30 SA_ODT[2]
7			AW33 SA_ODT[3]
7	DCLKA0	DCLKA0	AY25 SA_CK[0]
7	-DCLKA0	-DCLKA0	AW25 SA_CK#0
7	DCLKA1	DCLKA1	AU24 SA_CK[1]
7	-DCLKA1	-DCLKA1	AU25 SA_CK#1
7			AW27 SA_CK[2]
7			AY27 SA_CK#2
7			AV26 SA_CK[3]
7			AW26 SA_CK#3
7.8	-DDR3_RST		AW18 SM_DRAMRST#
			AV13 SA_DQS[8]
			AV12 SA_DQS#8
			AU12 SA_ECC_CB[0]
			AU14 SA_ECC_CB[1]
			AW13 SA_ECC_CB[2]
			AY13 SA_ECC_CB[3]
			AU11 SA_ECC_CB[4]
			AY12 SA_ECC_CB[5]
			AW12 SA_ECC_CB[6]
			AR40 MDA40
			AR37 MDA41
			AN38 MDA42
			AN37 MDA43
			AR39 MDA44
			AR38 MDA45
			AN39 MDA46
			AN40 MDA47
			AK38 DQSA6
			AK39 -DQSA6
			AL40 MDA48
			AL37 MDA49
			AJ38 MDA50
			AJ37 MDA51
			AL39 MDA52
			AL38 MDA53
			AJ39 MDA54
			AJ40 MDA55
			AF38 DQSA7
			AF39 -DQSA7
			AG40 MDA56
			AG37 MDA57
			AE38 MDA58
			AE37 MDA59
			AG39 MDA60
			AG38 MDA61
			AE39 MDA62
			AE40 MDA63
			MODT_A0[.1] MODT_A0_11
			MODT_B0[.1] MODT_B0_11
			MDA[0..63] MDA[0..63]
			MDB[0..63] MDB[0..63]
			DQSA[0..7] DQSA[0..7]
			-DQSA[0..7] -DQSA[0..7]
			MAAA[0..15] MAAA[0..15]
			MAAB[0..15] MAAB[0..15]
			DQSB[0..7] DQSB[0..7]
			-DQSB[0..7] -DQSB[0..7]

DDR\_0

1 OF 10

LGA1155[10SC1-F01155-01R\_10SC1-F01155-02R]

CPUB			
MAAB0	AK24	SB_MA[0]	SB_DQS[0]
MAAB1	AM20	SB_MA[1]	SB_DQS#0
MAAB2	AM19	SB_MA[2]	
MAAB3	AK18	SB_MA[3]	
MAAB4	AP19	SB_MA[4]	AG7 MDB0
MAAB5	AP18	SB_MA[5]	AG8 MDB1
MAAB6	AM18	SB_MA[6]	AJ9 MDB2
MAAB7	AL18	SB_MA[7]	AJ8 MDB3
MAAB8	AN18	SB_MA[8]	AG5 MDB4
MAAB9	AY17	SB_MA[9]	AG6 MDB5
MAAB10	AN23	SB_MA[10]	AJ6 MDB6
MAAB11	AU17	SB_MA[11]	AJ7 MDB7
MAAB12	AT18	SB_MA[12]	
MAAB13	AR26	SB_MA[13]	AM8 DQSB1
MAAB14	AY16	SB_MA[14]	AL8 -DQSB1
MAAB15	AV16	SB_MA[15]	
7	-SWEB	-SCASB	AR25 SB_WE#
7	-SRASB	-SRASB	AP24 SB_CAS#
7	SBAB0	SBAB0	AP23 SB_BS[0]
7	SBAB1	SBAB1	AW17 SB_BS[1]
7	SBAB2	SBAB2	AW17 SB_BS[2]
7	-CSB0	-CSB0	AN25 SB_CS#0
7	-CSB1	-CSB1	AN26 SB_CS#1
7	CKEB0	CKEB0	AU16 SB_CKE[0]
7	CKEB1	CKEB1	AV16 SB_CKE[1]
7			AW15 SB_CKE[2]
7			AV15 SB_CKE[3]
7	MODT_B0	MODT_B0	AL26 SB_ODT[0]
7	MODT_B1	MODT_B1	AP26 SB_ODT[1]
7			AM26 SB_ODT[2]
7			AK26 SB_ODT[3]
7	DCLKB0	DCLKB0	AL21 SB_CK[0]
7	-DCLKB0	-DCLKB0	AL22 SB_CK#0
7	DCLKB1	DCLKB1	AK20 SB_CK[1]
7	-DCLKB1	-DCLKB1	AK20 SB_CK#1
7			AL23 SB_CK[2]
7			AM22 SB_CK[2]
7			AV7 SB_CK[3]
7			AP21 SB_CK#3
7			AN21 SB_CK#3
7	VREF_DQB		AH1 FC_AH1
7	VREF_DOA		AH4 FC_AH4
			AR28 MDB32
			AM33 MDB33
			AR29 MDB34
			AL28 MDB35
			AL29 MDB36
			AP28 MDB37
			AM28 MDB38
			AM29 MDB39
			AP33 DQSB5
			AR33 -DQSB5
			AP32 MDB40
			AP21 MDB41
			AP35 MDB42
			AP34 MDB43
			AR32 MDB44
			AR31 MDB45
			AR35 MDB46
			AR34 MDB47
			AL33 DQSB6
			AM33 -DQSB6
			AM32 MDB48
			AM31 MDB49
			AL35 MDB50
			AL32 MDB51
			AM34 MDB52
			AL31 MDB53
			AM35 MDB54
			AL34 MDB55
			AG35 DQSB7
			AG34 -DQSB7
			AH35 MDB56
			AH34 MDB57
			AE34 MDB58
			AE35 MDB59
			AJ35 MDB60
			AJ34 MDB61
			AF33 MDB62
			AF35 MDB63

DDR\_1

2 OF 10

LGA1155[10SC1-F01155-01R\_10SC1-F01155-02R]

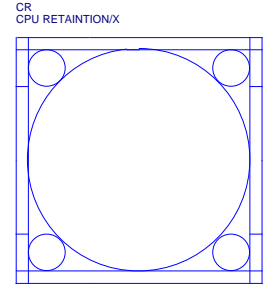

Need check the new CPU ME

CPU



ILM\_BP/1156/CSP/[12KRC-0F0001-31R]

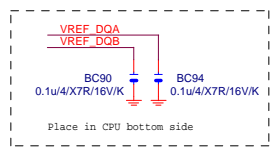

Place in CPU bottom side

Gigabyte Technology

Title		CPU LGA1156-B	
Size	Document Number	GA-H61M-DS2	
Custom			Rev 4.01
Date:	Wednesday, September 25, 2013	Sheet	5 of 30

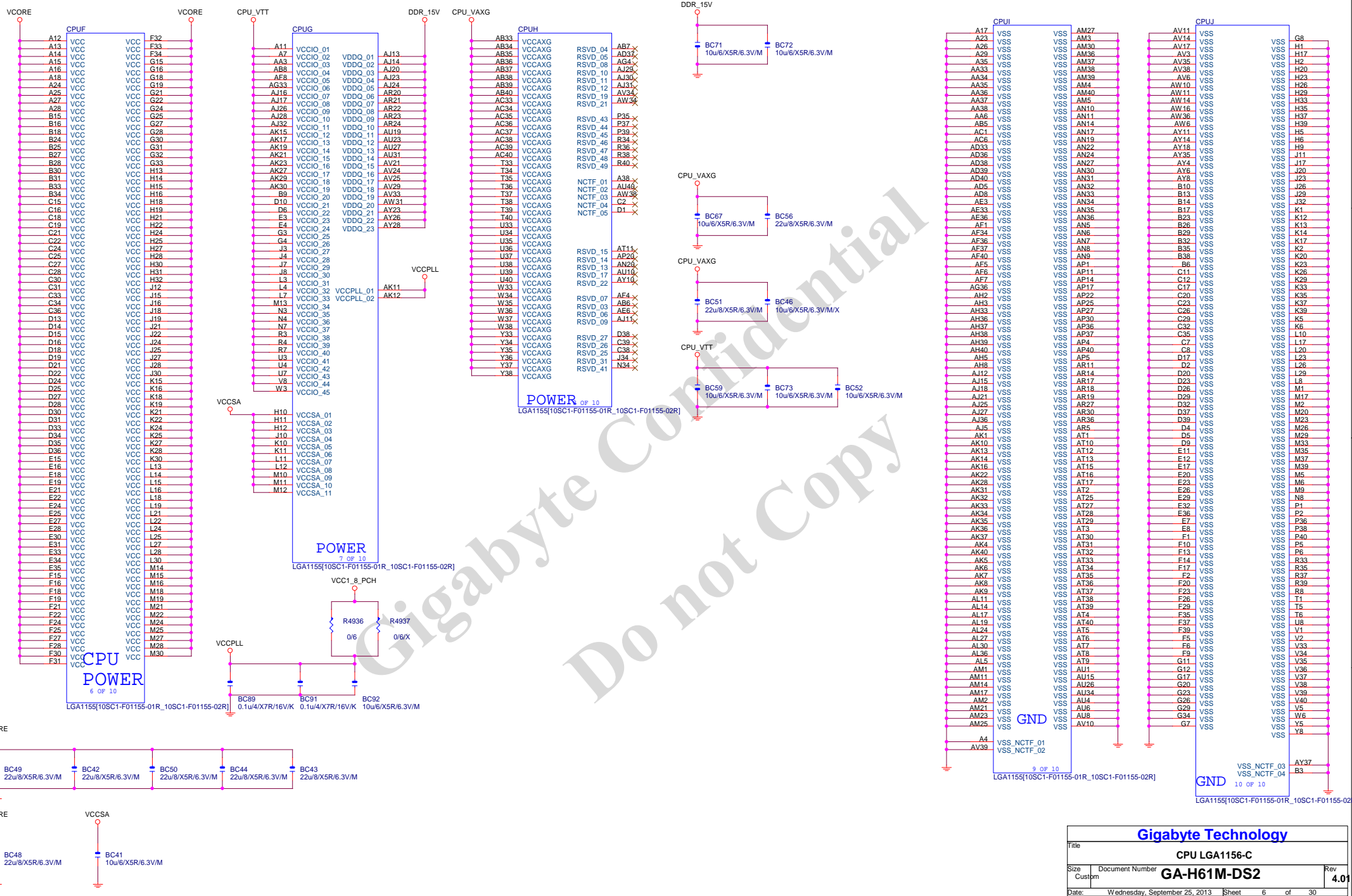

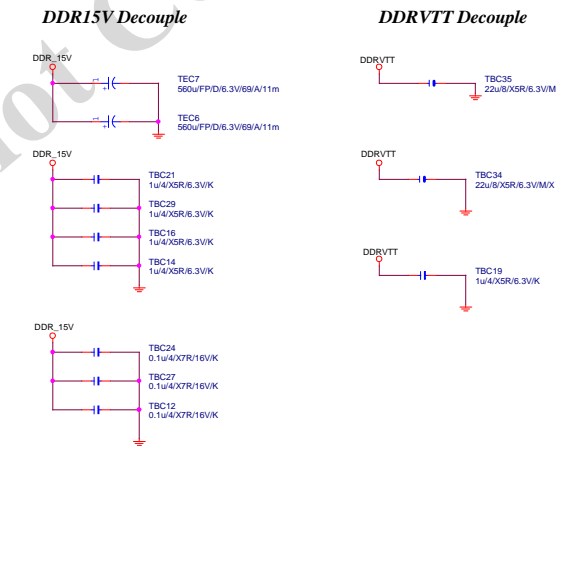
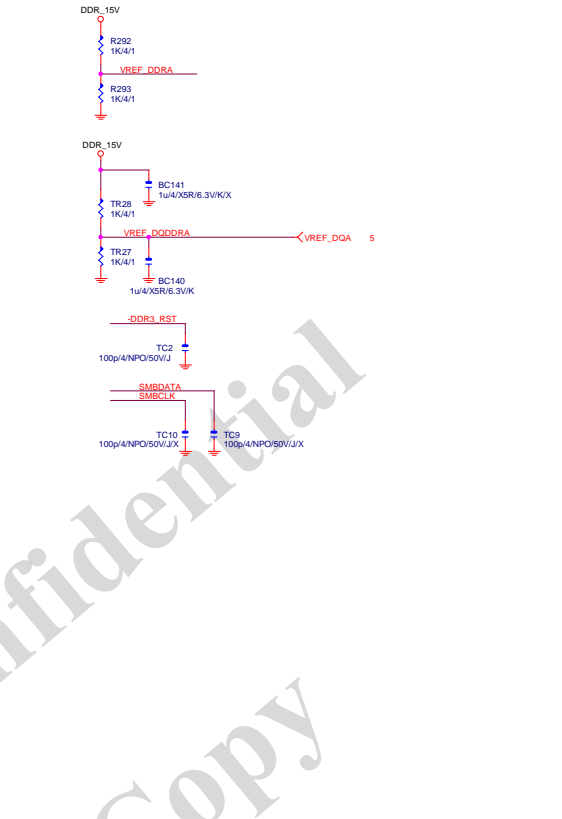
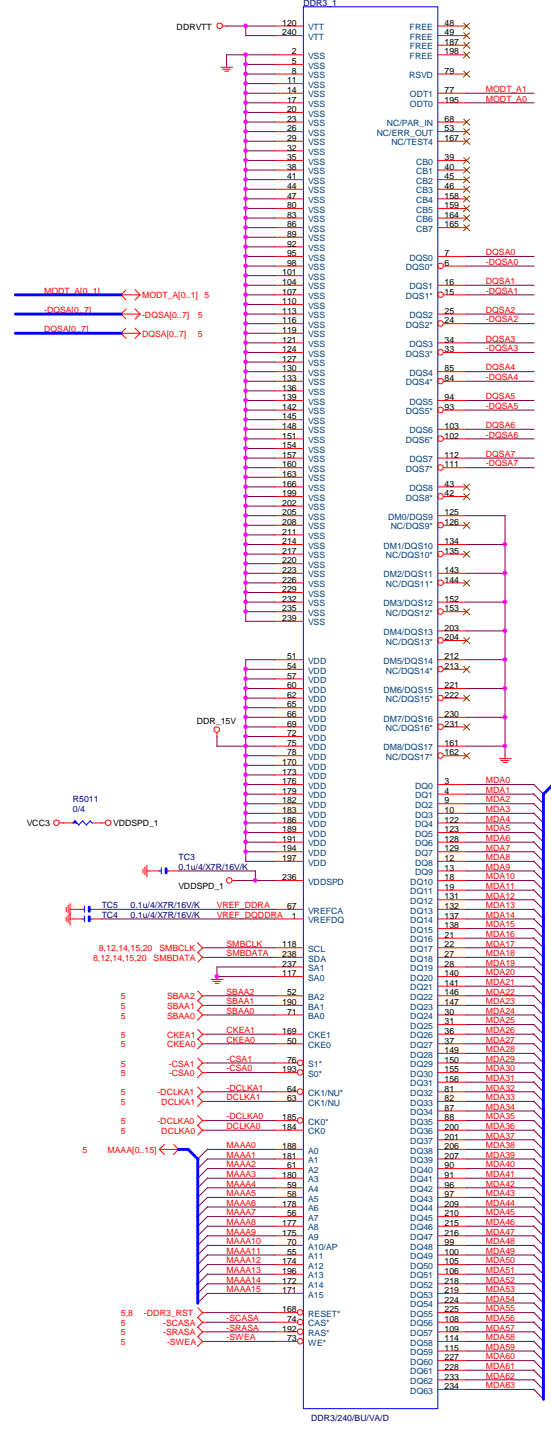

<b>Gigabyte Technology</b>			
Title: <b>DDRIII CHANNEL A</b>			
Size	Document Number	Rev	
Custpm	<b>GA-H61M-DS2</b>	<b>4.01</b>	
Date:	Sheet	7 of 30	



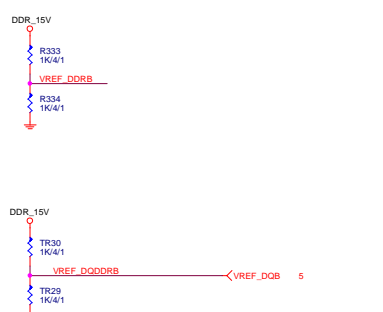
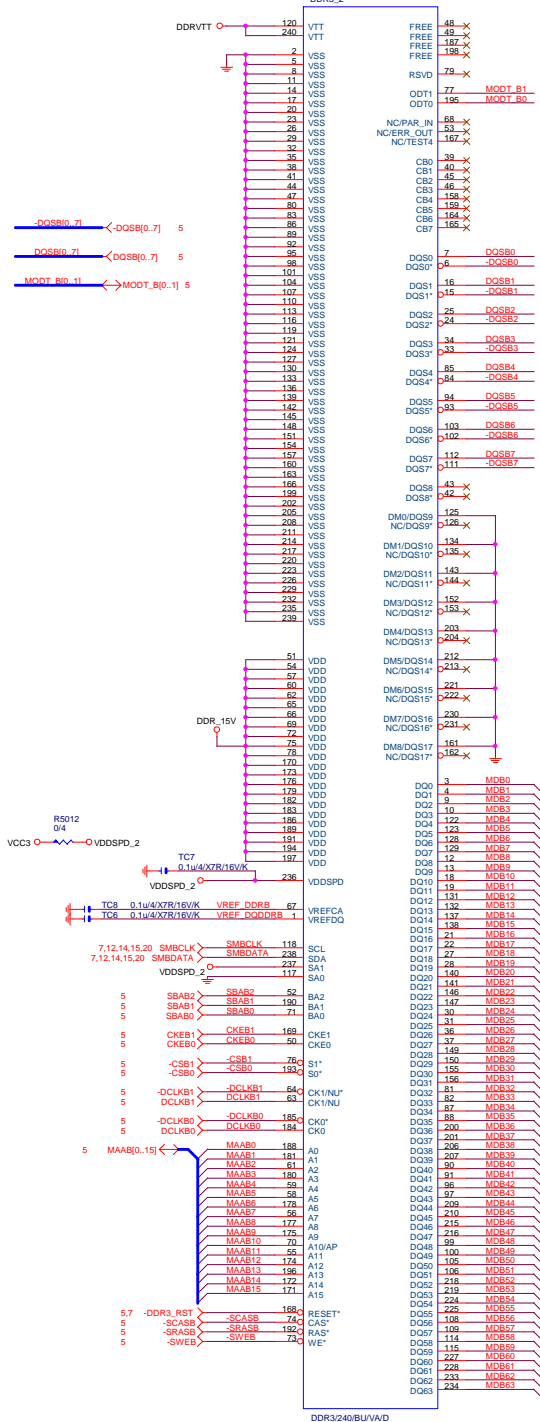

Gigabyte Confidential  
Do not Copy



CPU

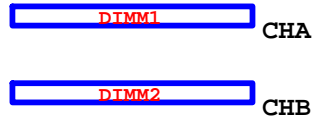

<b>Gigabyte Technology</b>		
Title DDRIII CHANNEL B		
Size	Document Number	Rev
Custom	GA-H61M-DS2	4.01
Date:	Sheet 8 of 30	















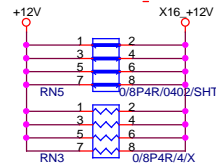
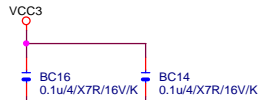

- EXP A\_RXP0\_15] >> EXP\_A\_RXP[0..15] 4
- EXP A\_RXN0\_15] >> EXP\_A\_RXN[0..15] 4
- EXP A\_TXP0\_15] >> EXP\_A\_TXP[0..15] 4
- EXP A\_TXN0\_15] >> EXP\_A\_TXN[0..15] 4

EXP A_TXP0	C22	0.22u/4/X5R/6.3V/K	EXP A_TXP0C
EXP A_TXN0	C26	0.22u/4/X5R/6.3V/K	EXP A_TXN0C
EXP A_TXP1	C29	0.22u/4/X5R/6.3V/K	EXP A_TXP1C
EXP A_TXN1	C31	0.22u/4/X5R/6.3V/K	EXP A_TXN1C
EXP A_TXP2	C33	0.22u/4/X5R/6.3V/K	EXP A_TXP2C
EXP A_TXN2	C35	0.22u/4/X5R/6.3V/K	EXP A_TXN2C
EXP A_TXP3	C37	0.22u/4/X5R/6.3V/K	EXP A_TXP3C
EXP A_TXN3	C40	0.22u/4/X5R/6.3V/K	EXP A_TXN3C
EXP A_TXP4	C48	0.22u/4/X5R/6.3V/K	EXP A_TXP4C
EXP A_TXN4	C49	0.22u/4/X5R/6.3V/K	EXP A_TXN4C
EXP A_TXP5	C52	0.22u/4/X5R/6.3V/K	EXP A_TXP5C
EXP A_TXN5	C54	0.22u/4/X5R/6.3V/K	EXP A_TXN5C
EXP A_TXP6	C56	0.22u/4/X5R/6.3V/K	EXP A_TXP6C
EXP A_TXN6	C58	0.22u/4/X5R/6.3V/K	EXP A_TXN6C
EXP A_TXP7	C60	0.22u/4/X5R/6.3V/K	EXP A_TXP7C
EXP A_TXN7	C61	0.22u/4/X5R/6.3V/K	EXP A_TXN7C
EXP A_TXP8	C63	0.22u/4/X5R/6.3V/K	EXP A_TXP8C
EXP A_TXN8	C64	0.22u/4/X5R/6.3V/K	EXP A_TXN8C
EXP A_TXP9	C66	0.22u/4/X5R/6.3V/K	EXP A_TXP9C
EXP A_TXN9	C67	0.22u/4/X5R/6.3V/K	EXP A_TXN9C
EXP A_TXP10	C69	0.22u/4/X5R/6.3V/K	EXP A_TXP10C
EXP A_TXN10	C70	0.22u/4/X5R/6.3V/K	EXP A_TXN10C
EXP A_TXP11	C71	0.22u/4/X5R/6.3V/K	EXP A_TXP11C
EXP A_TXN11	C72	0.22u/4/X5R/6.3V/K	EXP A_TXN11C
EXP A_TXP12	C74	0.22u/4/X5R/6.3V/K	EXP A_TXP12C
EXP A_TXN12	C75	0.22u/4/X5R/6.3V/K	EXP A_TXN12C
EXP A_TXP13	C77	0.22u/4/X5R/6.3V/K	EXP A_TXP13C
EXP A_TXN13	C78	0.22u/4/X5R/6.3V/K	EXP A_TXN13C
EXP A_TXP14	C79	0.22u/4/X5R/6.3V/K	EXP A_TXP14C
EXP A_TXN14	C80	0.22u/4/X5R/6.3V/K	EXP A_TXN14C
EXP A_TXP15	C82	0.22u/4/X5R/6.3V/K	EXP A_TXP15C
EXP A_TXN15	C83	0.22u/4/X5R/6.3V/K	EXP A_TXN15C

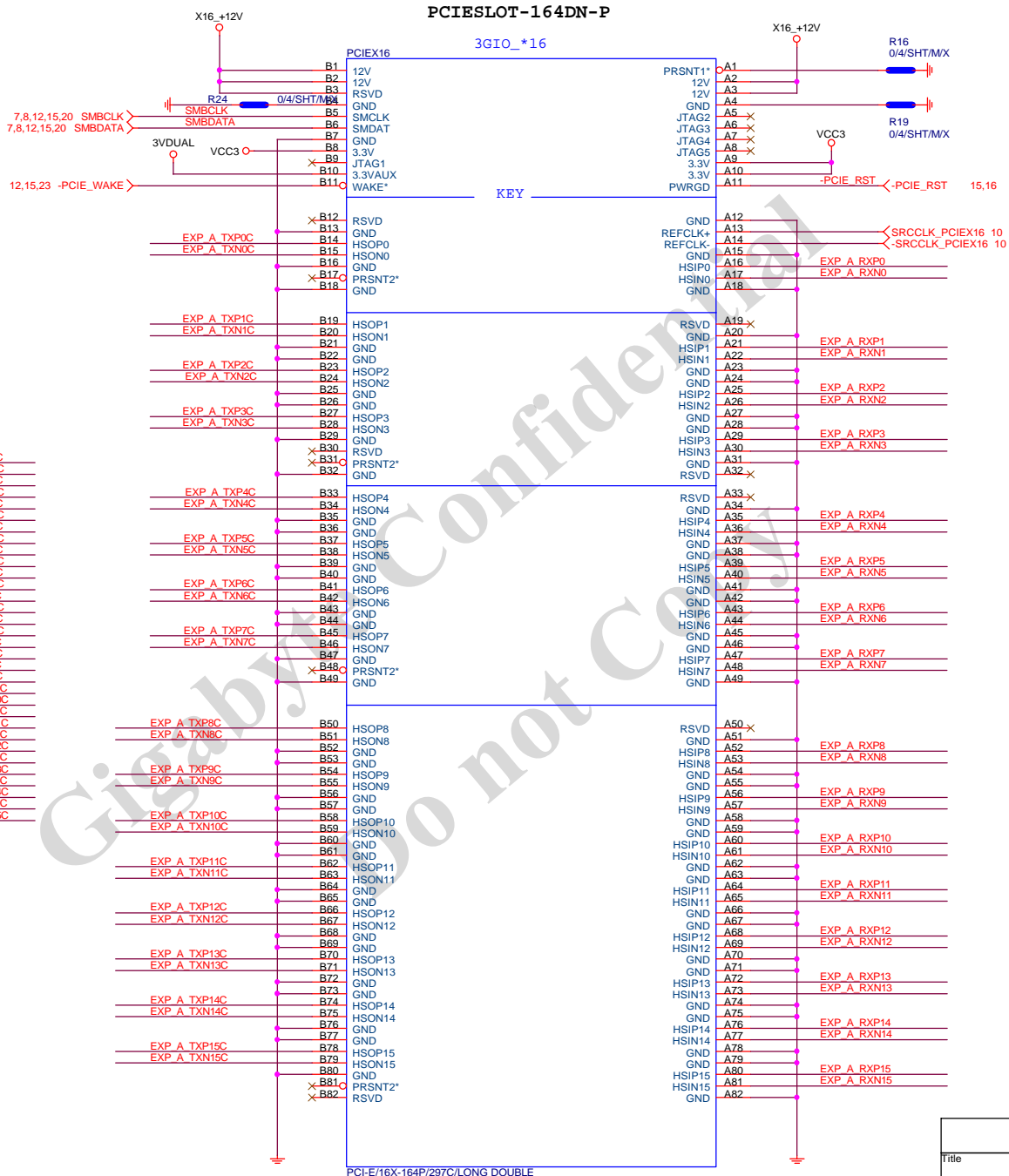

PCI-E/16X-164P/297C/LONG DOUBLE  
 PCI-E/16X-164P/297C/LONG DOUBL

<b>Gigabyte Technology</b>		
Title <b>PCI EXPRESS * 16</b>		
Size Custom	Document Number <b>GA-H61M-DS2</b>	Rev <b>4.01</b>
Date:	Wednesday, September 25, 2013	Sheet 14 of 30

PCIE\*1

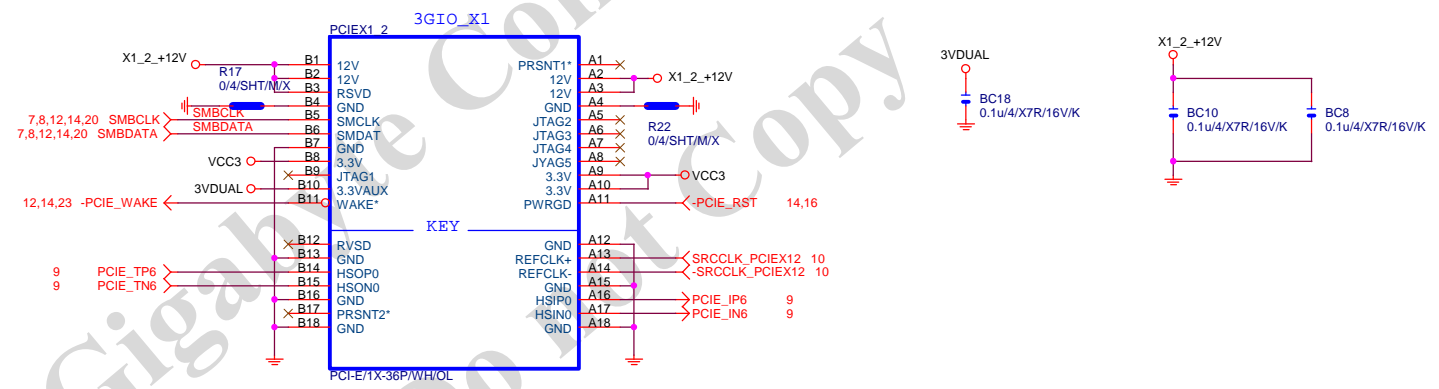
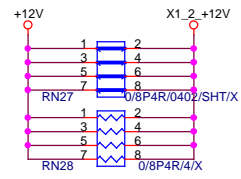
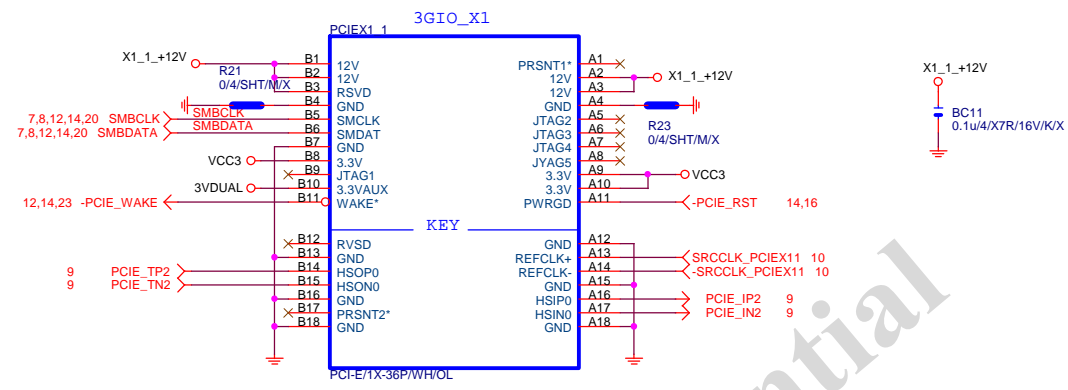
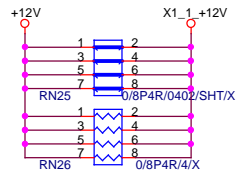

<b>Gigabyte Technology</b>			
<b>PCIEX1,X2/CLK GEN</b>			
Size Custom	Document Number	<b>GA-H61M-DS2</b>	Rev <b>4.01</b>
Date:	Wednesday, September 25, 2013	Sheet 15 of 30	



GP22 Default GP22 DIOD8  
GP23 Default CPU\_PG DOD8

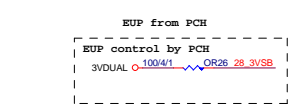
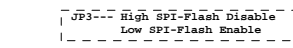
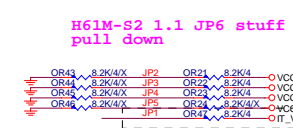
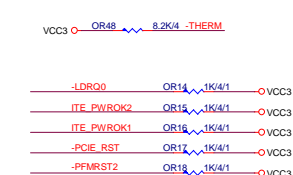
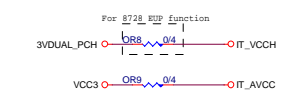
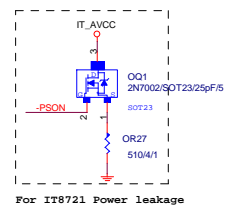
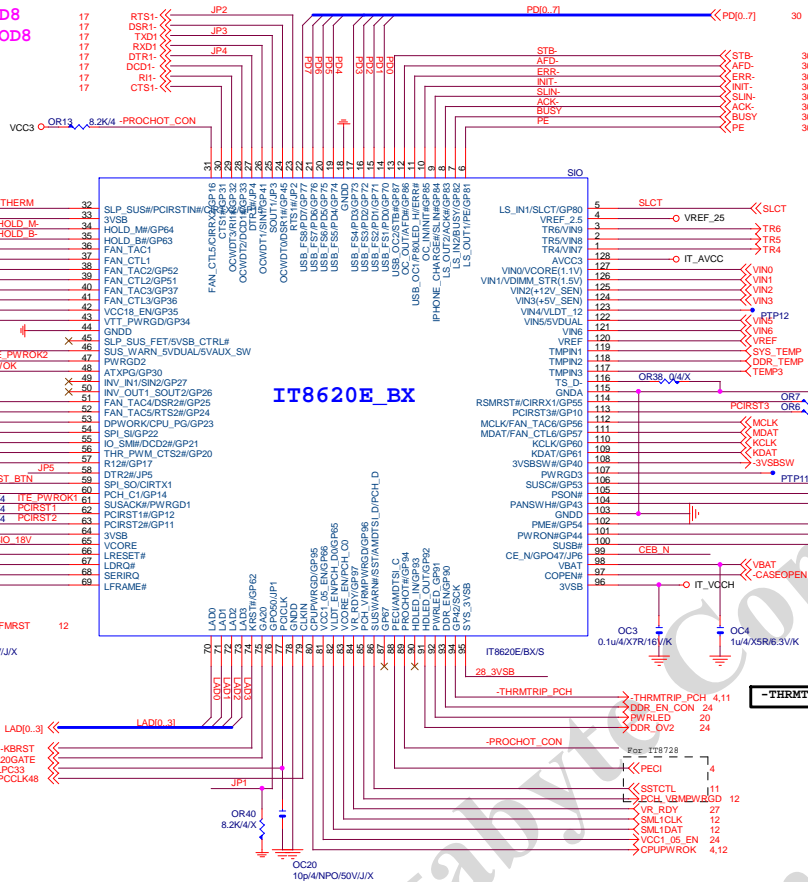

-PROCHOT

-THERMTRIP

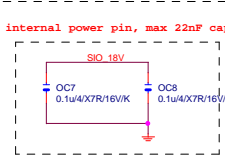
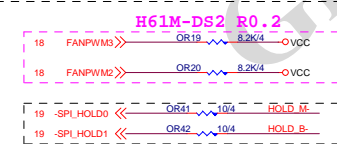

IT8728	
PIN121	VCORE_EN/PCH_C0
PIN120	VLDT_EN/PCH_D0
PIN19	ATXPG
PIN31	PCH_C1
PIN53	SST/ANDTSL_D/MTRB#/PCH_D1
PIN55	PECI/ANDTSL_C/DRV98
PIN66	SYS_3VSB
PIN70	GP47
PIN95	VIN2(VCC5)
PIN96	VIN1(VCC12)
PIN97	VIN1/VDIMM_STK(1.5V)
PIN98	VIN0/VCORE(1.1V)/NC

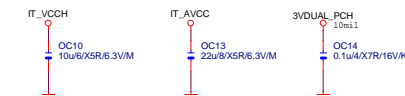

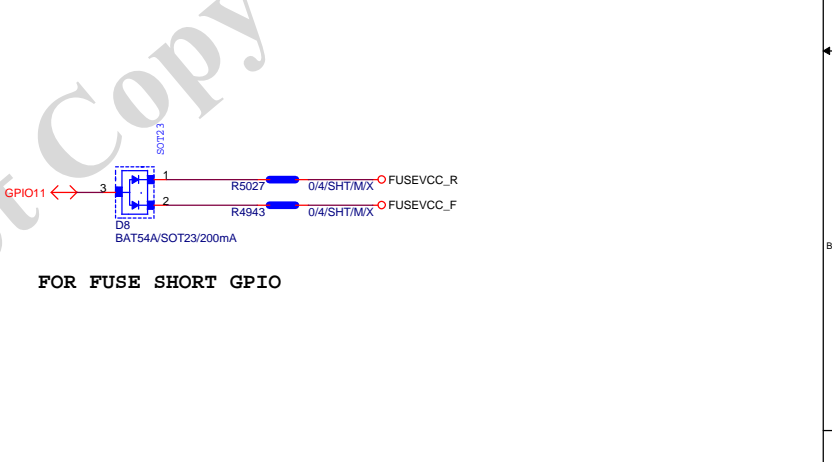
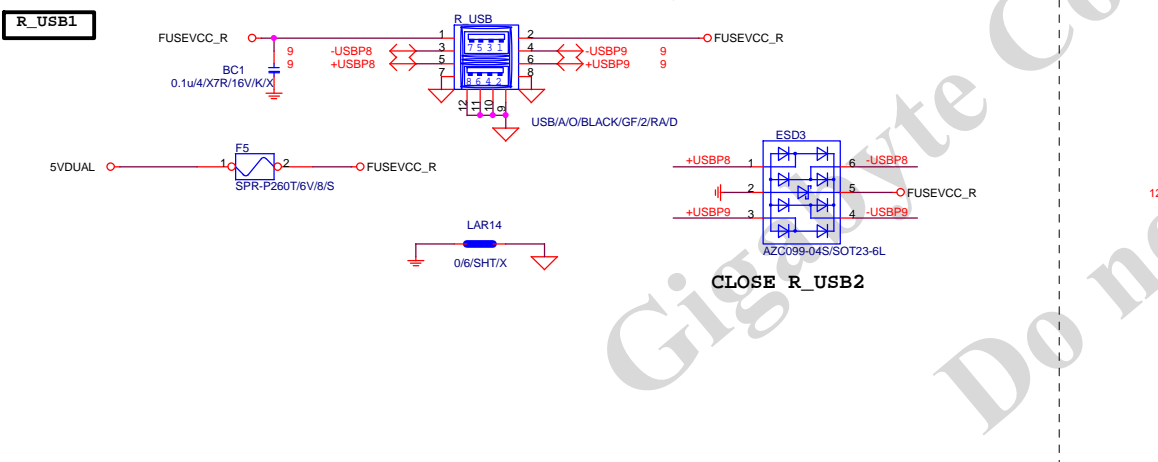
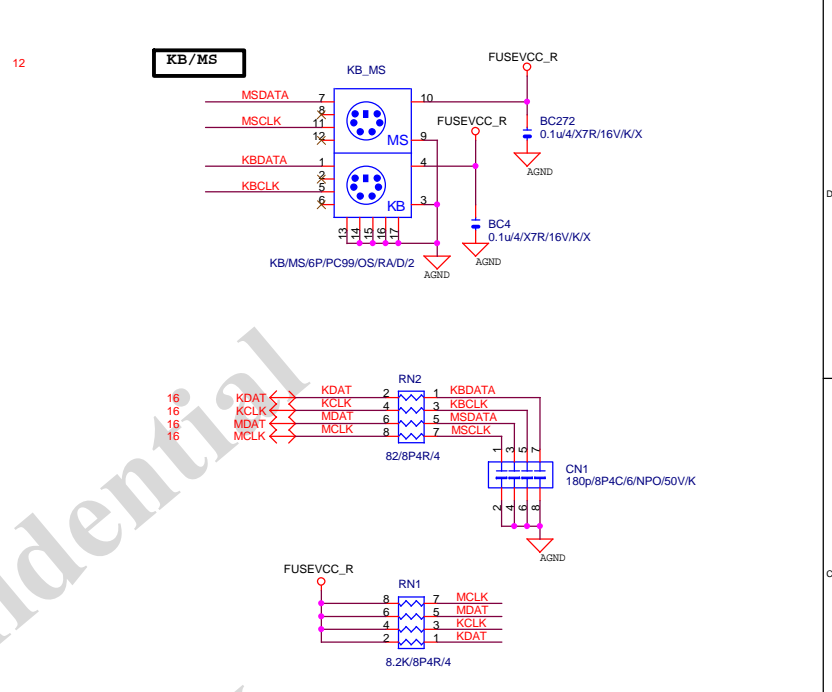
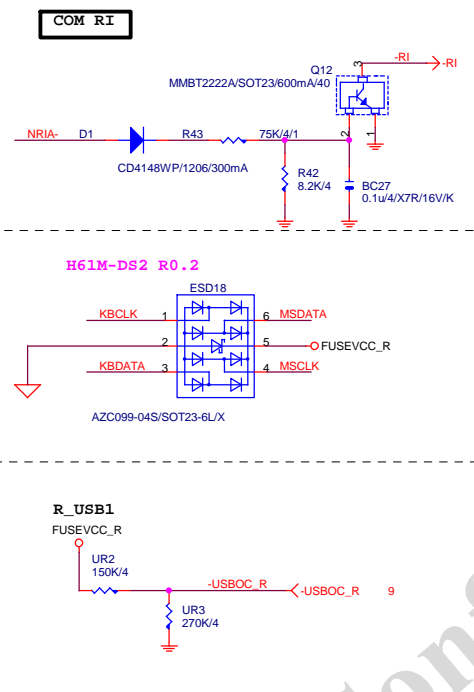
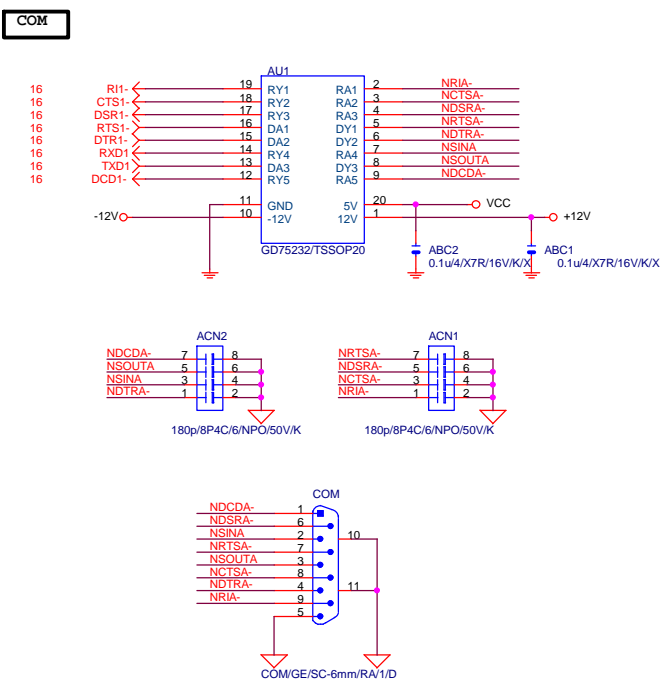

**TEMP H/W MONITOR**

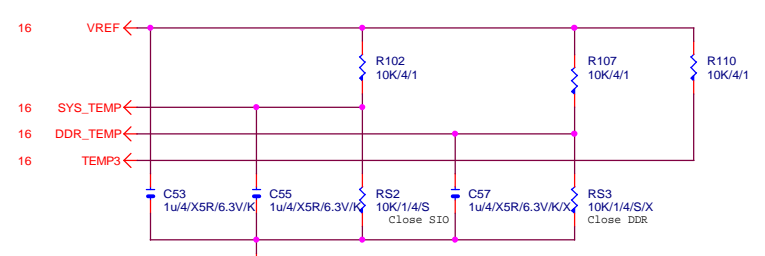

**CASE OPEN**

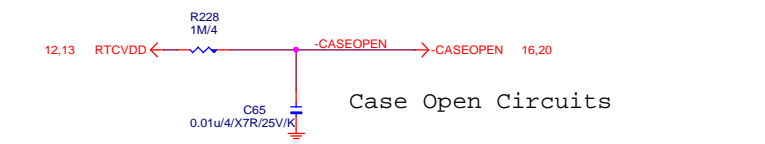

**VOLTAGE-- H/W MONITOR**

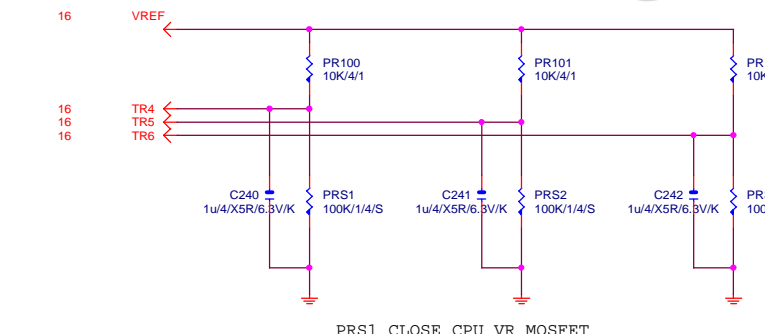
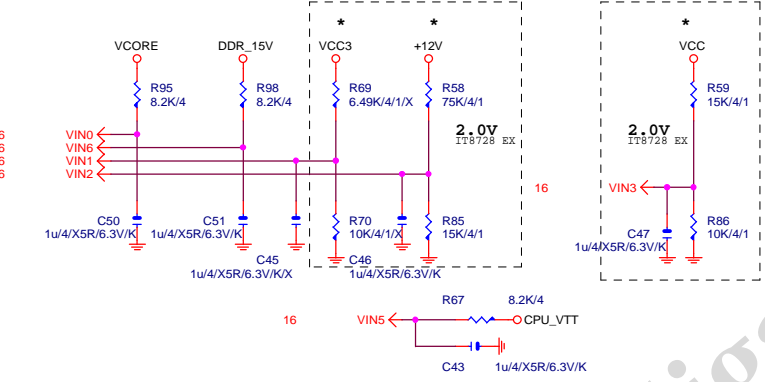

PRS1 CLOSE CPU VR MOSFET

**CPU SMART FAN**

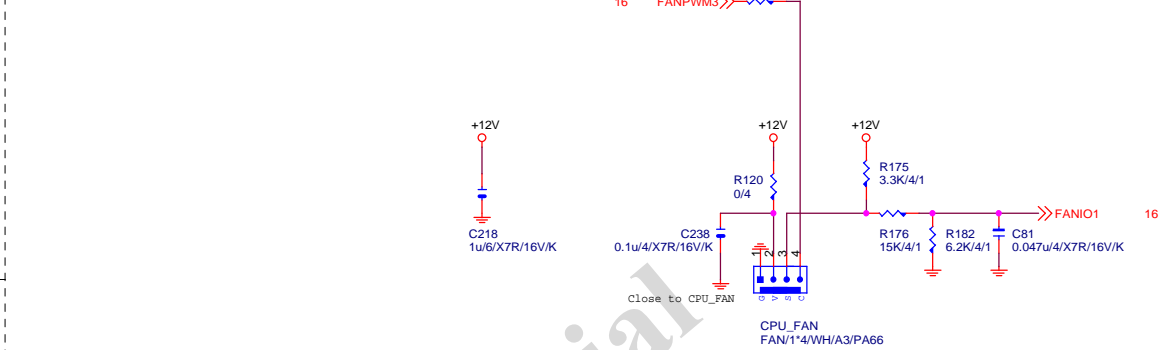

**SYS SMART FAN**

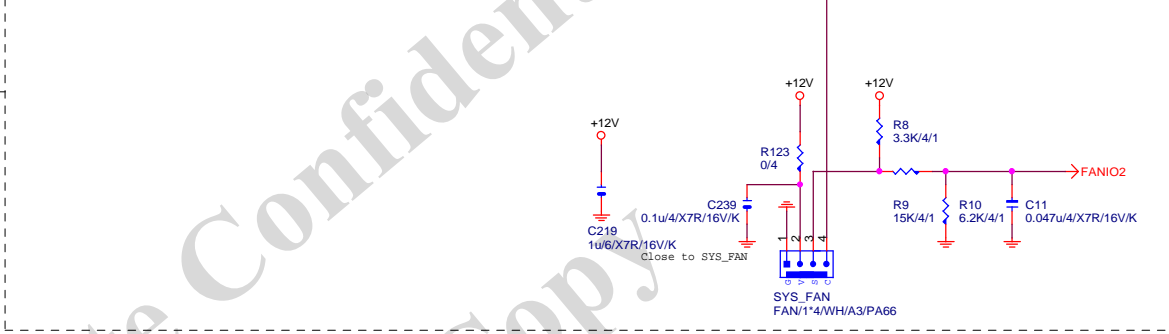

Gigabyte Confidential  
Do not Copy

<b>Gigabyte Technology</b>		
Title		
HWM,FAN CTRL,OV		
Size	Document Number	Rev
Custom	<b>GA-H61M-DS2</b>	<b>4.01</b>
Date:	Wednesday, September 25, 2013	Sheet 18 of 30

# DUAL BIOS

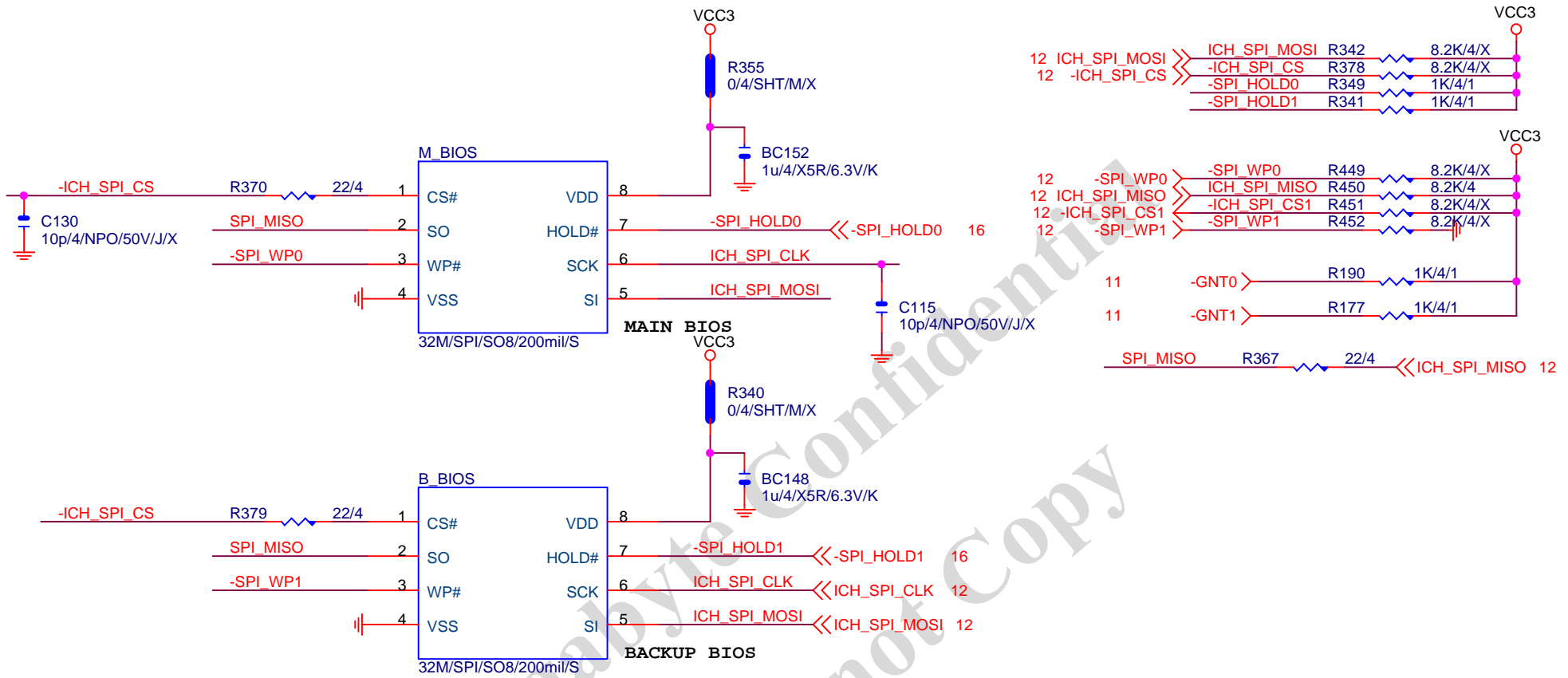

BOOT DEVICE	GNT1	GNT0
LPC	0	0
PCI	0	1
SPI	1	1

1 means floating  
0 means PD 1K

**Gigabyte Technology**

**SINGLE BIOS**

Size A | Document Number **GA-H61M-DS2** | Rev **4.01**

Date: Wednesday, September 25, 2013 | Sheet 19 of 30

**FRONT USB1**

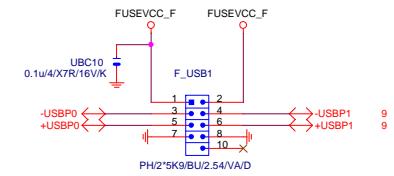

change to BLUE COLOR

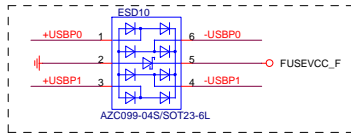

Close to connector

**SATA LED**



**CLOSE F\_USB1**

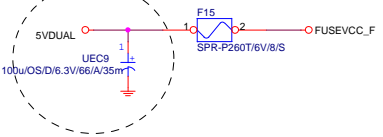

**FRONT USB2**

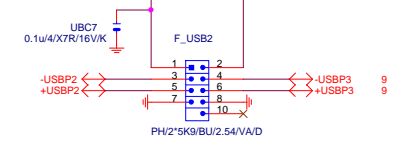

Close to connector

**FRONT USB3**

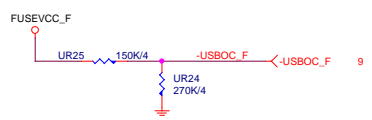
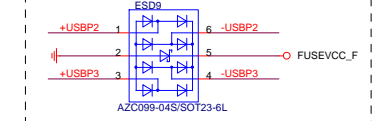

**SPKR**

RESETCONIN DEFAULT LOW  
4sec, 會發BEEP, 故改2N7002

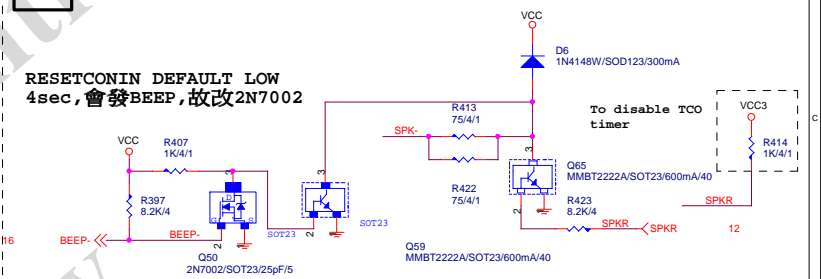

**INTEL FRONT PANEL**

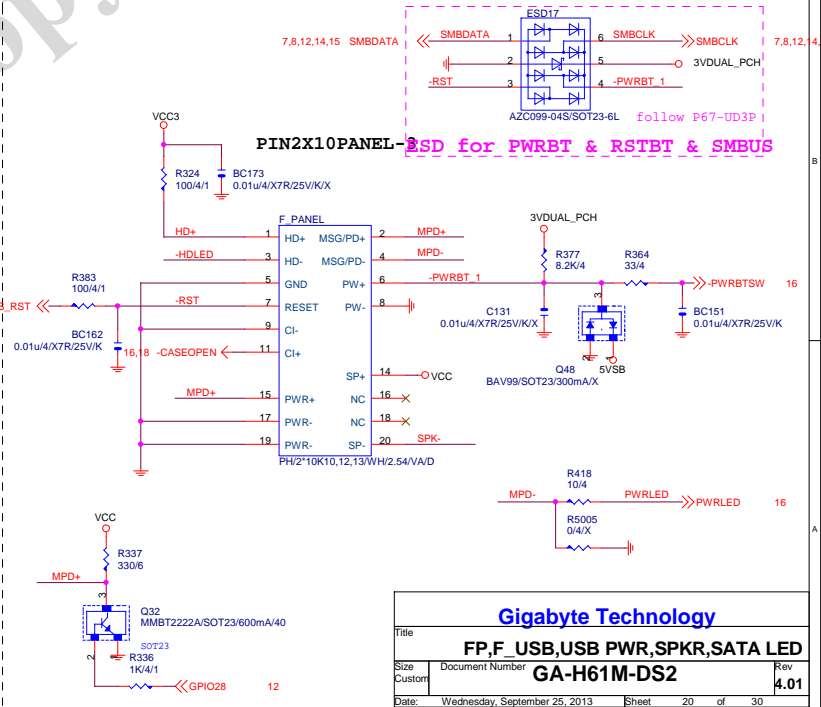

<b>Gigabyte Technology</b>			
Title	<b>FP,F_USB,USB PWR,SPKR,SATA LED</b>		
Size	Document Number	<b>GA-H61M-DS2</b>	
Date:	Wednesday, September 25, 2013	Sheet	20 of 30
			Rev <b>4.01</b>

	ALC883	ALC888-VA	ALC888B	ALC888-VD	ALC892R	ALC889	ALC889A
CR46	X	X	X	X	X	X	O
CR57	X	X	X	X	X	X	O
CR49	O	O	X	X	X	O	O
CBC40	X	X	X	10uF/X5R	10uF/X5R	X	X
CR20	O	X	X	X	X	X	X
CR26	20K/1%	20K/1%	20K/1%	20K/1%	20K/1%	20K/1%	20K/0.1%
CR47	X	X	O	X	O	O	X
CR48	O	O	X	O	X	X	O
CBC2/CBC4/CBC5/CBC6/CBC10/CBC11	4.7uF/X5R	4.7uF/X5R	4.7uF/X5R	4.7uF/X5R	4.7uF/X5R	10uF/X5R	4.7uF/X5R
CR1/CR3/CR10/CR12/CR15/CR19/CR56/CR27/CR55/CR37/CR28/CR34/CR6/CR9/CR51/CR61	75 ohm	75 ohm	75 ohm	75 ohm	75 ohm	66 ohm or lower	75 ohm
CR66/CR68/CD3/CBC41	X	X	X	O	X	X	X
CR67/CD1/CD2/CQ3/CQ5	O	O	O	X	O	O	O

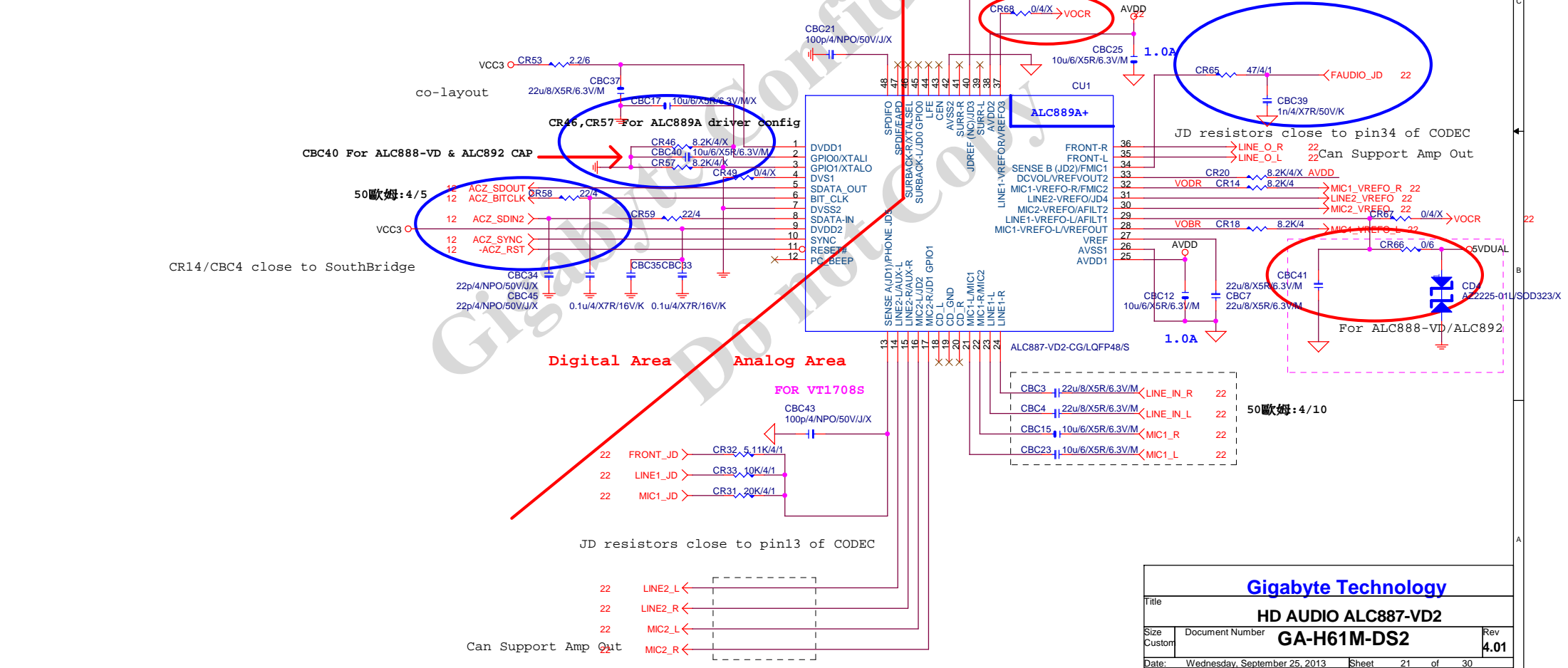

**Gigabyte Technology**

**HD AUDIO ALC887-VD2**

Size: Document Number **GA-H61M-DS2** Rev **4.01**

Date: Wednesday, September 25, 2013 Sheet 21 of 30

**CODEC POWER/EMI PAD**

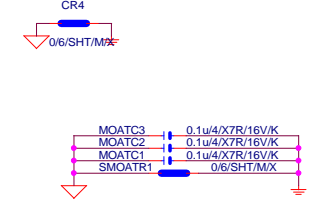
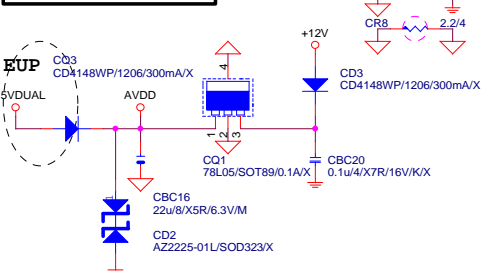

**AZALIA JACK**

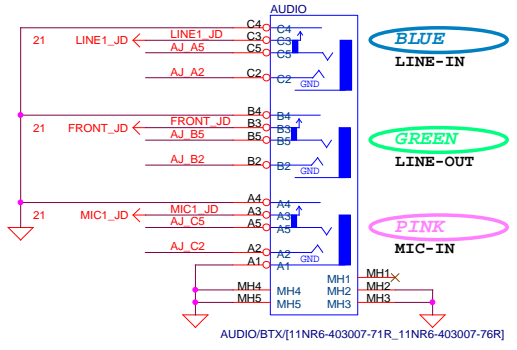
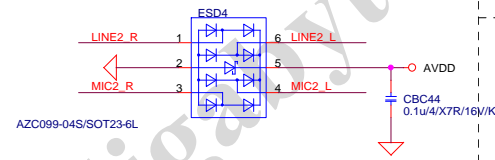

**LINE-OUT**

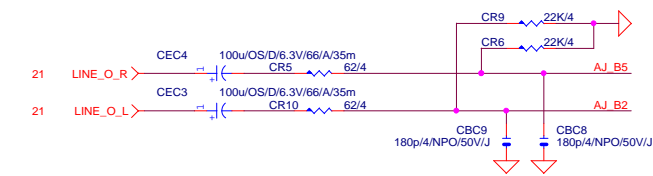

**LINE-IN**

Verify MIC function in LINE-in

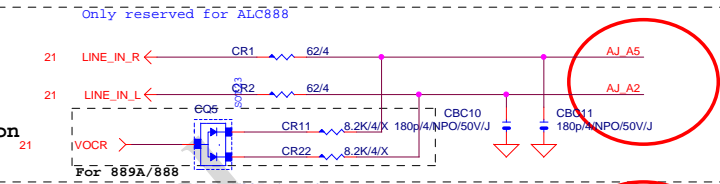

**MIC-IN**

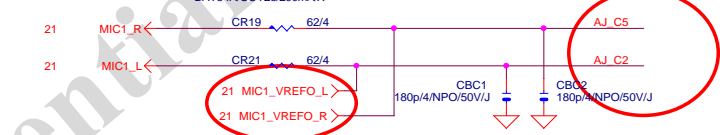

**AZALIA FRONT PANEL**

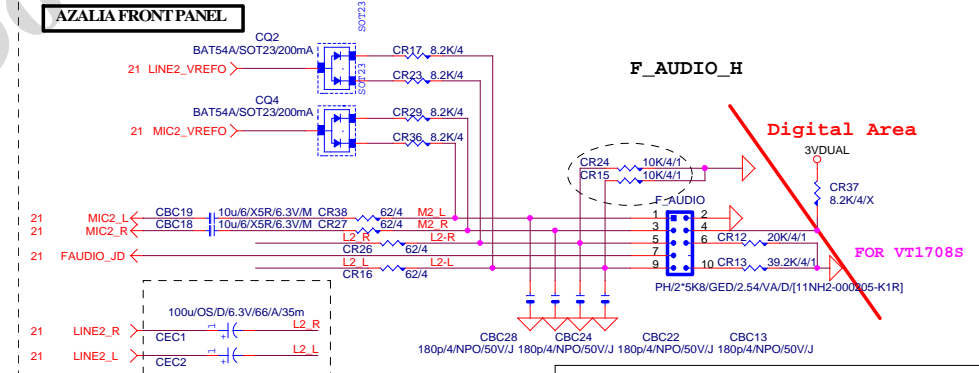

<b>Gigabyte Technology</b>			
<b>AUDIO JACK</b>			
Title	<b>AUDIO JACK</b>		Rev
Size Custom	Document Number	<b>GA-H61M-DS2</b>	4.01
Date:	Wednesday, September 25, 2013	Sheet	22 of 30







**ATXX24 POWER CONNECTOR**

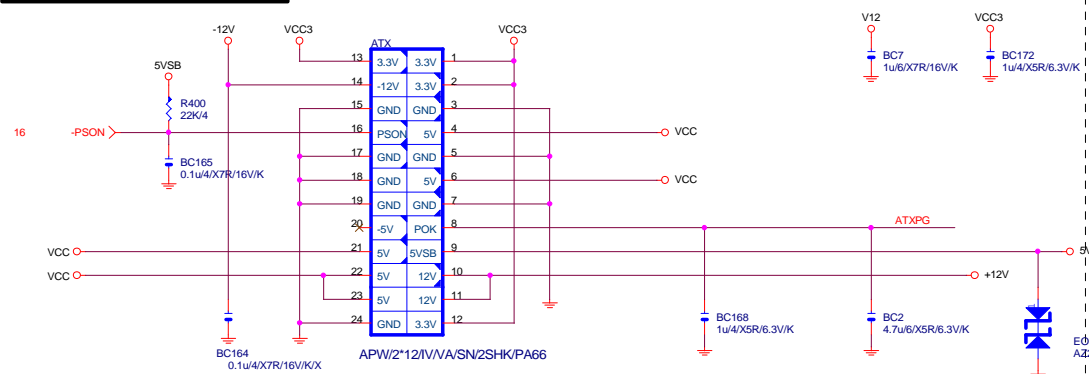

**ATXX4 POWER CONNECTOR**

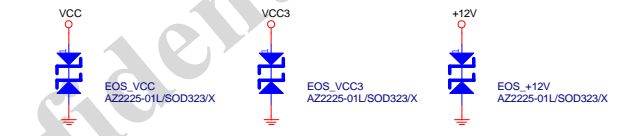
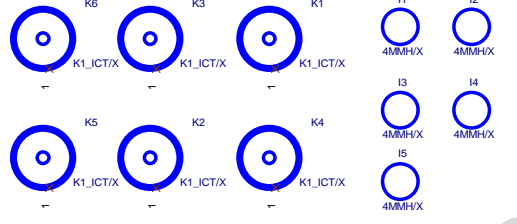
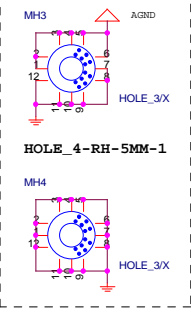
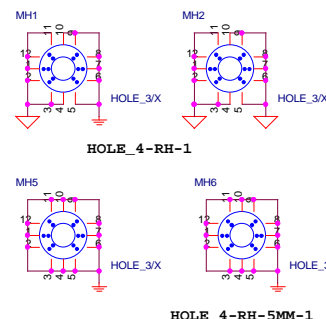
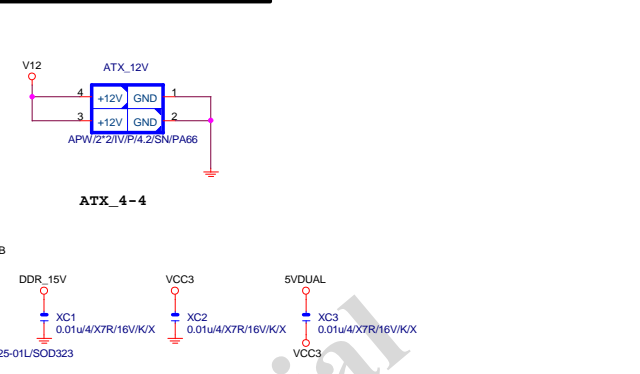

To prevent the 5VSB under loading when boot

5VDUAL1 (USB PORT/DDR.III POWER)  
5VDUAL ( 3VDUAL/OTHER)

-S\_WARN-->5VDUAL1-->-S\_ACK (PCH)-->-DEPSLP/-RSMRST-->5VDUAL-->3VDUAL

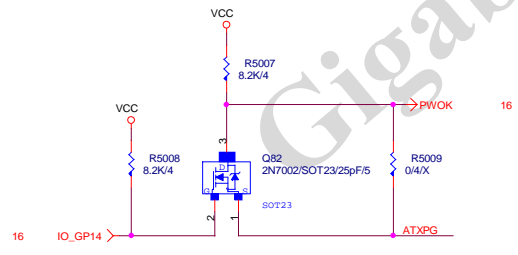

**【技術通報R&D技術通報153】**

To fix 12V light load abnormal issue

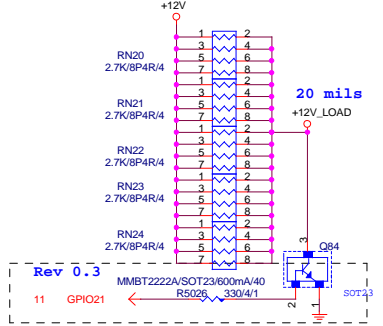

Rev 0.3

VTT_EN	
HI	ENABLE
LO	DISABLE

VTT OV option



VCCSA

PDG 0.8

VSA_SEL	
HI	0.85V
LO	0.925V

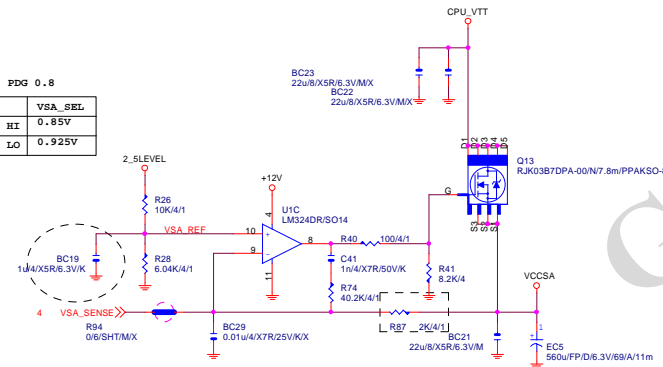

VCCSA PWR SEQ

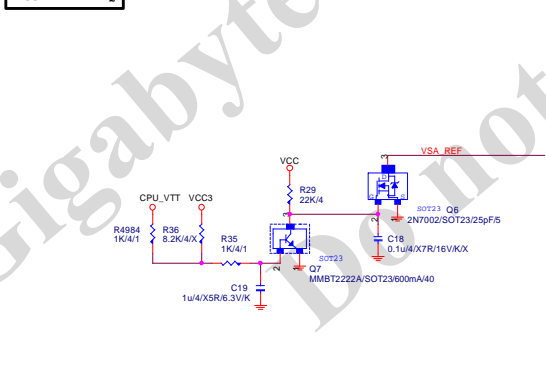

CPU\_VTT PWR SEQ

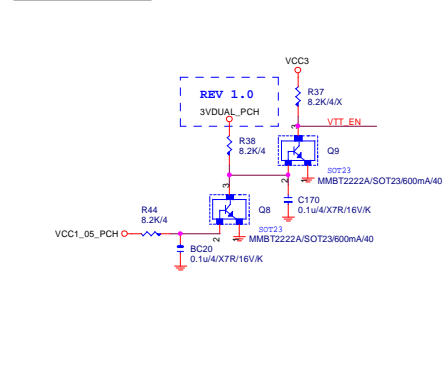

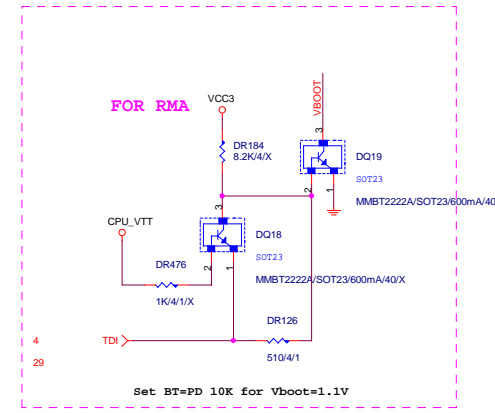
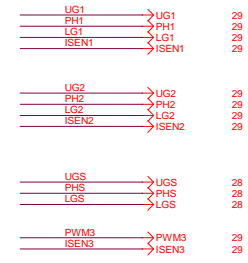
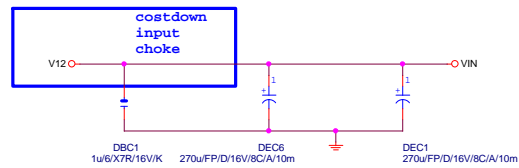
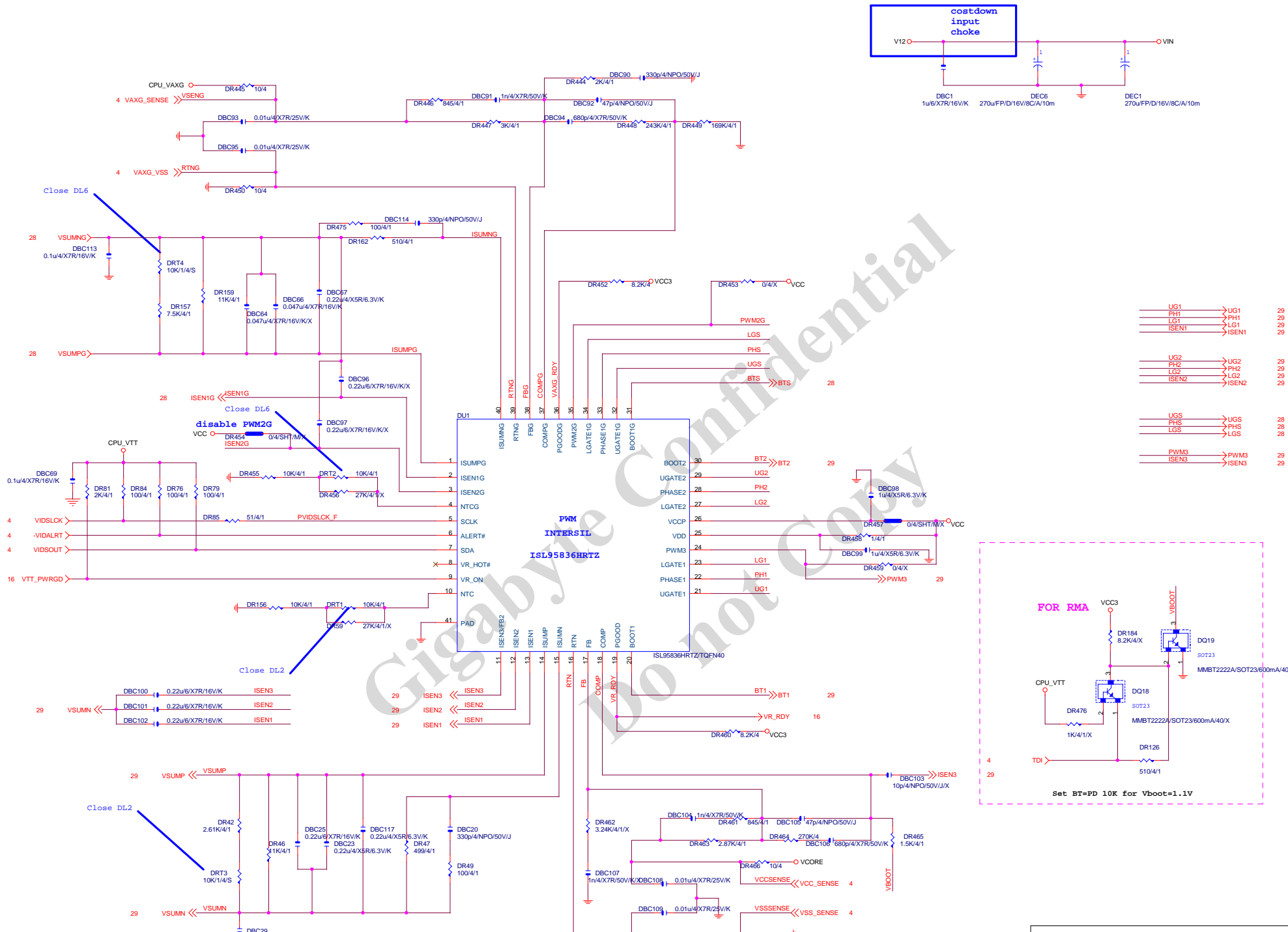

**BOTTOM PAD  
CONNECT TO  
GND  
THROUGH 10  
VIA**

<b>Gigabyte Technology</b>		
Title	CPU CORE VR-1	
Size	Document Number	Rev
Custom	<b>GA-H61M-DS2</b>	<b>4.01</b>
Date:	Wednesday, September 25, 2013	Sheet 27 of 30

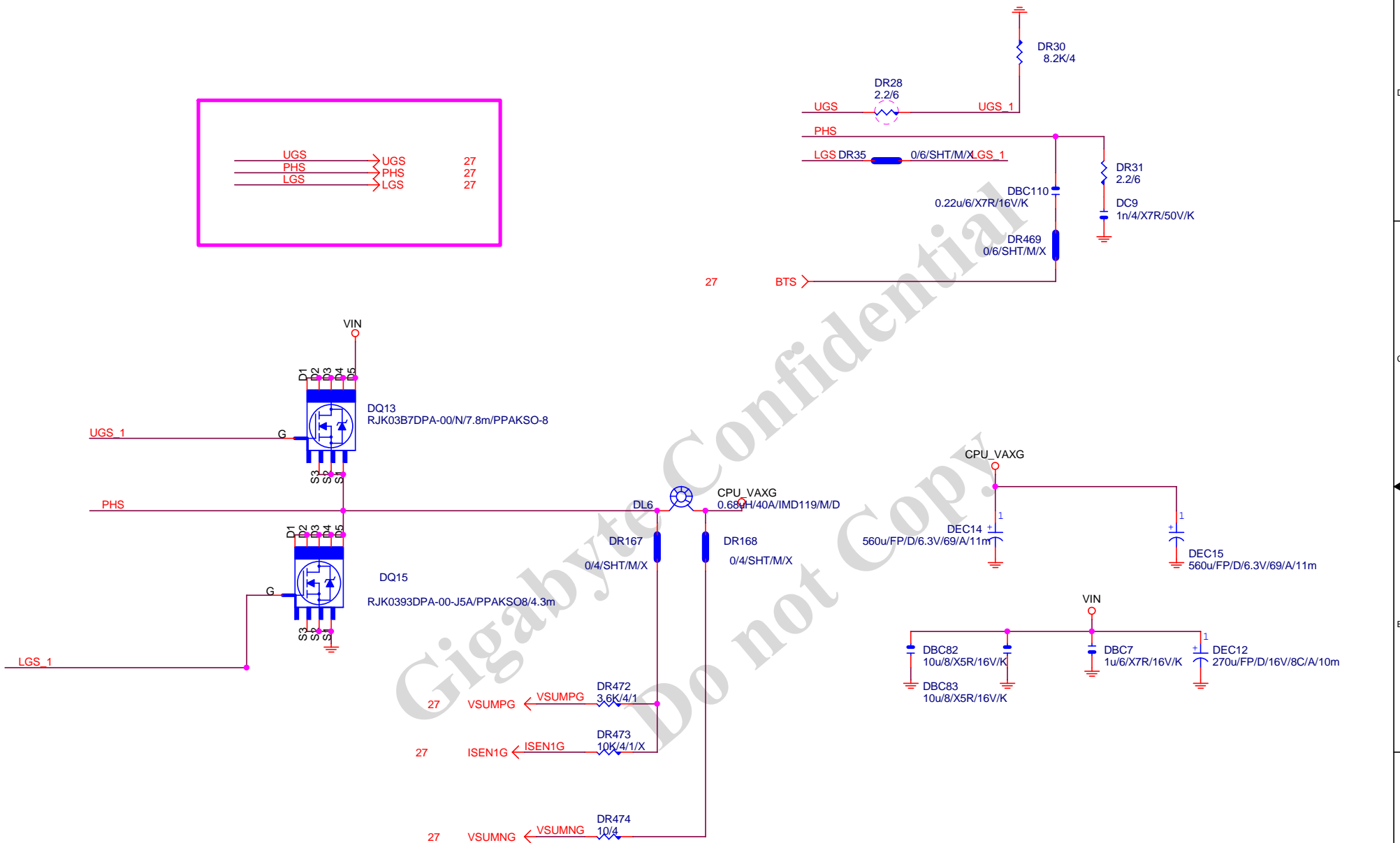
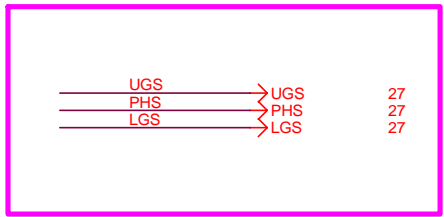

<b>Gigabyte Technology</b>		
Title <b>CPU CORE VR-2</b>		
Size Custom	Document Number <b>GA-H61M-DS2</b>	Rev <b>4.01</b>
Date:	Wednesday, September 25, 2013	Sheet 28 of 30

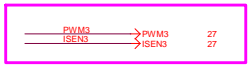
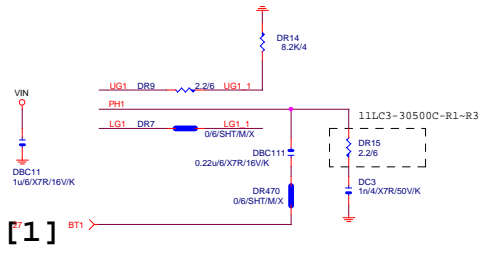
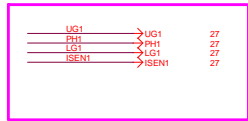

Pop 1S16625CB for PB1  
[1S16625CBZ/908]

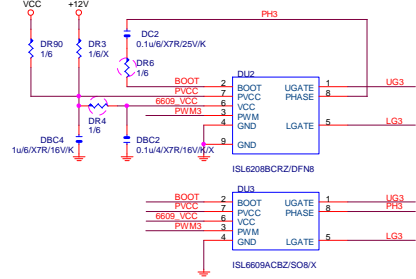

6609 colay with 6208

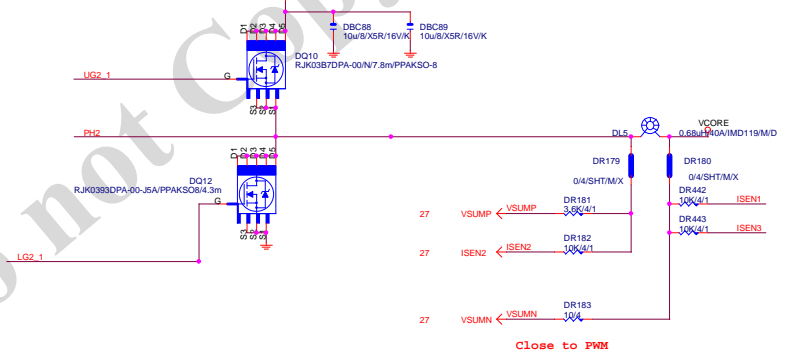
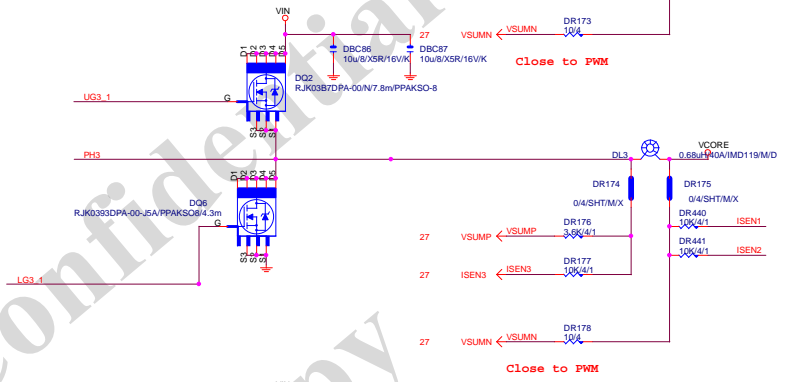
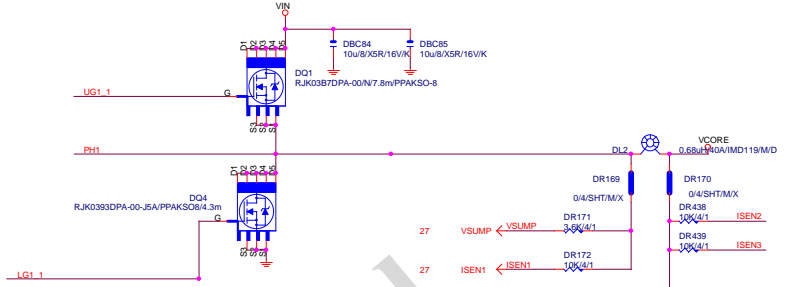
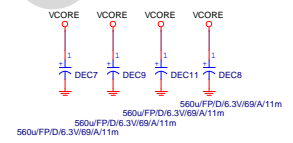
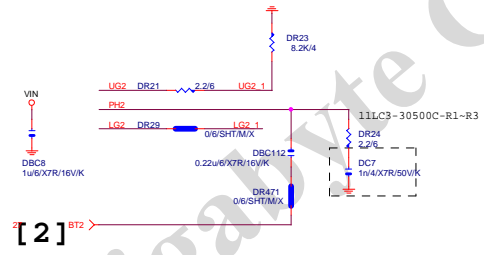
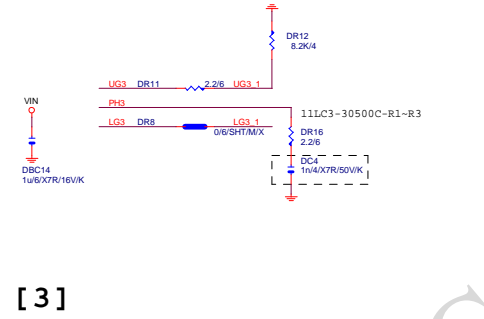



**LPT PORT**

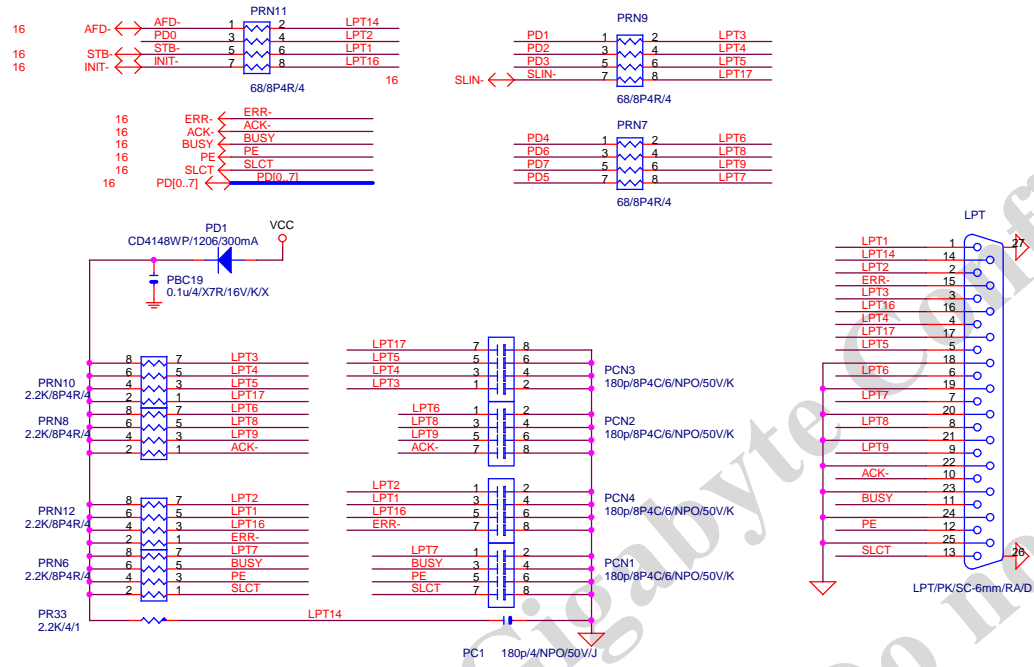

<b>Gigabyte Technology</b>			
Title			
<b>LPT</b>			
Size	Document Number		Rev
Custom	<b>GA-H61M-DS2</b>		<b>4.01</b>
Date:	Wednesday, September 25, 2013	Sheet	30 of 30