

Model Name: GA-H110M-S2V

rev:1.0

| SHEET | TITLE |
|-------|----------------------------|
| 01 | COVER SHEET |
| 02 | BOM & PCB MODIFY HISTORY |
| 03 | BLOCK DIAGRAM |
| 04 | CPU_LGA1151-A |
| 05 | CPU_LGA1151-B-DDR4 |
| 06 | CPU_LGA1151-C |
| 07 | CPU_LGA1150-D |
| 08 | DDR4 CHANNEL A |
| 09 | DDR4 CHANNEL B |
| 10 | PCH_CLK BUFFER |
| 11 | PCH_DMI,USB,PCIE |
| 12 | PCH_MISC |
| 13 | PCH SATA,PCIE,SATA_EXPRESS |
| 14 | PCH_PWR,GND |
| 15 | Dual BIOS |
| 16 | ITE 8628 LPC IO |
| 17 | HWM |
| 18 | FAN CTRL--SIO |
| 19 | PCI EXPRESS*16 SLOT |
| 20 | PCI EXPRESS*1 SLOT |
| 21 | SATA |
| 22 | ISL95858_856 PWM |
| 23 | ISL95858_856 MOS_VCORE |
| 24 | ISL95858_856 MOS_VCCGT |
| 25 | VCCSA_VCCIO_VCCPLL |
| 26 | RT8237_DDR_VDDQ |
| 27 | RT8068_VPP |

| SHEET | TITLE |
|-------|------------------------------|
| 28 | RT8237_PCH_VCC1_0_PCH |
| 29 | DISCRETE POWER |
| 30 | ATX POWER , A_-PROCHOT |
| 31 | KB_MS_USB |
| 32 | RTD2168 - DP to VGA - IC |
| 33 | RTD2168 - DP to VGA - Conn |
| 34 | R_USB30 |
| 35 | REALTEK - RTL8111G |
| 36 | USB20_LAN CONNECTOR-RTL8111G |
| 37 | Realtek ALC887 |
| 38 | REAR AUDIO JACK |
| 39 | F_USB30 |
| 40 | F_USB20 |
| 41 | COM , LPT , TPM |
| 42 | F_PANEL |
| 43 | HDMI |
| 44 | EMI/ESD |
| 45 | POWER MAP |
| 46 | TABLE LIST |
| 47 | NTC MAP |
| 48 | |
| 49 | |
| 50 | |
| 51 | |

Model Name: GA-H110M-S2V

rev:1.0

Circuit or PCB layout change

Component value change history

2015/12/22

| Data | Change Item | Reason |
|------------|---------------|-----------------|
| 2016/01/28 | first release | 9MH11MSV-00-10A |
| | | |
| | | |
| | | |
| | | |
| | | |
| | | |
| | | |
| | | |
| | | |
| | | |
| | | |
| | | |
| | | |
| | | |
| | | |
| | | |
| | | |
| | | |
| | | |
| | | |
| | | |
| | | |
| | | |
| | | |
| | | |
| | | |
| | | |
| | | |
| | | |
| | | |
| | | |
| | | |
| | | |
| | | |
| | | |

| DATE | Change Item | Reason |
|------------|--|------------------|
| 2015/12/22 | 由GA-H110M-S2V DDR3 rev1.01 修改 1、DDR3 change to DDR4 2、Add VPP Power | 9MH11MSV3-00-10B |
| | | |
| | | |
| | | |
| | | |
| | | |
| | | |
| | | |
| | | |
| | | |
| | | |
| | | |
| | | |
| | | |
| | | |
| | | |
| | | |
| | | |
| | | |
| | | |
| | | |
| | | |
| | | |
| | | |
| | | |
| | | |
| | | |
| | | |
| | | |
| | | |
| | | |
| | | |
| | | |
| | | |



| | | |
|--------------------------|---------------------------|---------------|
| Title | | |
| BOM & PCB MODIFY HISTORY | | |
| Size | Document Number | Rev |
| Custom | GA-H110M-S2V | 1.0 |
| Date: | Wednesday, March 09, 2016 | Sheet 2 of 47 |

BLOCK DIAGRAM

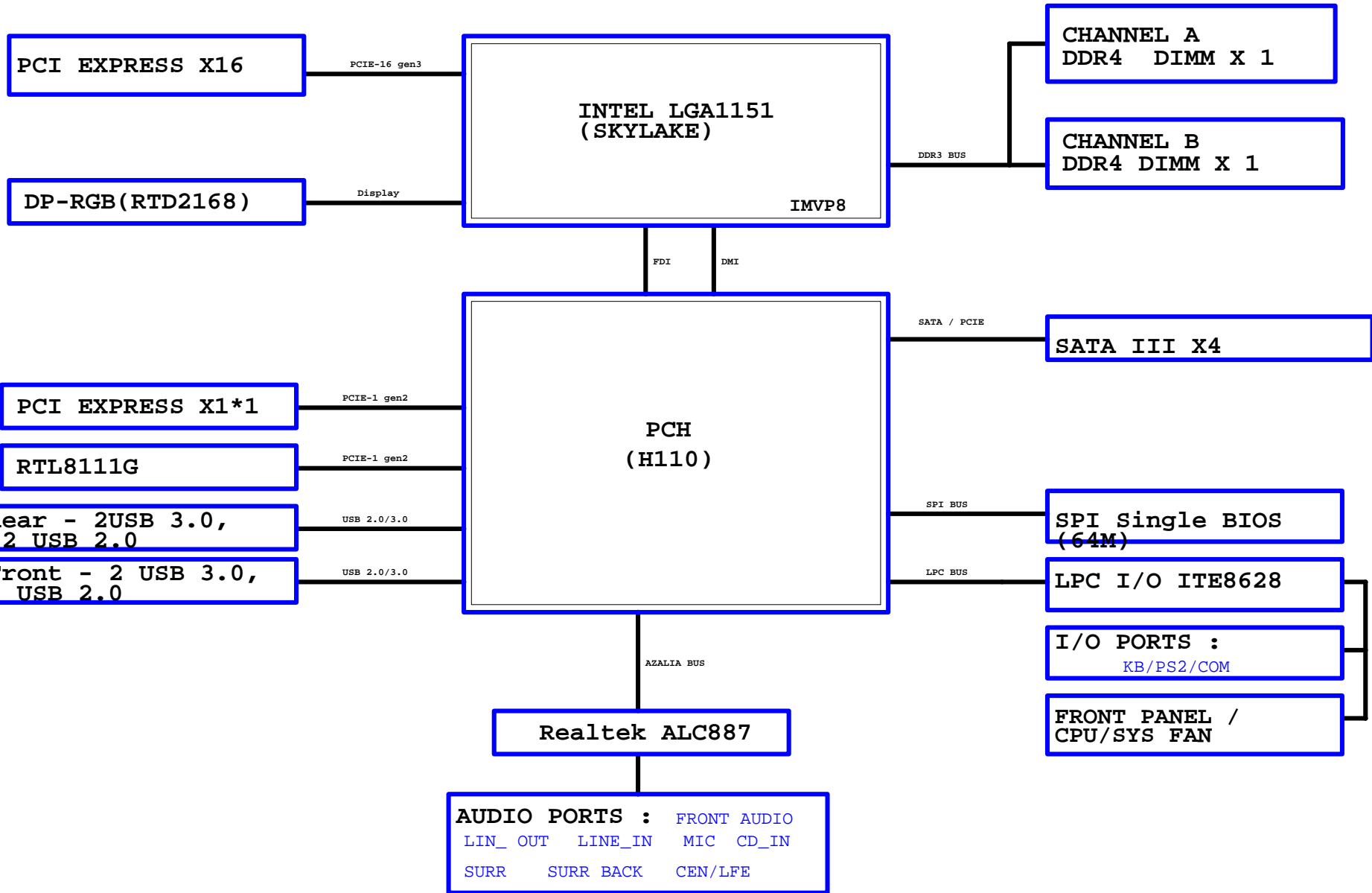

*** Rev0.2B**

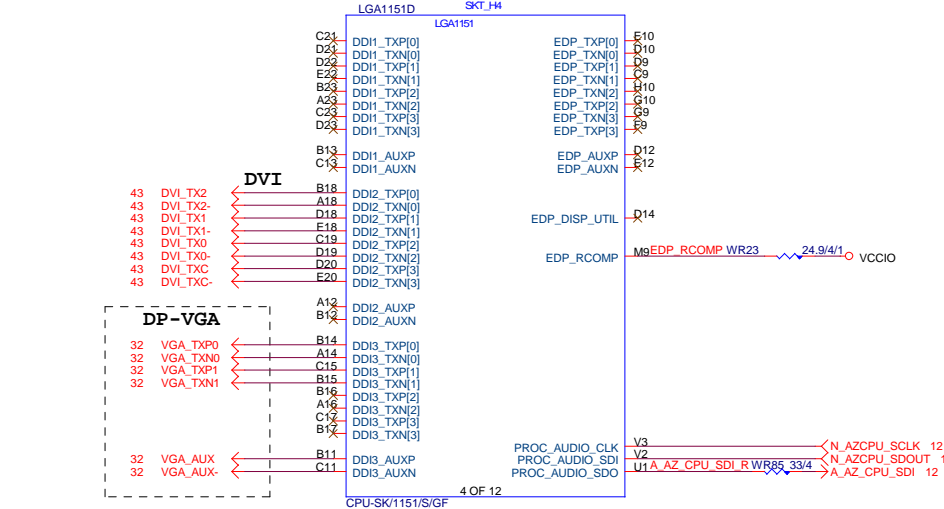
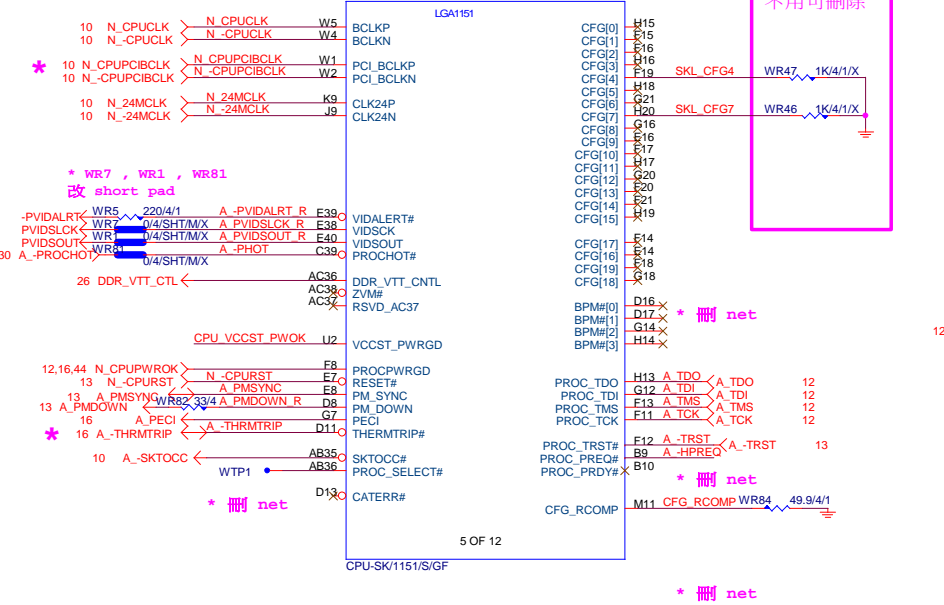

G-15u : (CPU-SK/1151/S/15)
 10SC1-F01151-11R / 10SC1-F01151-12R
 G-FL : (CPU-SK/1151/S/GF)
 10SC1-F01151-21R / 10SC1-F01151-22R

4 layer HDMI/DP/eDP/=====4/4/4//15
 6 layer HDMI/DP/eDP/=====4/5.5/4//15
 Impedance=85 +- 15%

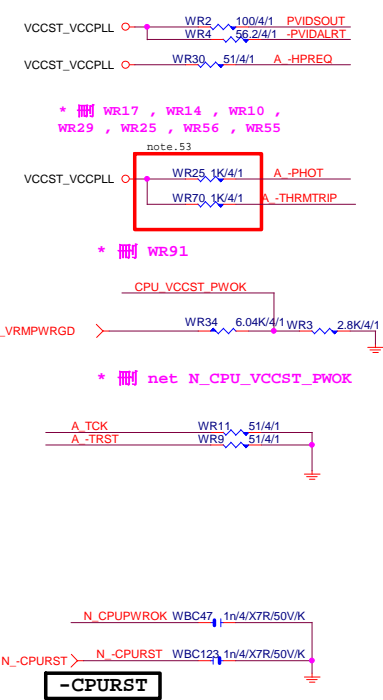

CFG[2]:x16 Lane Numbering
 Reversal. 1=
 NORMAL;0=reversal
 CFG[4]: eDP
 enable:1:disable/0=enable
 CFG[6:5]:PCI Express* Bifurcation; 11=
 1 x16 PCI Express;10=2x8 PCI Express
 CFG[7]: PEG Training;1=(default) PEG Train
 immediately following RESET#;0=PEG Wait
 for BIOS

| Bifurcation Config. | Signals | Lanes |
|---------------------|---------|---------------|
| | CFG[6] | CFG[5] CFG[2] |
| 1x16 | 1 | 1 1 |
| 1x16 Reversed | 1 | 1 0 |
| 2x8 | 1 | 0 1 |
| 2x8 Reversed | 1 | 0 0 |
| 1x8+2x4 | 0 | 0 1 |
| 1x8+2x4 Reversed | 0 | 0 0 |

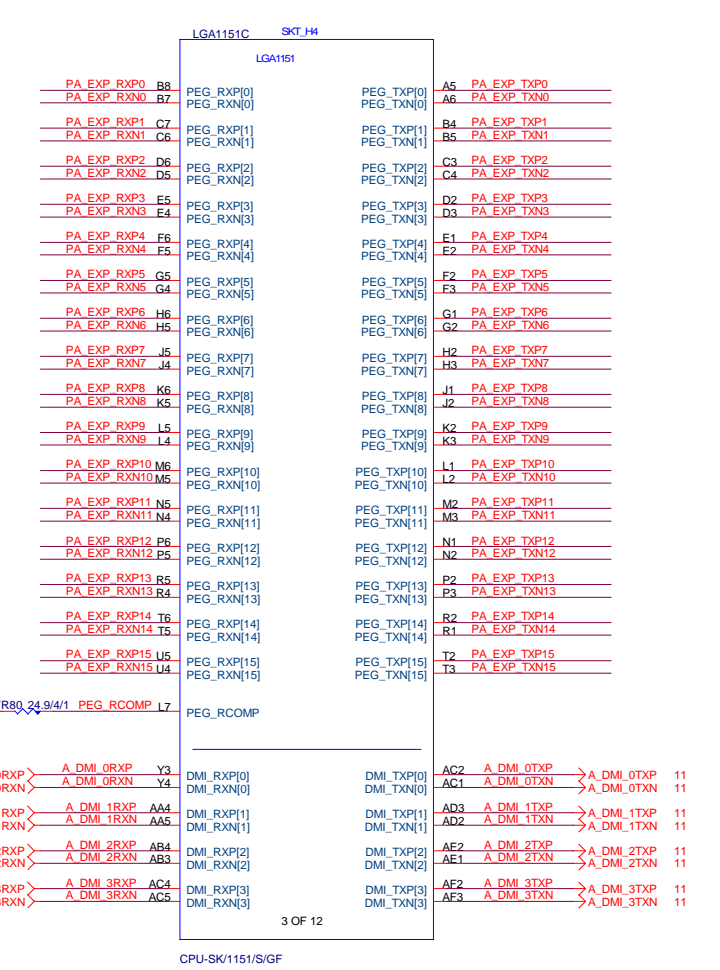

PA EXP TXP[0..15] >>> PA_EXP_TXP[0..15] 19
 PA EXP TXN[0..15] >>> PA_EXP_TXN[0..15] 19
 PA EXP RXP[0..15] >>> PA_EXP_RXP[0..15] 19
 PA EXP RXN[0..15] >>> PA_EXP_RXN[0..15] 19

4 layer PEG/DMI/=====4/4/4//15
 6 layer PEG/DMI/=====4/5.5/4//15

Impedance=85 +- 15%
 W=12 mil out of CPU
 S=15 mil out of CPU

Gigabyte Technology

CPU LGA1151-A

| | | |
|---------------------------------|--|-------------------|
| Size Custom | Document Number GA-H110M-S2V | Rev 1.0 |
| Date: Wednesday, March 09, 2016 | Sheet 4 | of 47 |

* 改DDR4 net

LGA1151A SKT_H4

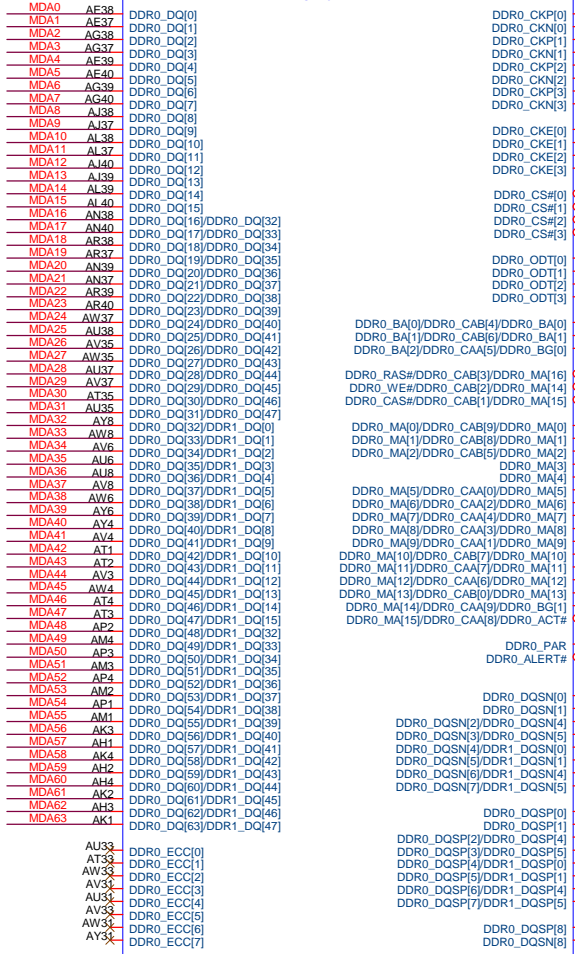

DDR CHANNEL A
1 OF 12
CPU-SK1151/S/GF

BLACK NI

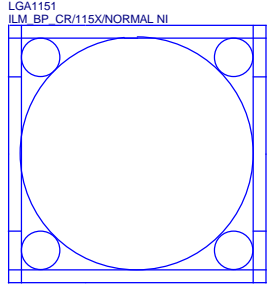

Need check the new CPU ME

LGA1151B SKT_H4

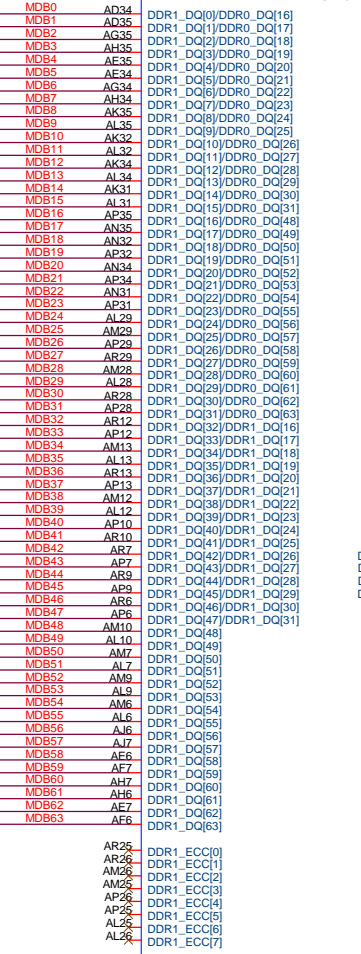

DDR CHANNEL B
2 OF 12
CPU-SK1151/S/GF

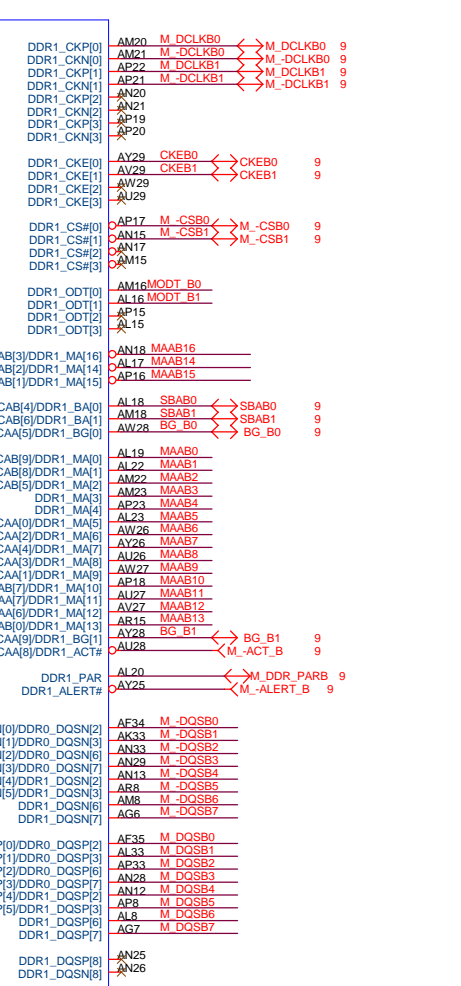

DDR CHANNEL B
2 OF 12
CPU-SK1151/S/GF

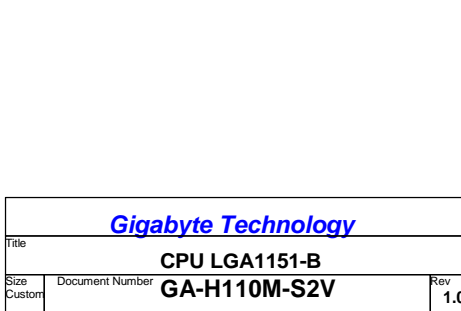
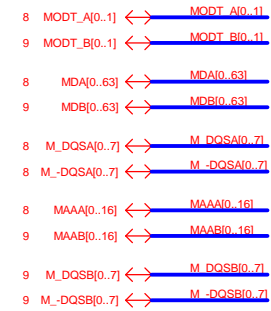

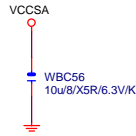

* 刪 WBC124, WBC125, WBC126, WBC127 電容

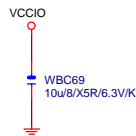

* 刪 VCCGT 電容

* 刪 WBC50 電容
*_WBC51, WBC52
VDDQ 改 VCCSA

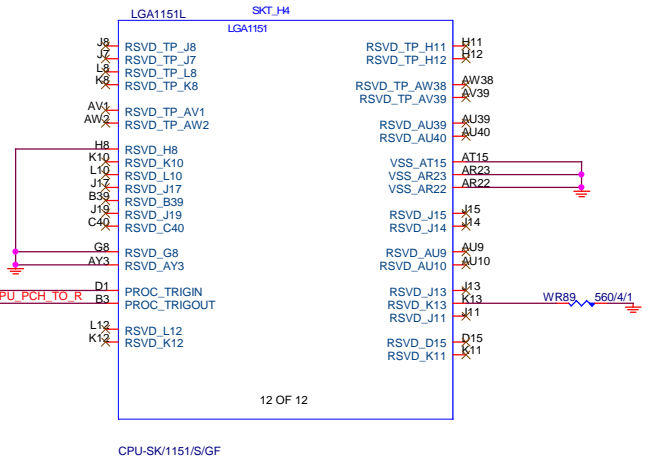
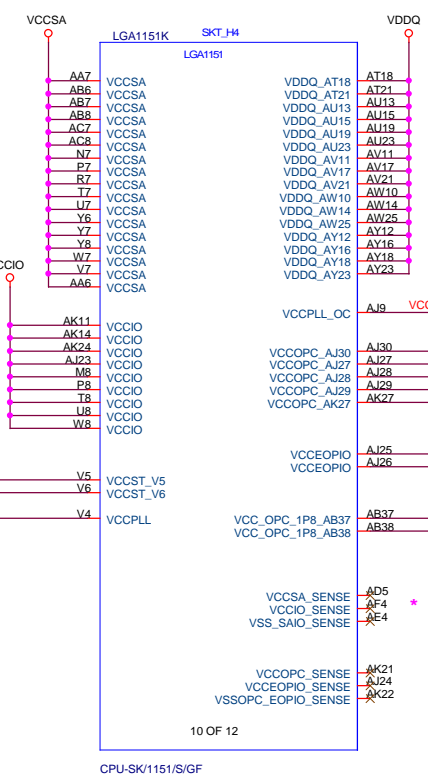
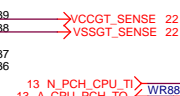
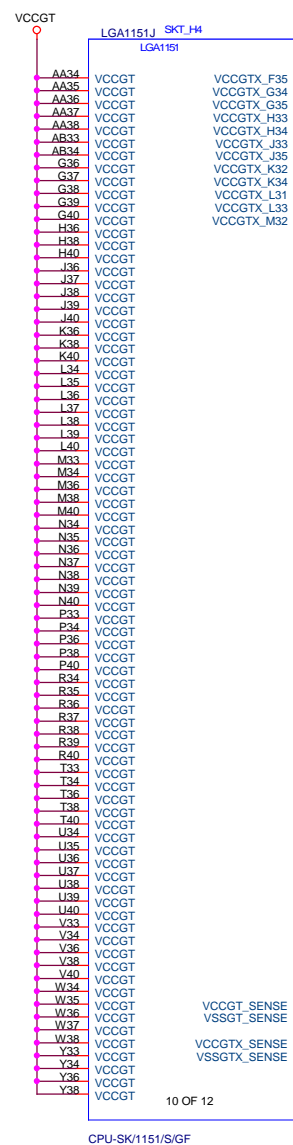
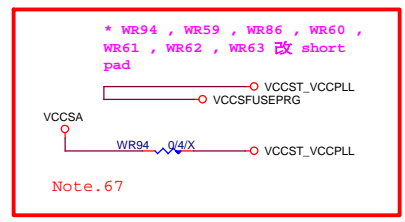

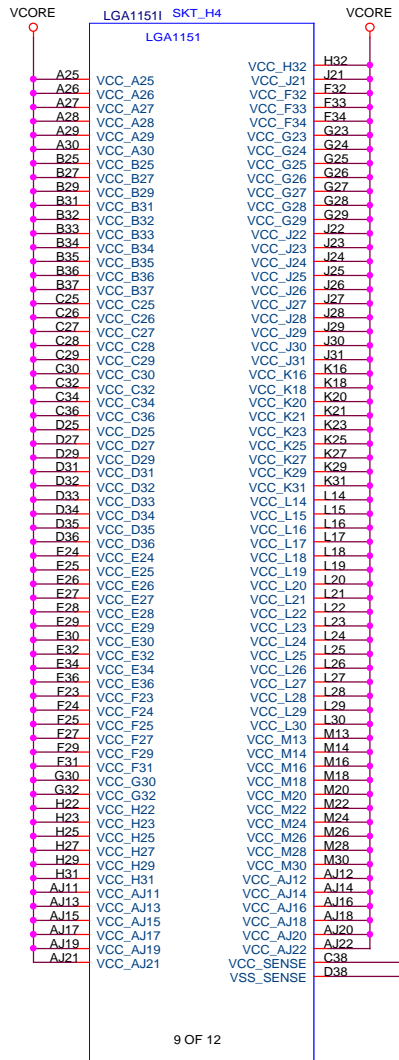

9 OF 12

CPU-SK/1151/S/GF

* 刪 Vcore 電容

VCORE_VCC_SEN 22
VCORE_VSS_SEN 22

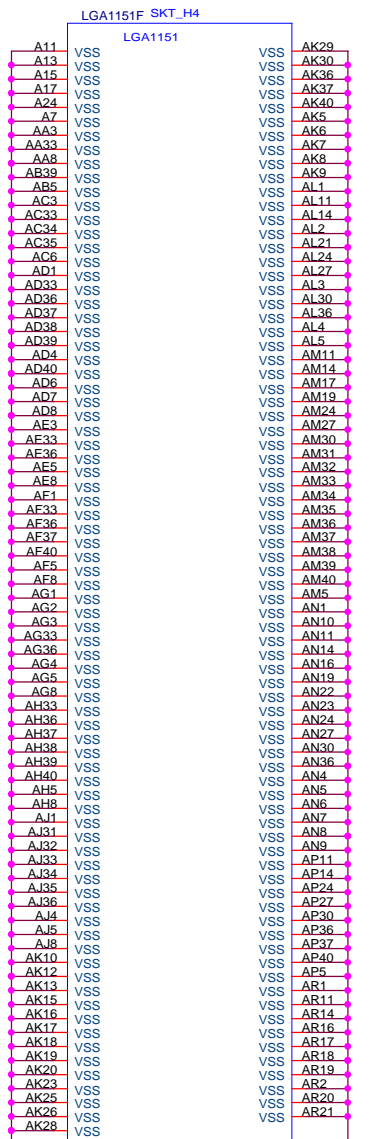

6 OF 12

CPU-SK/1151/S/GF

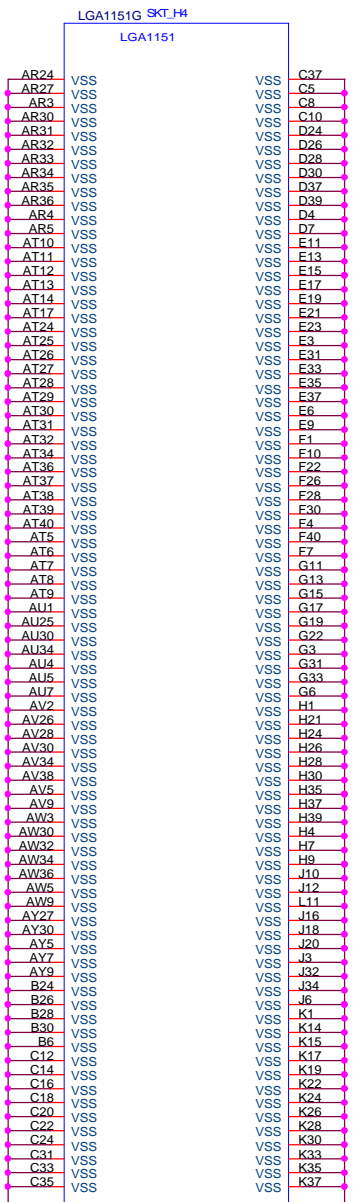

7 OF 12

CPU-SK/1151/S/GF

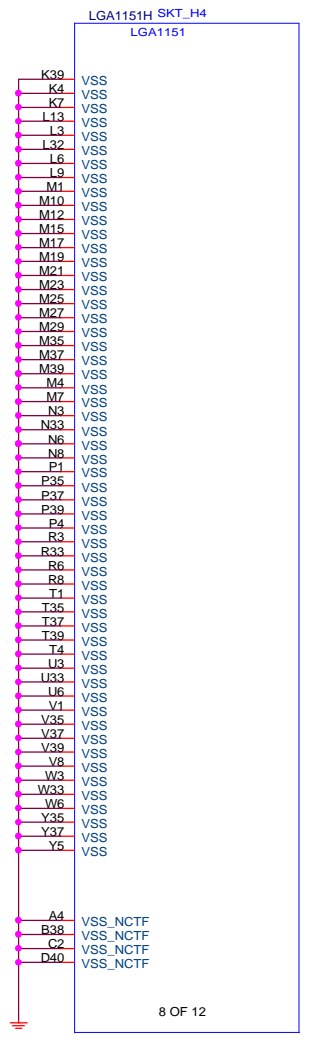

8 OF 12

CPU-SK/1151/S/GF

A4 VSS_NCTF
B38 VSS_NCTF
C2 VSS_NCTF
D40 VSS_NCTF

| | | |
|---------------------------------|--|-------------------|
| Gigabyte Technology | | |
| Title CPU LGA1151-C | | |
| Size Custom | Document Number GA-H110M-S2V | Rev 1.0 |
| Date: Wednesday, March 09, 2016 | Sheet 7 of 47 | |

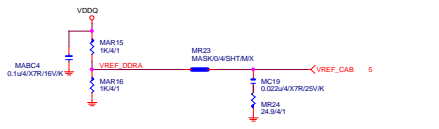
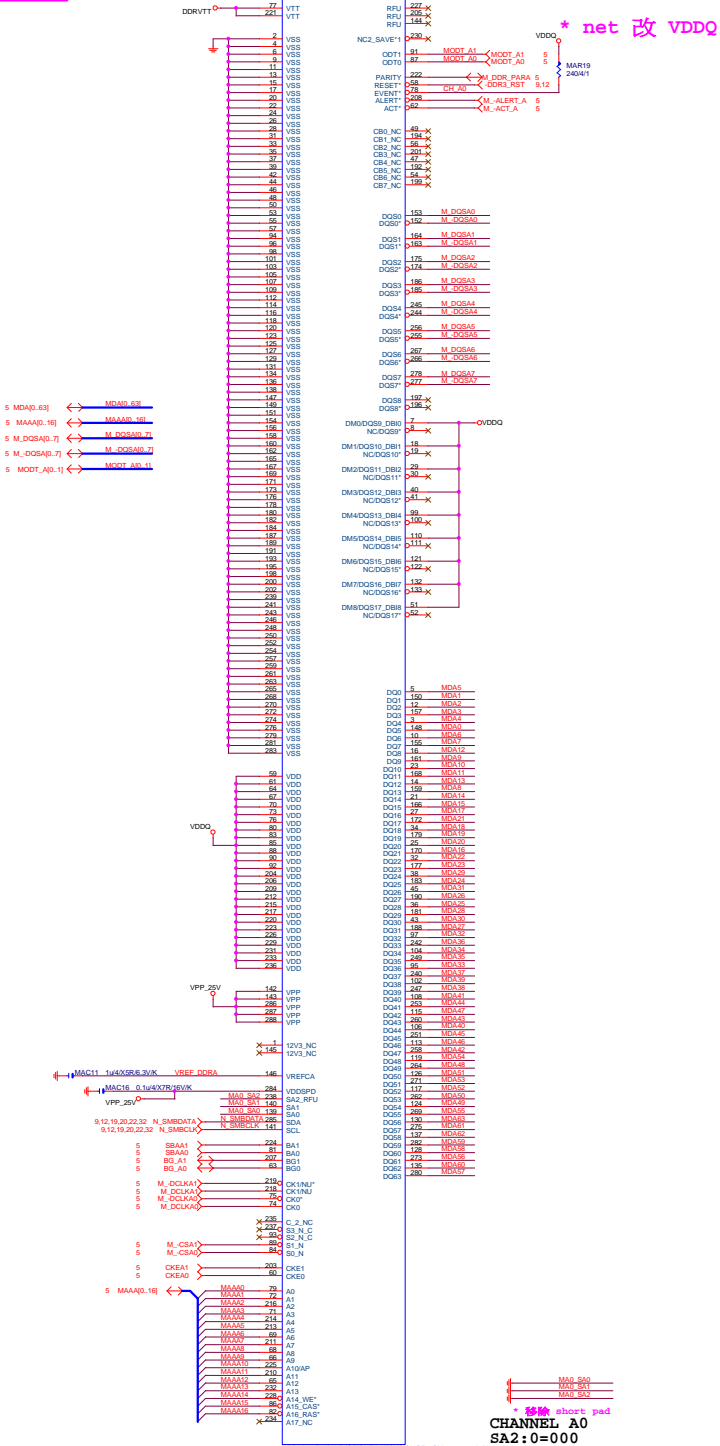

DDR12V Decouple

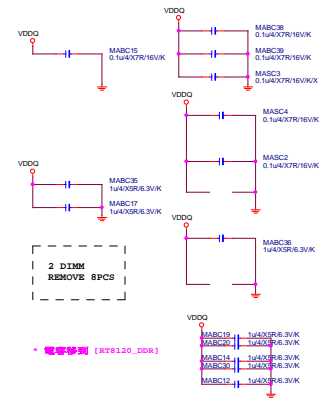

DDRVTT Decouple

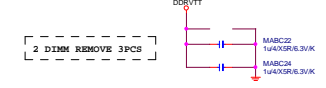

* 新電容

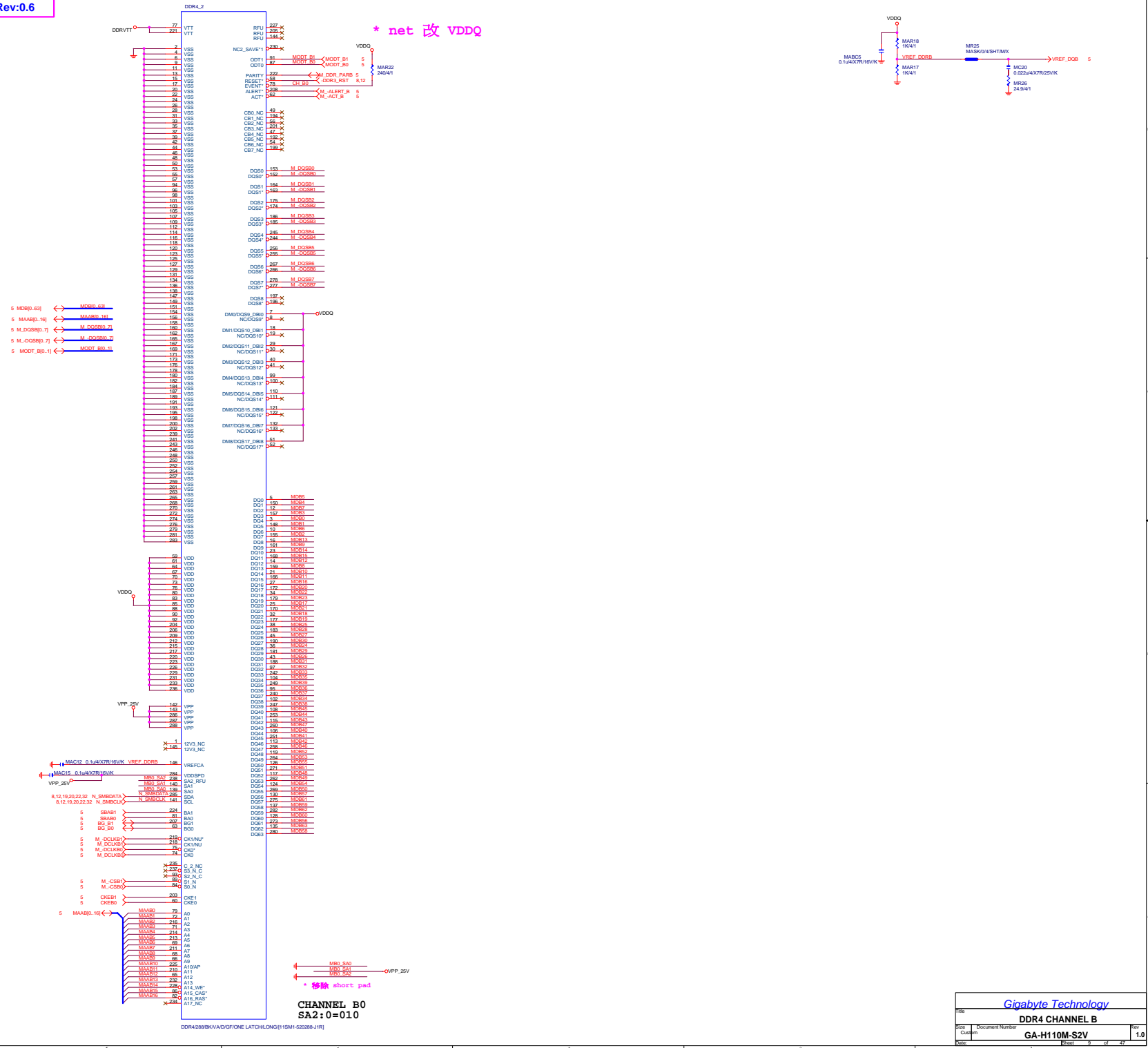

Gigabyte Technology

File: **DDR4 CHANNEL B**

Size: **GA-H110M-S2V**

Date: **1.0**

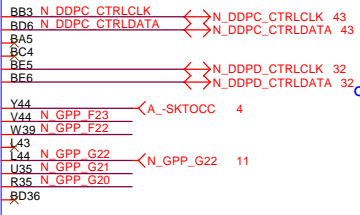
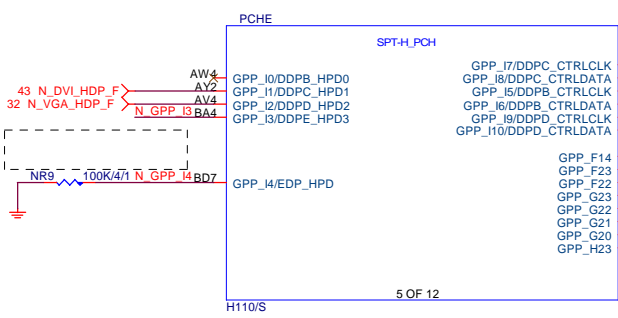

CLK: 4/15 < 1000; Guard GND

32.768KHZ

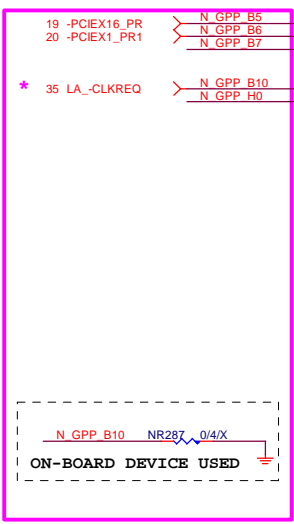
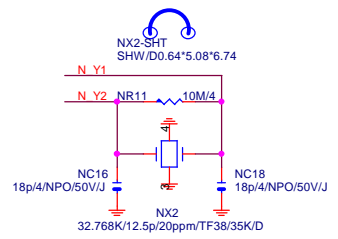

ON-BOARD DEVICE USED

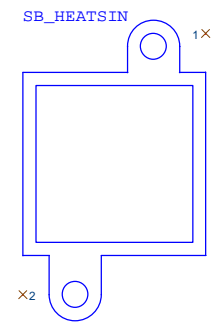
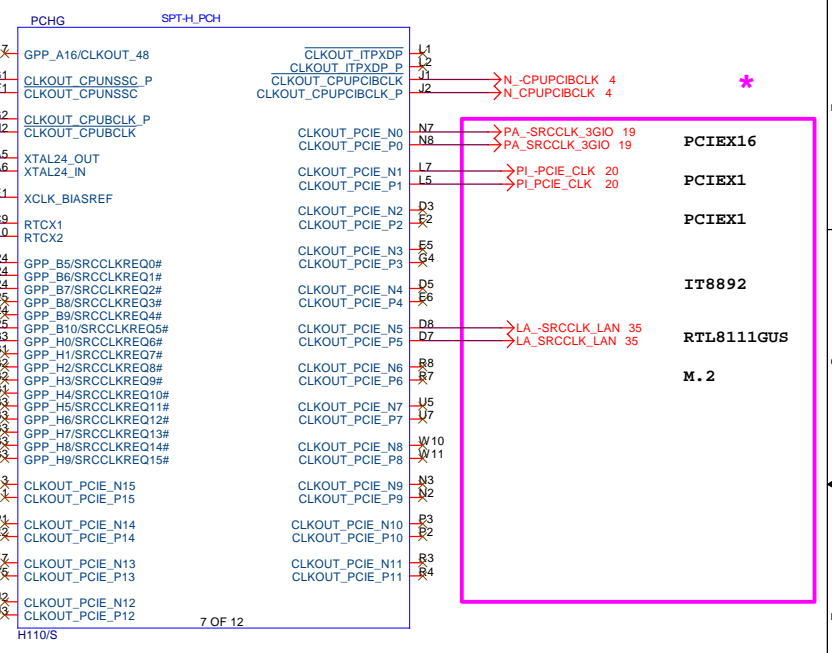

LOW COST ICH7 HEATSINK
BLACK HS
PCH_HS [12SP2-030005-51R_12SP2-030005-52R_12SP2-030005-53R]
BGHSINK-Z1704M-HD3 LOW COST

| | | | |
|-------------------------|---------------------------|----------------------------|----------|
| ANS 4353298 | | Gigabyte Technology | |
| Title | | | |
| PCH CLOCK BUFFER | | | |
| Size | Document Number | Rev | |
| Custom | GA-H110M-S2V | 1.0 | |
| Date: | Wednesday, March 09, 2016 | Sheet | 10 of 47 |

CLK: 4/15 < 1000 mils±100 mils; Guard GND

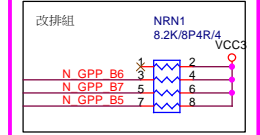
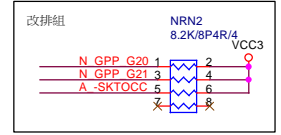

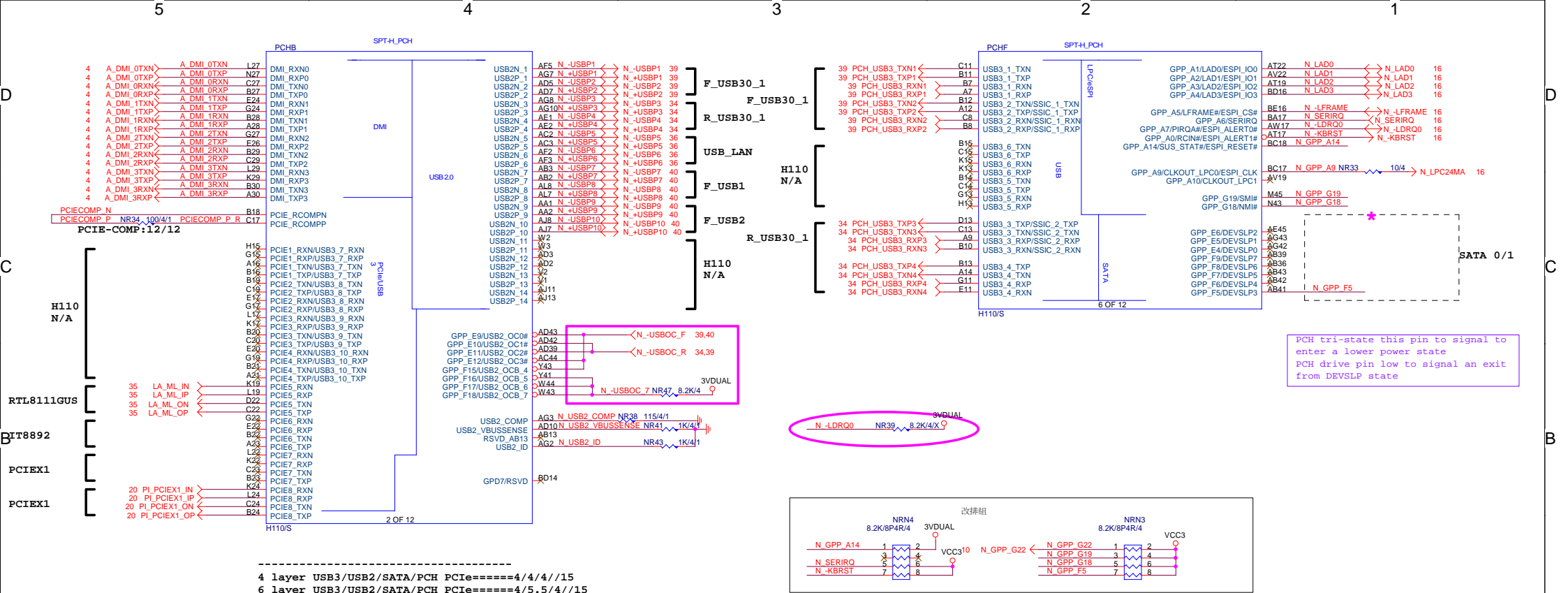

ANS 4353298 **Gigabyte Technology**

Title: **PCH DMI,USB,PCIE**

Size: Document Number Rev: **1.0**

Customer: **GA-H110M-S2V**

Date: Wednesday, March 09, 2016 Sheet 11 of 47



RTL8111GUS

BIT8892

PCIEX1

PCIEX1

5

4

3

2

1

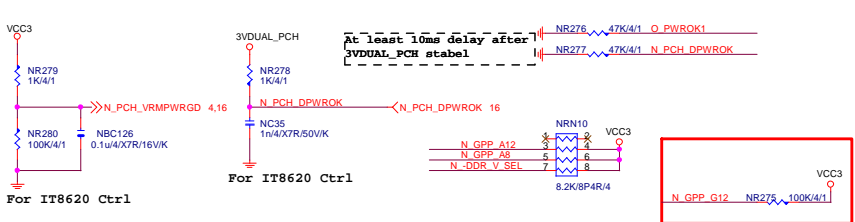
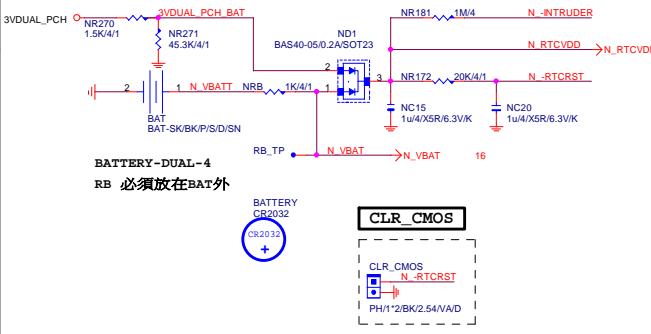
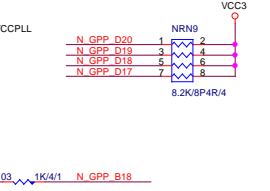
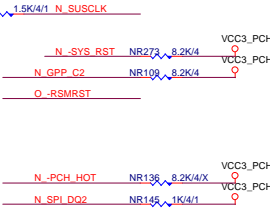
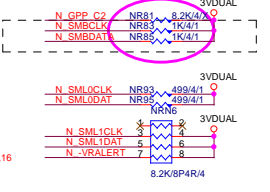
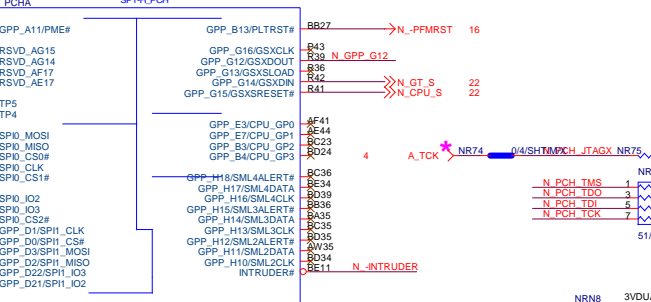
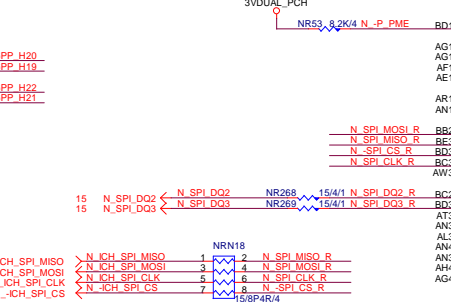
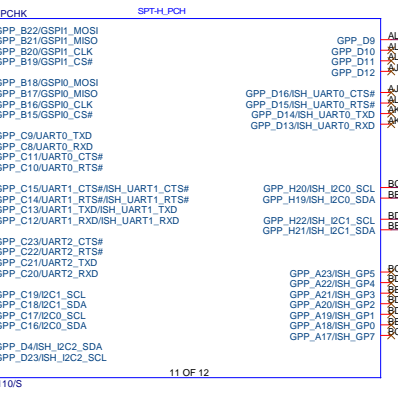
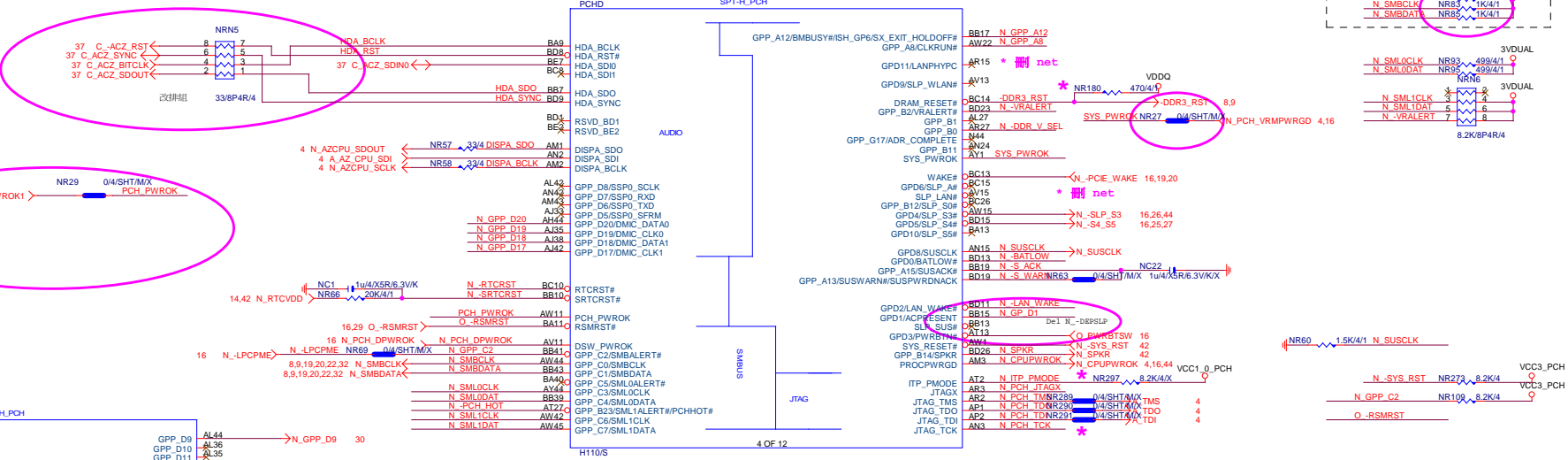

ANS 4353298
Gigabyte Technology
PCH MISC
GA-H110M-S2V
Date: Wednesday, March 09, 2016
Sheet 12 of 47

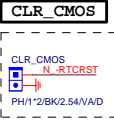

BATTERY-DUAL-4
RB 必須放在BAT外

N_INTERMEN: Integrated
1.05V SUS VRM Enable

At least 10ms delay after
3VDUAL_PCH stable

For IT8620 Ctrl

For IT8620 Ctrl

Rev 1.0

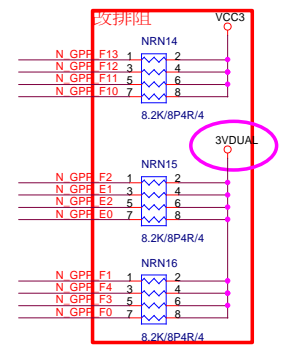
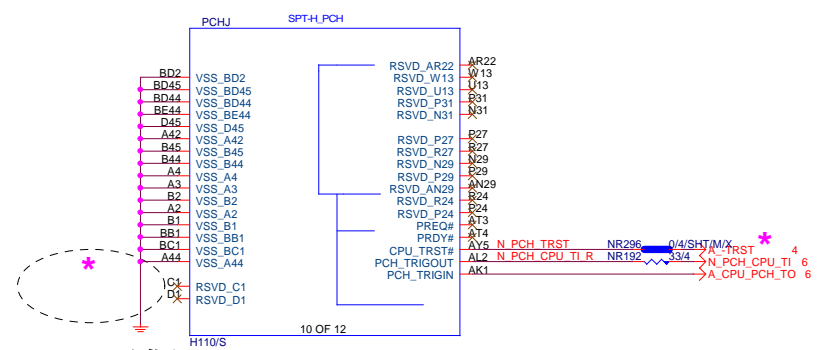
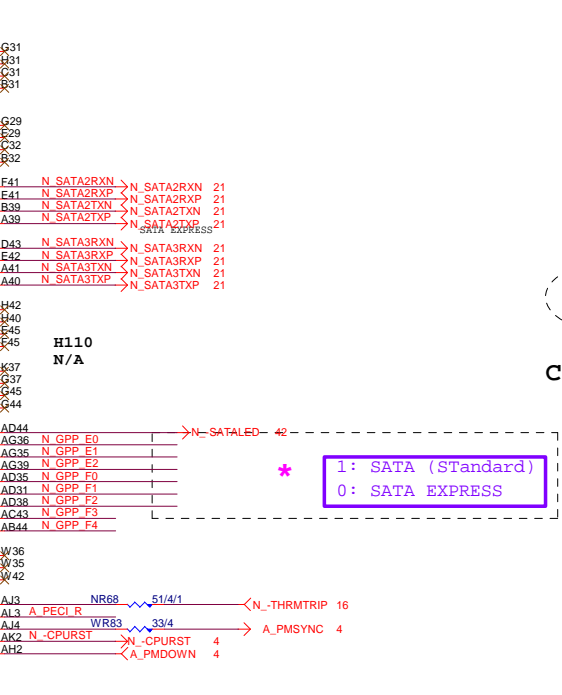
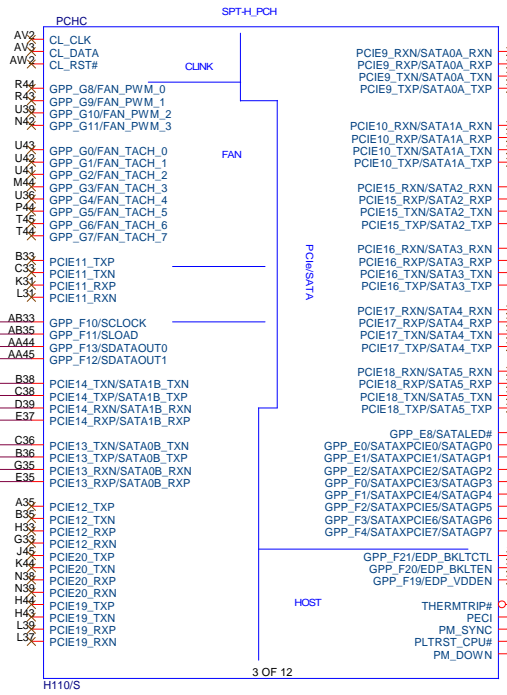

| | | | |
|-----------------------------------|---------------------------|----------------------------|----------|
| ANS 4353298 | | Gigabyte Technology | |
| Title | | | |
| PCH SATA,PCIE,SATA_EXPRESS | | | |
| Size | Document Number | Rev | |
| Custom | GA-H110M-S2V | 1.0 | |
| Date: | Wednesday, March 09, 2016 | Sheet | 13 of 47 |

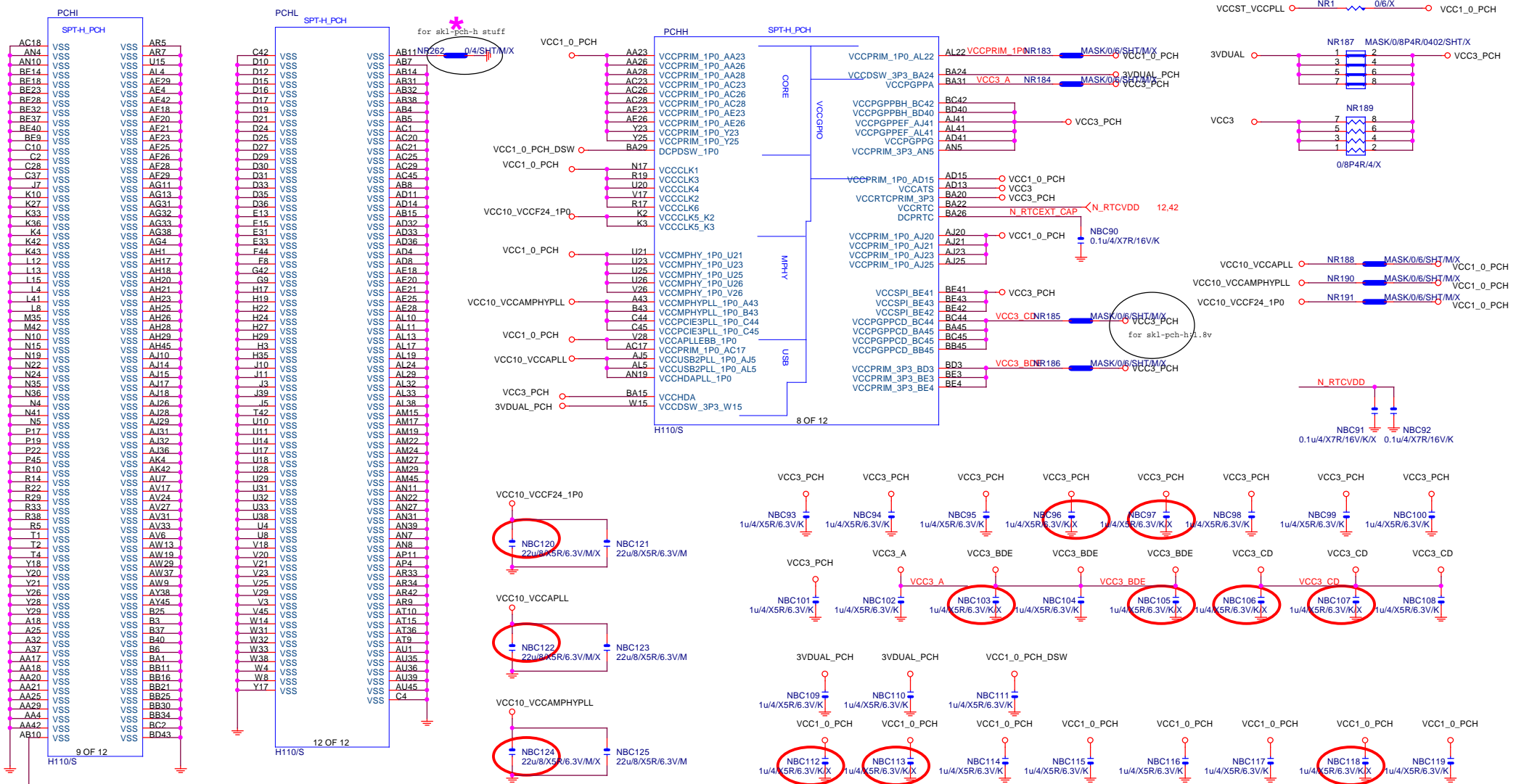

| | | | |
|---------------------|---------------------------|----------------------------|----------|
| ANS 4353298 | | Gigabyte Technology | |
| Title | | | |
| PCH PWR, GND | | | |
| Size | Document Number | Rev | |
| Custom | GA-H110M-S2V | 1.0 | |
| Date: | Wednesday, March 09, 2016 | Sheet | 14 of 47 |

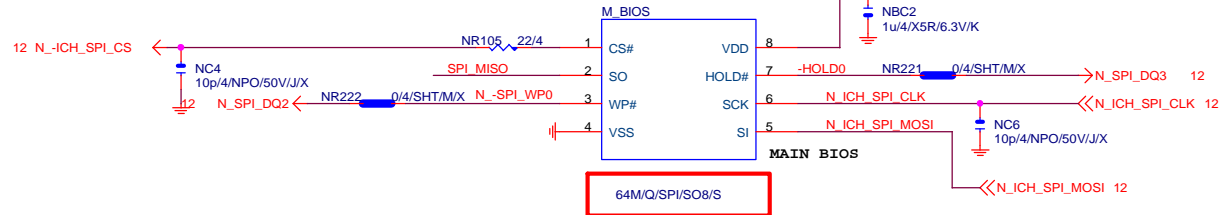
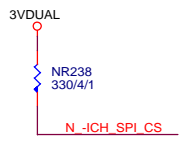

64M/Q/SPI/SO8/S

* (footprint 改 SOIC8-SPI-SOCKET)

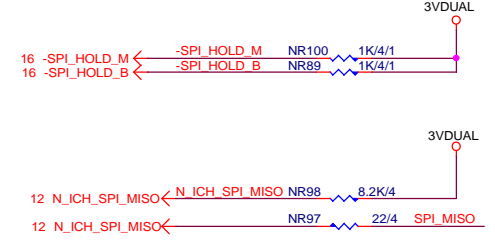

| BOOT DEVICE | GNT0 | GNT1 |
|-------------|------|------|
| LPC | 0 | 0 |
| PCI | 0 | 1 |
| NAND | 1 | 0 |
| SPI | 1 | 1 |

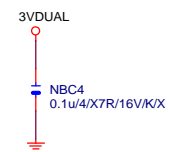

1 means floating
0 means PD 1K

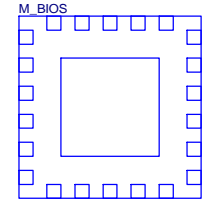

LCP/G-FL/1.27mm/200MIL/WHITE[10SL2-000008-31R]X

* 試産先上, PVT 移除

BIOS_PH

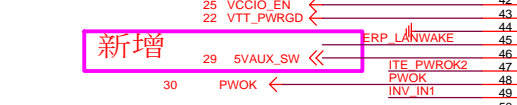
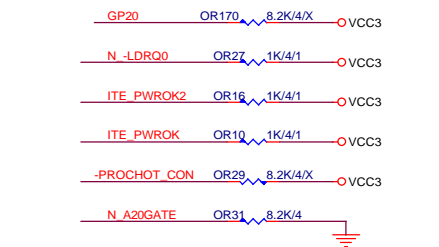
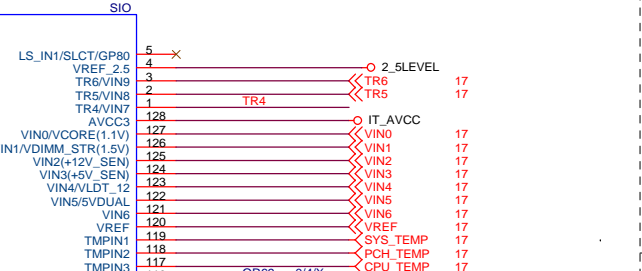
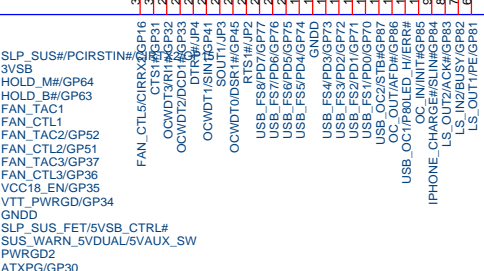
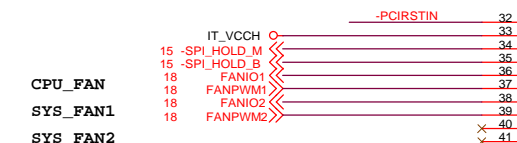
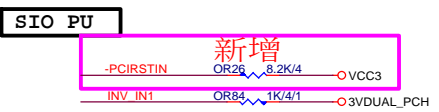
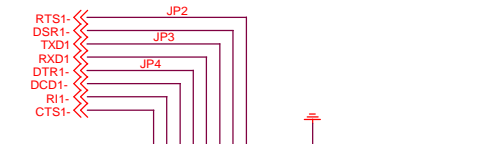

IT8628E_BX

IT8628E_BX

SIO STRAP

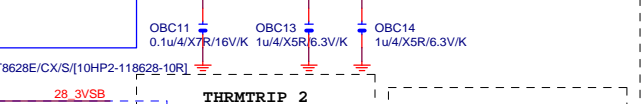
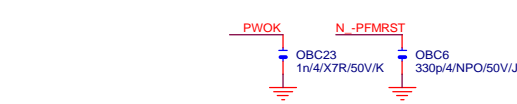
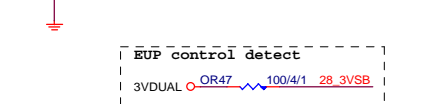
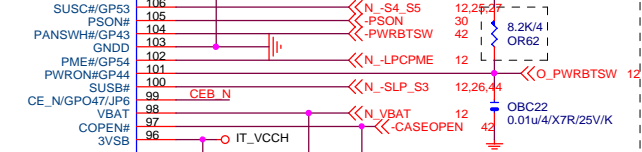
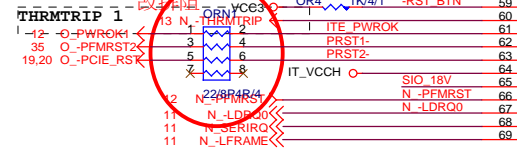
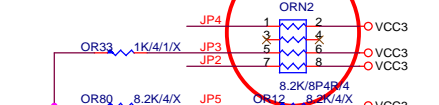

Table with 2 columns: JP (JP2, JP3, JP4, JP5) and Description (Disable WDT, Enable WDT to rest PWROK, SPI-Flash Disable, etc.).

Placement CPU
4 A_THRMTRIP WR110_1K/4/1 N_THRMTRIP

Placement CPU
4 A_THRMTRIP WR110_1K/4/1 N_THRMTRIP

Placement CPU
4 A_THRMTRIP WR110_1K/4/1 N_THRMTRIP

ERP WAKE on LAN (依LAN組態選擇)

CPU 端 A_THRMTRIP不可與PCH及SIO N_THRMTRIP直接連接。否則會出現無法拉LOW情況。

CPU 端 A_THRMTRIP不可與PCH及SIO N_THRMTRIP直接連接。否則會出現無法拉LOW情況。

CPU 端 A_THRMTRIP不可與PCH及SIO N_THRMTRIP直接連接。否則會出現無法拉LOW情況。

FAN TABLE with columns for Fan Name and Pin (CPU_FAN, SYS_FAN1, SYS_FAN2, SYS_FAN3, OPT_FAN or SYS_FAN4, THRMTRIP1, THRMTRIP2).

IT8620E GPIO問題匯整 table with columns for Pin, Description, and Action.

DUAL BIOS OPT STRAP

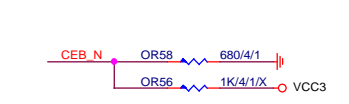

Power leakage

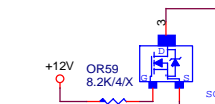

SIO_18V

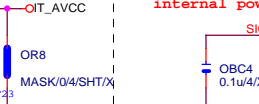

SIO CAP



IT_VCCH

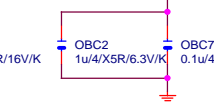

IT_AVCC

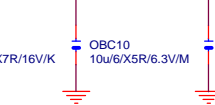

3VDUAL_PCH



2_5LEVEL

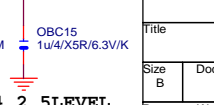

2_5LEVEL

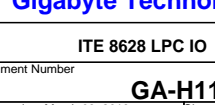

Realtek/ATHEROS LAN

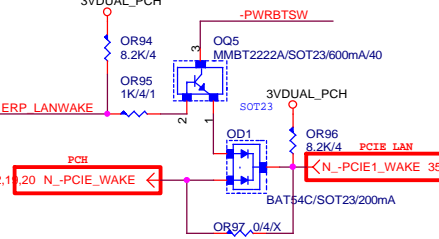

Gigabyte Technology logo and title block for ITE 8628 LPC IO, GA-H110M-S2V, Rev 1.0.

TEMP H/W MONITOR REV 1.04

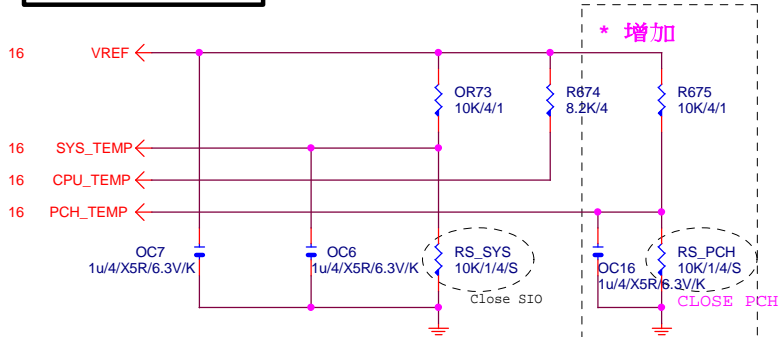

RS_VCORE ~ RS_VCCGT_CLOSE CPU_VCORE & VCCGT MOSFET

~~PROCHOT: 有mos heartsink不用prochot function~~

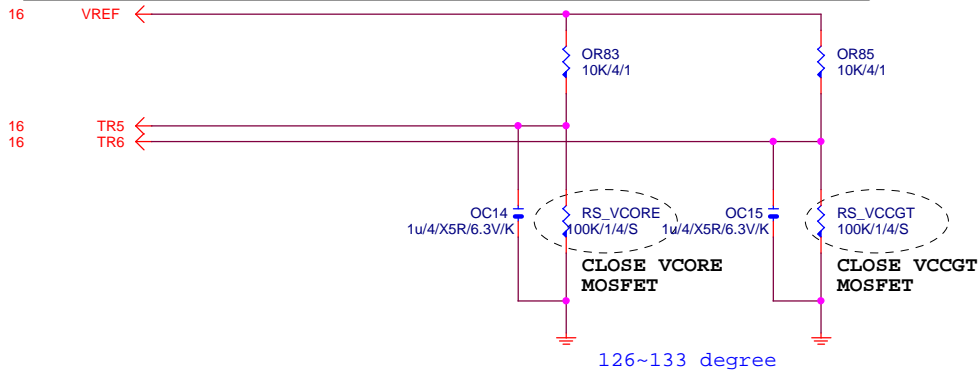

VOLTAGE-- H/W MONITOR

Connect to PWM

- * IT8728 BX
- ** IT8728 CX

Connect to PWM

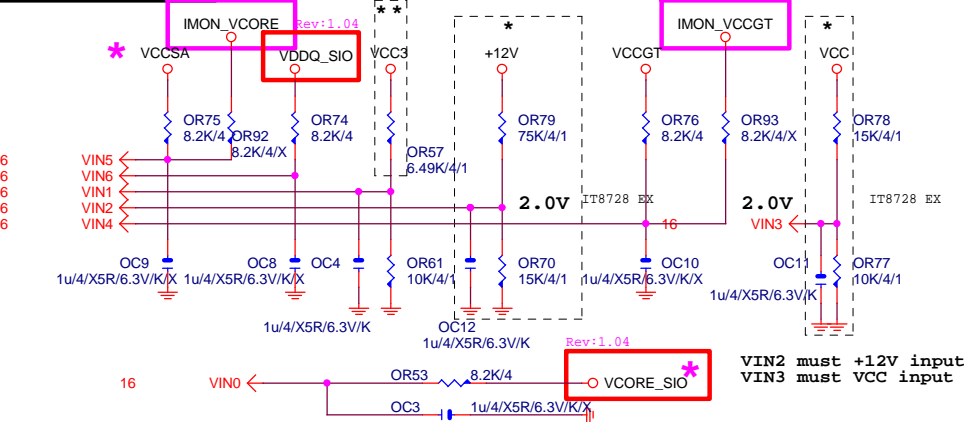

The division voltage of VIN2 & VIN3 must be around 2.9V

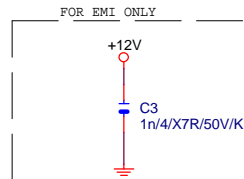

Gigabyte Technology

| | | |
|---------------------|---------------------------|----------------|
| Title | | |
| HWM,KB/MS, FAN CTRL | | |
| Size | Document Number | Rev |
| Custom | GA-H110M-S2V | 1.0 |
| Date: | Wednesday, March 09, 2016 | Sheet 17 of 47 |

CPU SMART FAN

Rev: 0.51

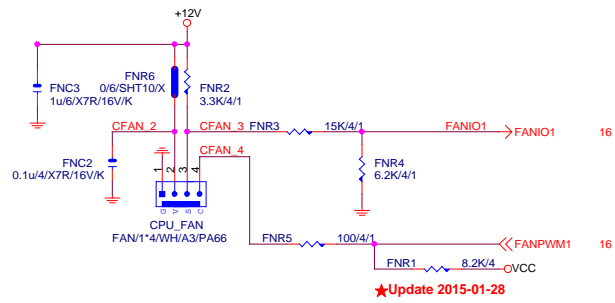

SYSTEM FAN1

Linear SYS_FAN

Enable Function (NCT3941S)
Full Turn On Function (NCT3941S-A)

A.

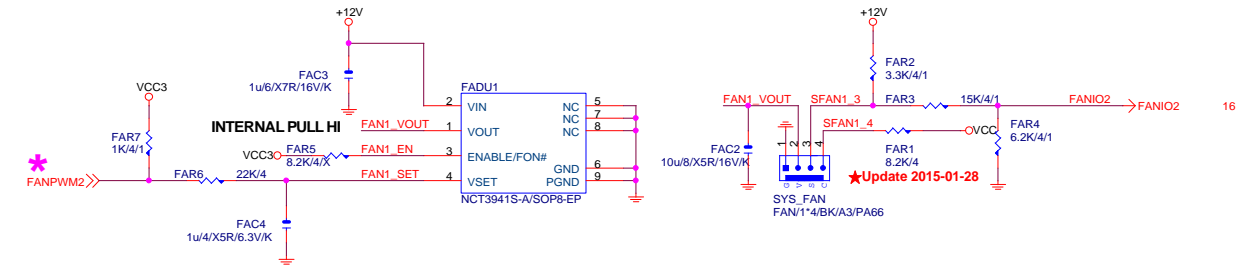

Gigabyte Technology

| | | |
|--------|---------------------------|----------------|
| Title | | FAN CTRL |
| Size | Document Number | Rev |
| Custom | GA-H110M-S2V | 1.0 |
| Date: | Wednesday, March 09, 2016 | Sheet 18 of 47 |

+12_protect
short-wire test

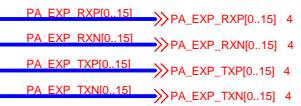
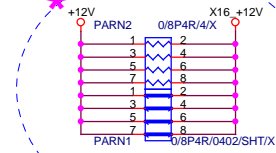

| | | | |
|--------------|-------|------------------|----------------|
| PA_EXP_TXP0 | PAC5 | 0.22u4/X5R6.3V/K | PA_EXP_TXP0_C |
| PA_EXP_TXN0 | PAC4 | 0.22u4/X5R6.3V/K | PA_EXP_TXN0_C |
| PA_EXP_TXP1 | PAC6 | 0.22u4/X5R6.3V/K | PA_EXP_TXP1_C |
| PA_EXP_TXN1 | PAC7 | 0.22u4/X5R6.3V/K | PA_EXP_TXN1_C |
| PA_EXP_TXP2 | PAC8 | 0.22u4/X5R6.3V/K | PA_EXP_TXP2_C |
| PA_EXP_TXN2 | PAC9 | 0.22u4/X5R6.3V/K | PA_EXP_TXN2_C |
| PA_EXP_TXP3 | PAC10 | 0.22u4/X5R6.3V/K | PA_EXP_TXP3_C |
| PA_EXP_TXN3 | PAC11 | 0.22u4/X5R6.3V/K | PA_EXP_TXN3_C |
| PA_EXP_TXP4 | PAC12 | 0.22u4/X5R6.3V/K | PA_EXP_TXP4_C |
| PA_EXP_TXN4 | PAC13 | 0.22u4/X5R6.3V/K | PA_EXP_TXN4_C |
| PA_EXP_TXP5 | PAC14 | 0.22u4/X5R6.3V/K | PA_EXP_TXP5_C |
| PA_EXP_TXN5 | PAC15 | 0.22u4/X5R6.3V/K | PA_EXP_TXN5_C |
| PA_EXP_TXP6 | PAC16 | 0.22u4/X5R6.3V/K | PA_EXP_TXP6_C |
| PA_EXP_TXN6 | PAC17 | 0.22u4/X5R6.3V/K | PA_EXP_TXN6_C |
| PA_EXP_TXP7 | PAC18 | 0.22u4/X5R6.3V/K | PA_EXP_TXP7_C |
| PA_EXP_TXN7 | PAC19 | 0.22u4/X5R6.3V/K | PA_EXP_TXN7_C |
| PA_EXP_TXP8 | PAC21 | 0.22u4/X5R6.3V/K | PA_EXP_TXP8_C |
| PA_EXP_TXN8 | PAC20 | 0.22u4/X5R6.3V/K | PA_EXP_TXN8_C |
| PA_EXP_TXP9 | PAC22 | 0.22u4/X5R6.3V/K | PA_EXP_TXP9_C |
| PA_EXP_TXN9 | PAC23 | 0.22u4/X5R6.3V/K | PA_EXP_TXN9_C |
| PA_EXP_TXP10 | PAC24 | 0.22u4/X5R6.3V/K | PA_EXP_TXP10_C |
| PA_EXP_TXN10 | PAC25 | 0.22u4/X5R6.3V/K | PA_EXP_TXN10_C |
| PA_EXP_TXP11 | PAC26 | 0.22u4/X5R6.3V/K | PA_EXP_TXP11_C |
| PA_EXP_TXN11 | PAC27 | 0.22u4/X5R6.3V/K | PA_EXP_TXN11_C |
| PA_EXP_TXP12 | PAC28 | 0.22u4/X5R6.3V/K | PA_EXP_TXP12_C |
| PA_EXP_TXN12 | PAC29 | 0.22u4/X5R6.3V/K | PA_EXP_TXN12_C |
| PA_EXP_TXP13 | PAC30 | 0.22u4/X5R6.3V/K | PA_EXP_TXP13_C |
| PA_EXP_TXN13 | PAC31 | 0.22u4/X5R6.3V/K | PA_EXP_TXN13_C |
| PA_EXP_TXP14 | PAC32 | 0.22u4/X5R6.3V/K | PA_EXP_TXP14_C |
| PA_EXP_TXN14 | PAC33 | 0.22u4/X5R6.3V/K | PA_EXP_TXN14_C |
| PA_EXP_TXP15 | PAC34 | 0.22u4/X5R6.3V/K | PA_EXP_TXP15_C |
| PA_EXP_TXN15 | PAC35 | 0.22u4/X5R6.3V/K | PA_EXP_TXN15_C |

PCIE16:16/5/5/5/16

PCI-E REV:1.1--> 2.5GHZ

PCE-E X1(單向) BANDWIDTH=2.5GHz*(8b/10b)=2Gb/s=250MB/s

PCE-E X1(雙向) BANDWIDTH=2.5GHz*(8b/10b)X2=4Gb/s=500MB/s

PCE-E X16(單向) BANDWIDTH=2.5GHz*(8b/10b)X16=32Gb/s=4GB/s

PCE-E X16(雙向) BANDWIDTH=2.5GHz*(8b/10b)X16X2=64Gb/s=8GB/s

PCI-E REV:2.0--> 5GHZ

PCIESLOT-1645TH

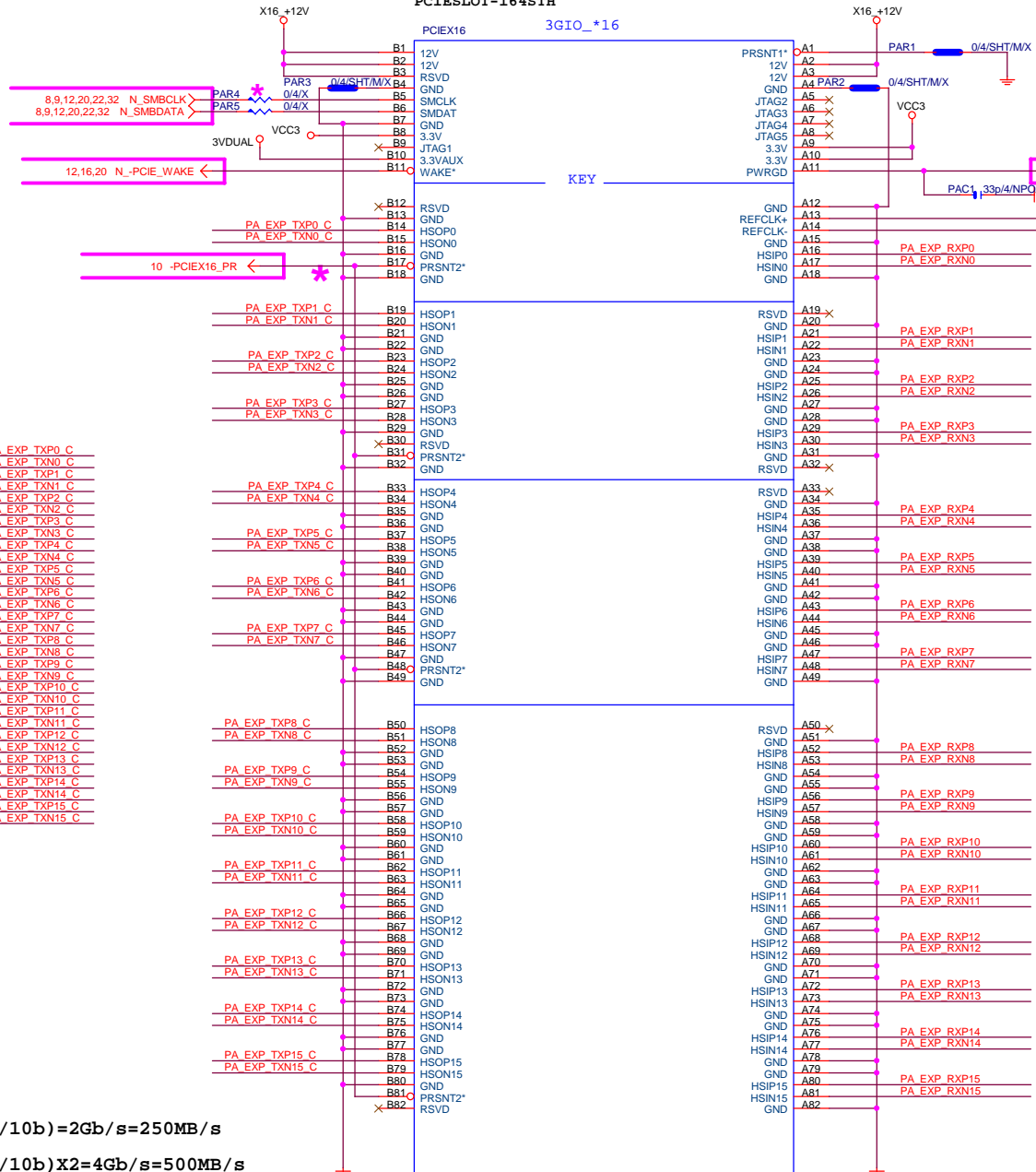

PCI-E/16x-164P/GY/LONG DOUBLE/HK*2

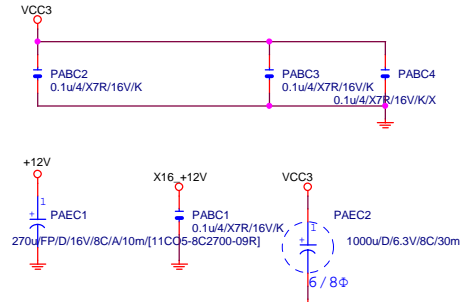

| | | |
|----------------------------|---------------------------|----------------|
| Gigabyte Technology | | |
| PCI EXPRESS * 16 | | |
| Title | | |
| Size Custom | Document Number | Rev |
| | GA-H110M-S2V | 1.0 |
| Date: | Wednesday, March 09, 2016 | Sheet 19 of 47 |

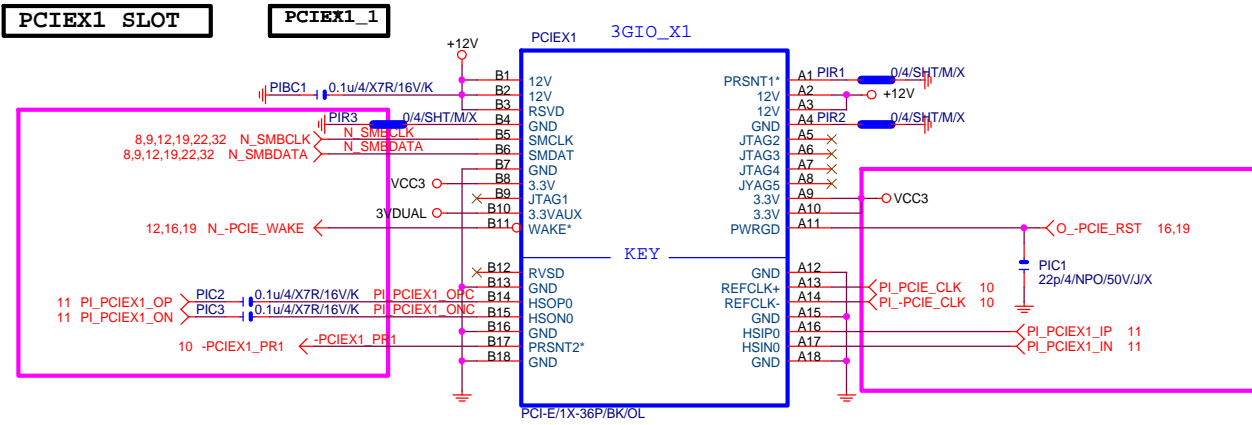

| | | | |
|----------------------------|---------------------------|------------|----------|
| Gigabyte Technology | | | |
| PCIE_X1 1,2 | | | |
| Size | Document Number | Rev | |
| Custom | GA-H110M-S2V | 1.0 | |
| Date: | Wednesday, March 09, 2016 | Sheet | 20 of 47 |

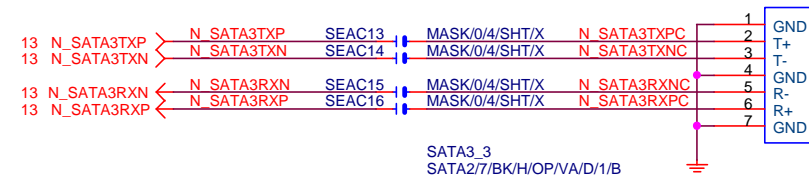
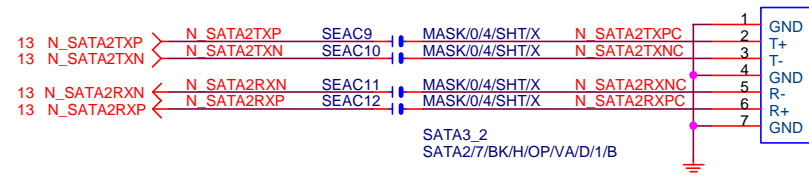
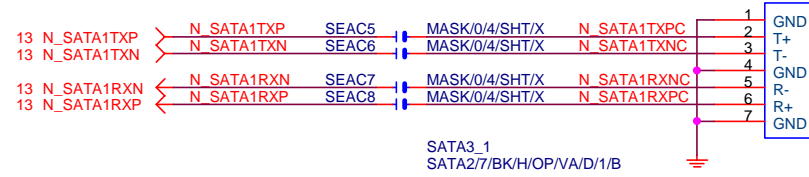
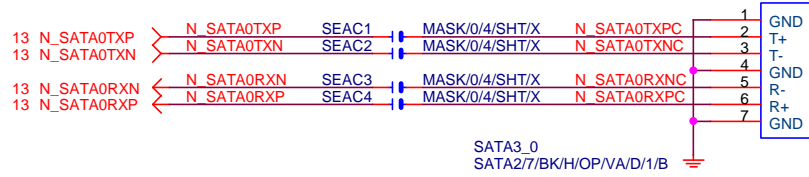

Gigabyte Technology

| | | | |
|--------------|---------------------------|-------|----------|
| Title | | | Rev |
| SATA EXPRESS | | | |
| Size | Document Number | | 1.0 |
| Custom | GA-H110M-S2V | | |
| Date: | Wednesday, March 09, 2016 | Sheet | 21 of 47 |

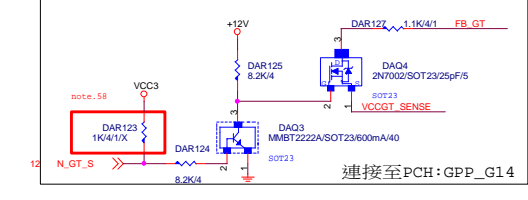
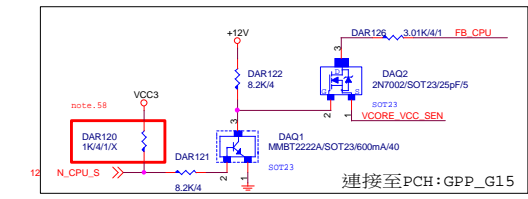
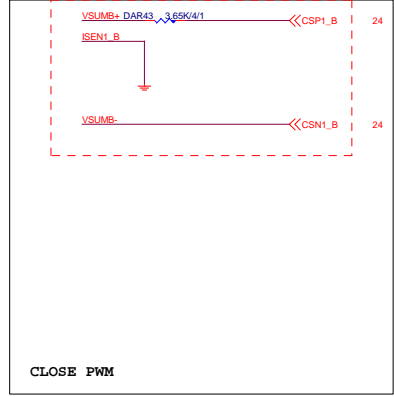
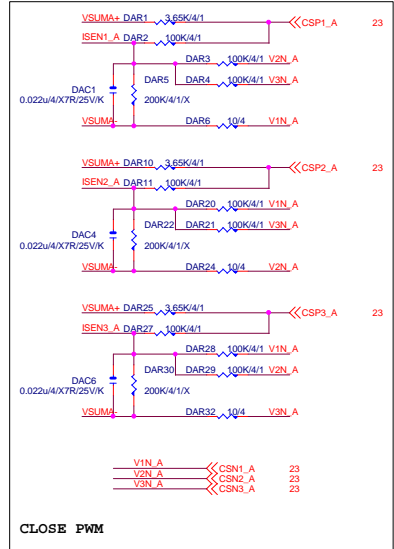
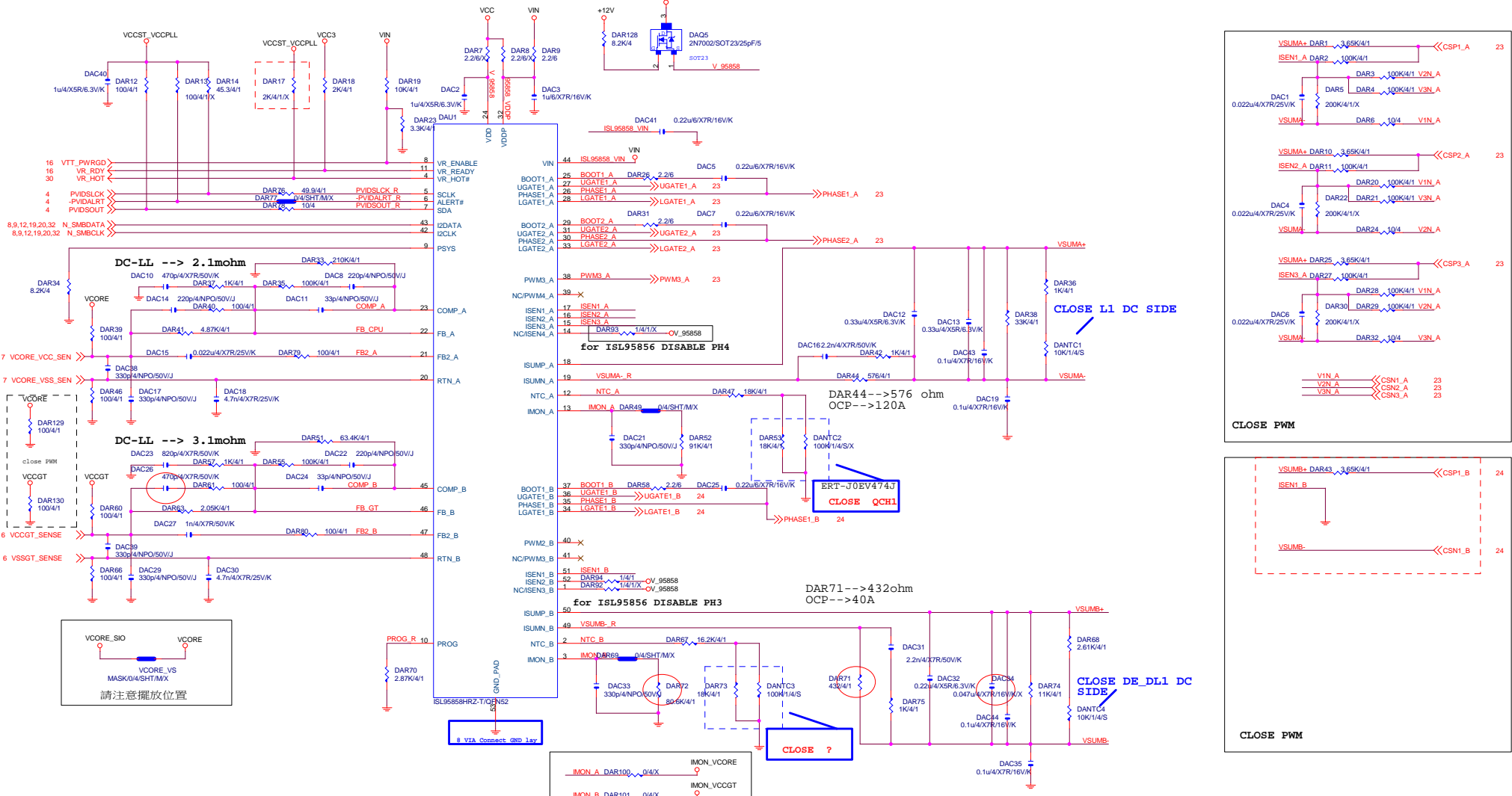

VCORE

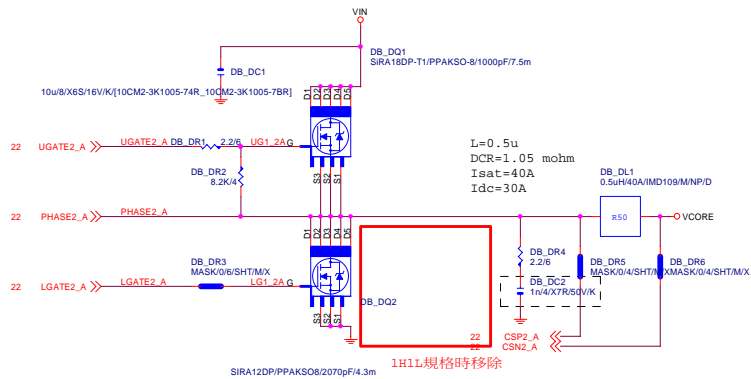
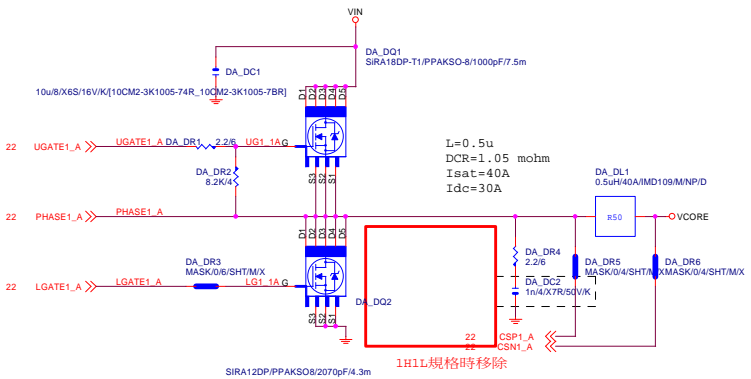

VIN CAP 270u*3PCS

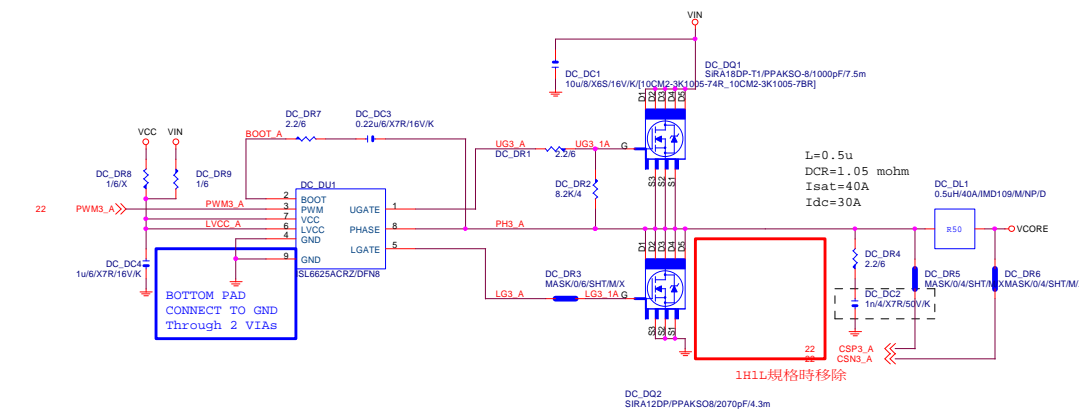
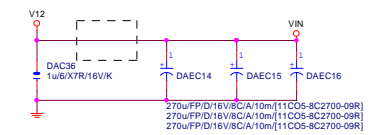

VCORE CAP 560u*4PCS 22u*10PCS

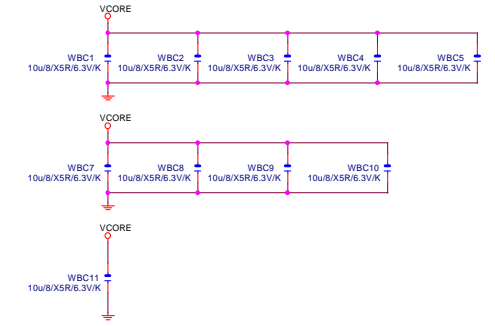
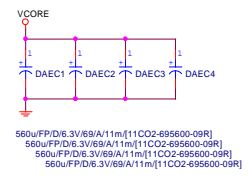

GIGABYTE™

Title: **ISL95858_MOS**

| | | |
|-------|---------------------------|----------------|
| Size | Document Number | Rev |
| Custm | GA-H110M-S2V | 1.0 |
| Date: | Wednesday, March 09, 2016 | Sheet 23 of 47 |

VCCGT

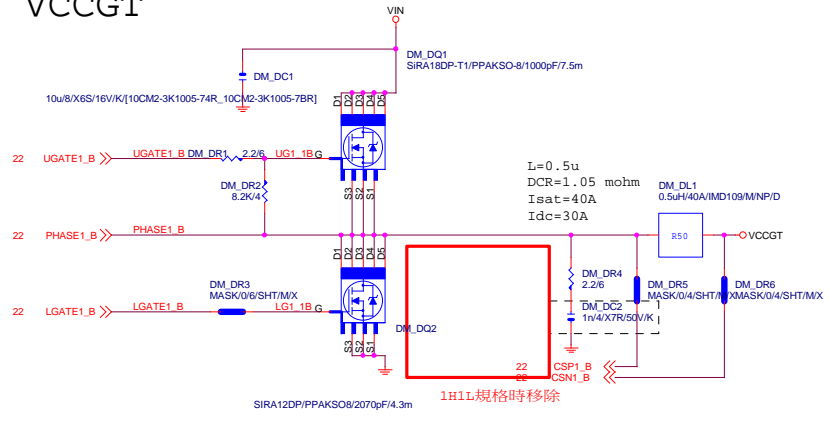

VCCGT CAP 560u*2PCS 22u*2PCS

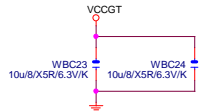
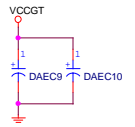

| | | |
|---------------------------------|--|-------------------|
| GIGABYTE™ | | |
| Title ISL95858_MOS | | |
| Size Custom | Document Number GA-H110M-S2V | Rev 1.0 |
| Date: Wednesday, March 09, 2016 | Sheet 24 | of 47 |

VCCSA REV:0.4

CCIO

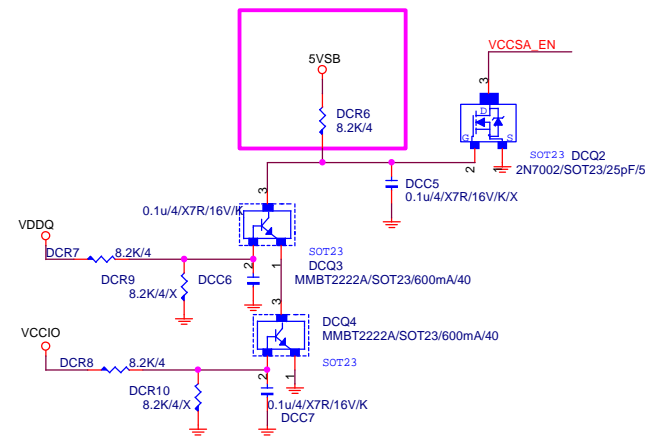
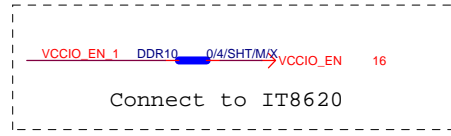
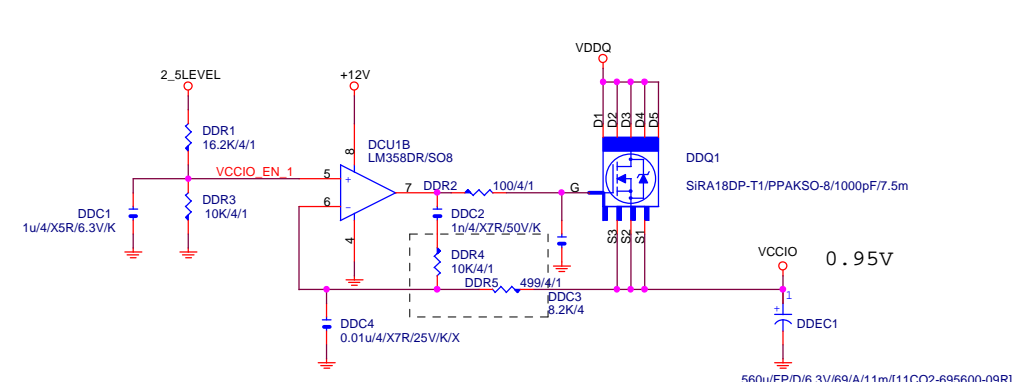
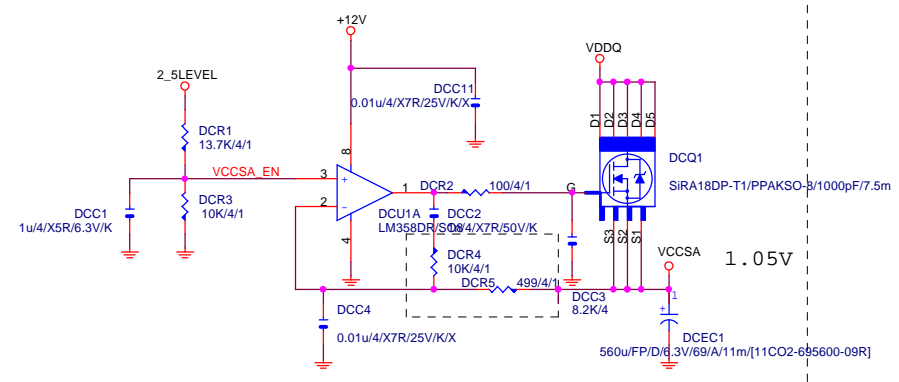

VCCST_VCCPLL

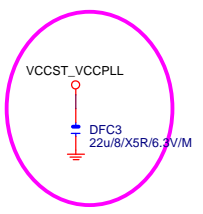
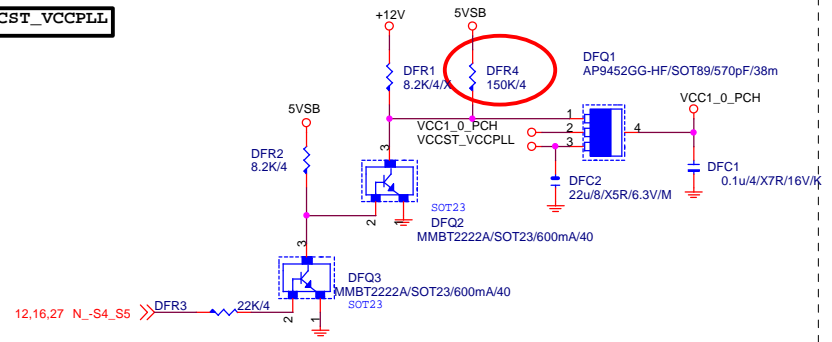

| | | |
|---------------------------------|-------------------------------------|----------------|
| GIGABYTE™ | | |
| Title VCCSA_VCCIO | | |
| Size Custom | Document Number GA-H110M-S2V | Rev 1.0 |
| Date: Wednesday, March 09, 2016 | Sheet 25 | of 47 |

DDR4

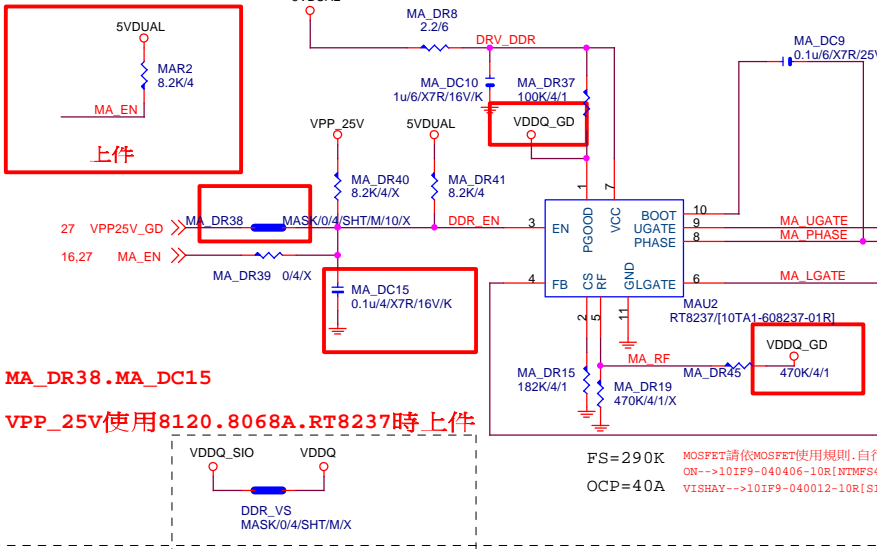

PIN7-->20mil
PIN1-->6mil
PIN2-->6mil
PIN5-->6mil
PIN3-->6mil

F'S=290K MOSFET請依MOSFET使用規則,自行選擇
ON-->101P9-040406-10R[NTMFS4C06N/N/PPAK/1400pF/4m]
VISHAY-->101F9-040012-10R[SIRA12DP/PPAKS08/2070pF/4.3m]

DDR VIN CAP 560u*1PCS

CHOKE與CAP料號可變

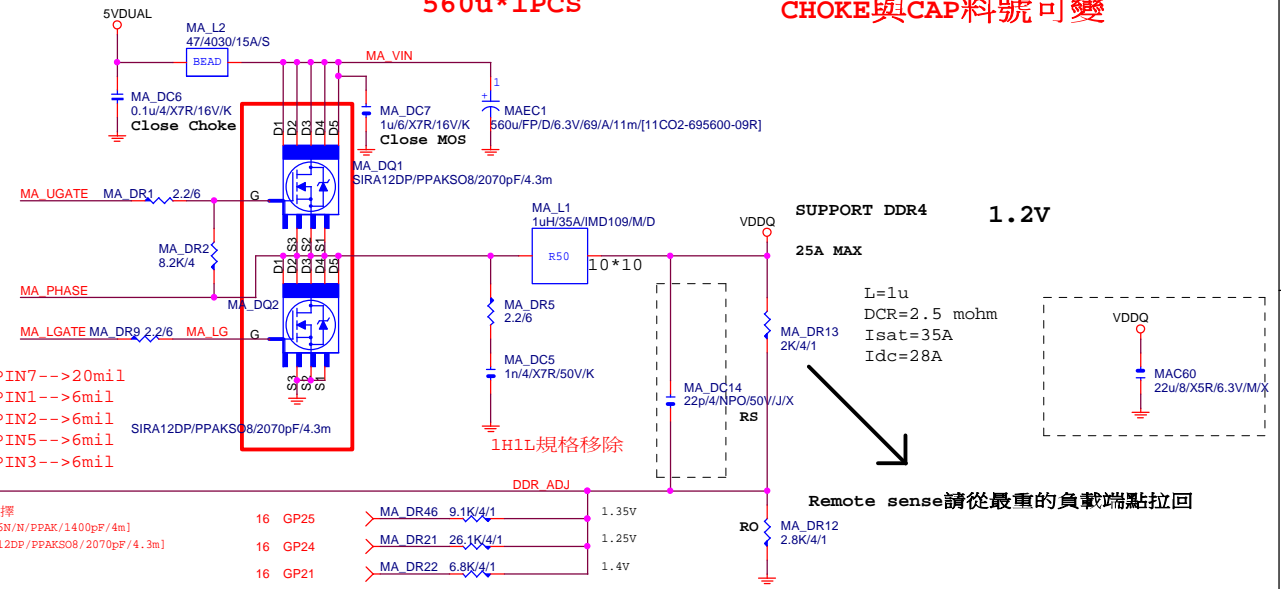

DDRVTT

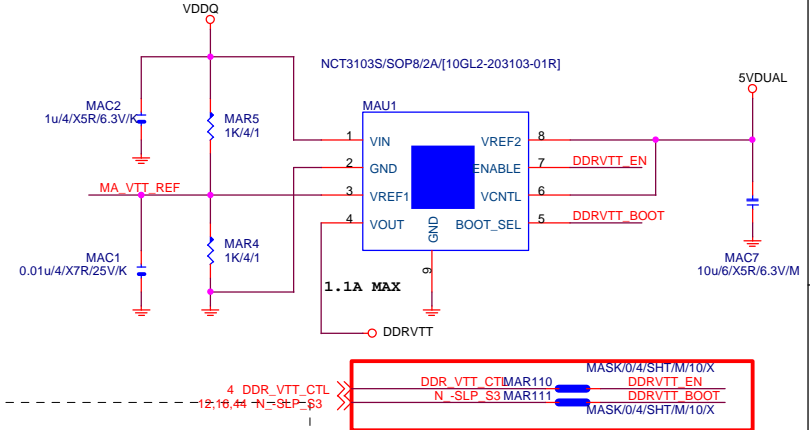

DDR CAP 560u*4PCS 22u*2PCS

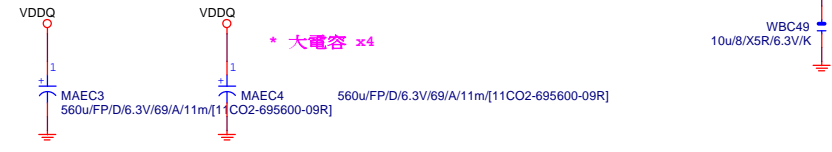

| | | |
|-----------------------------------|---------------------------|----------------|
| Title RT8237_DDR4 POWER | | |
| Size | Document Number | Rev |
| Custom | GA-H110M-H | 1.0 |
| Date: | Wednesday, March 09, 2016 | Sheet 26 of 47 |

VPP_25V

CHOKE與CAP料號可變

L=1u
DCR=3.2 mohm
Isat=18A
Idc=15A

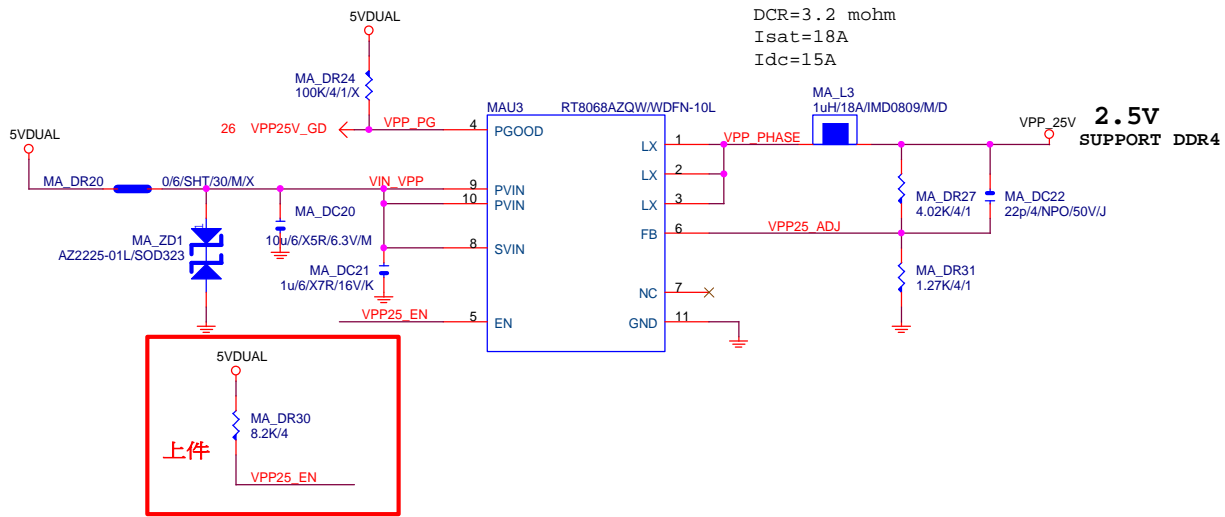

PWR_SEQ

* 刪 MA_DR32

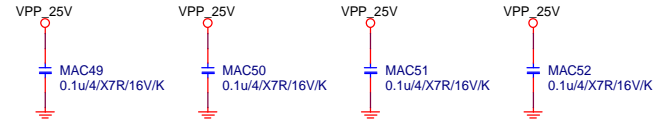
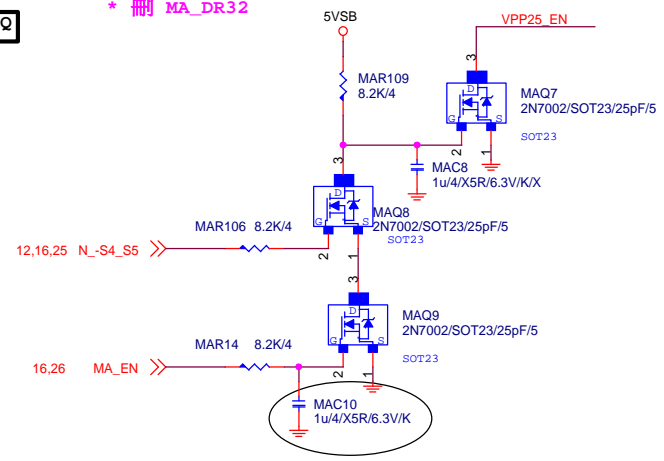

VPP CAP 22u*1PCS

* 大電容 x0

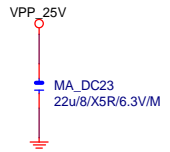

| | | |
|--------------------|---------------------------|----------------|
| Title | | |
| RT9018_VPP25 POWER | | |
| Size | Document Number | Rev |
| Custom | GA-H110M-S2V | 1.0 |
| Date: | Wednesday, March 09, 2016 | Sheet 27 of 47 |

REV:0.47

CHOKE與CAP料號可變

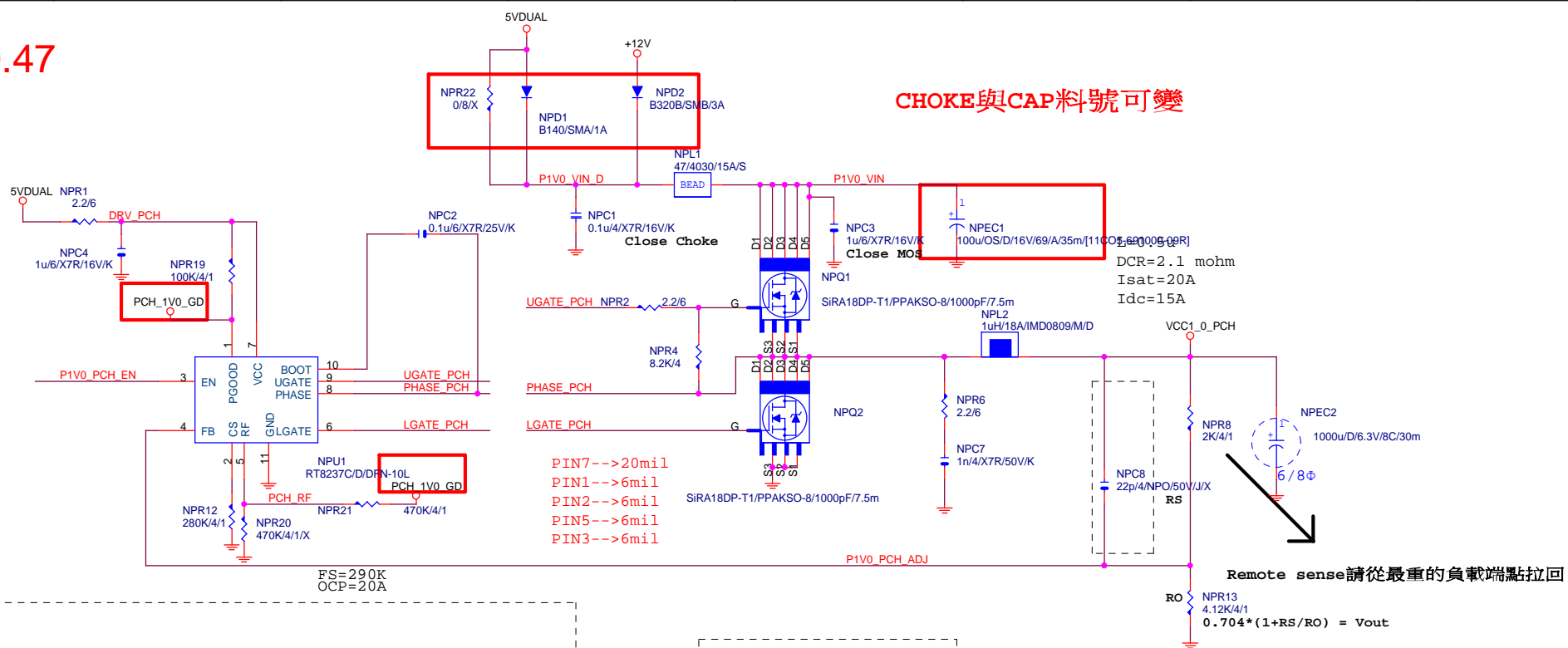

PWR SEQ

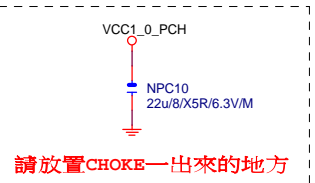
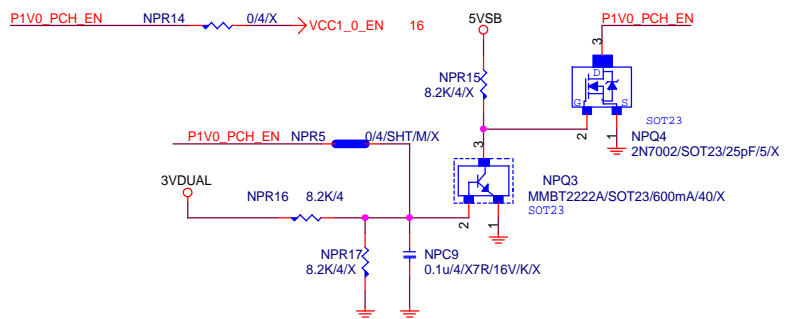

| | | | |
|------------------------------------|--|----------|-------------------|
| GIGABYTE™ | | | |
| Title RT8237_PCH POWER | | | |
| Size Custom | Document Number GA-H110M-S2V | | Rev 1.0 |
| Date: Wednesday, March 09, 2016 | Sheet 28 | of 47 | |

REV:0.51

5VDUAL

* update 5Vdual circuit
, from SKL 0.2B

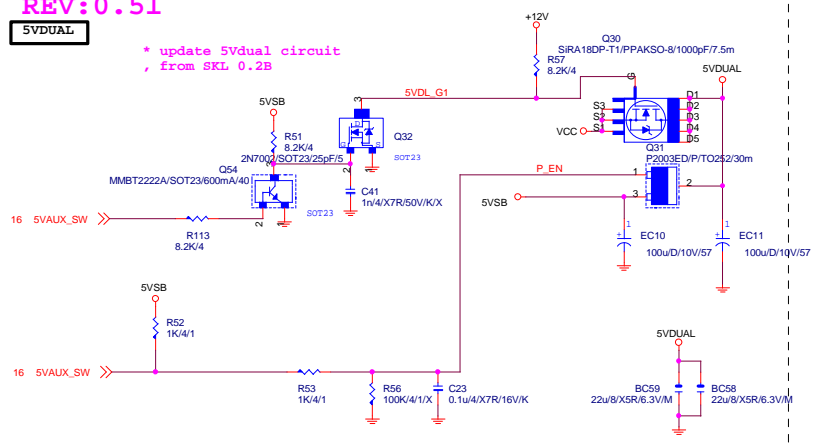

3VDUAL

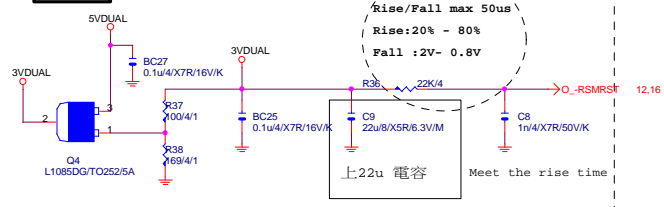

Rise/Fall max 50us
 Rise:20% - 80%
 Fall :2V- 0.8V

上22u 电容 Meet the rise time

3VDUAL_PCH

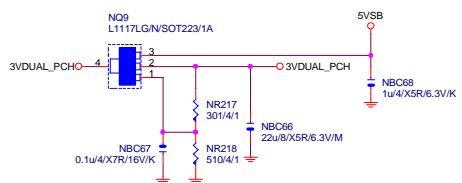

ATXX24 POWER CONNECTOR

ATXX4 POWER CONNECTOR

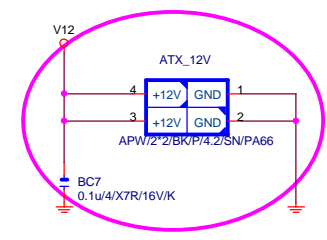
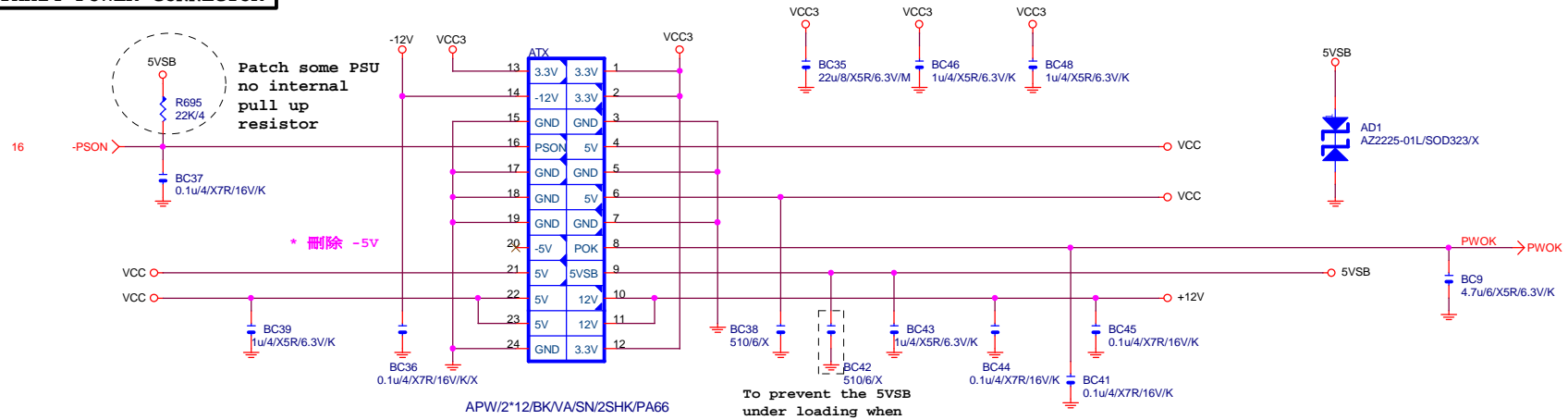

螺絲孔

MH1:GND-T FOR EMI TEST 驗證

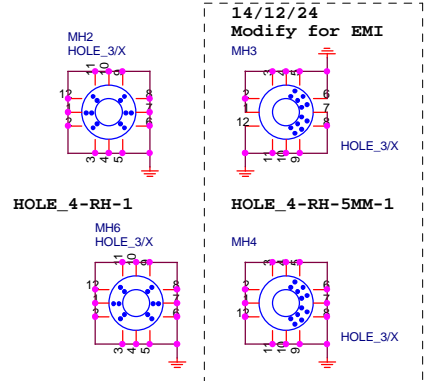

固定孔/光學點

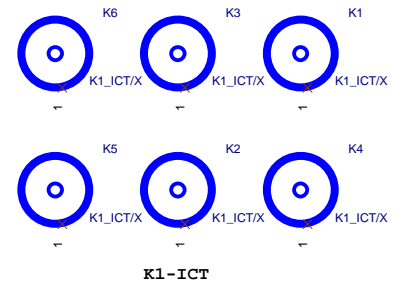

To prevent the 5VSB under loading when boot

+12V DUMMY LOAD

To fix 12V light load abnormal issue

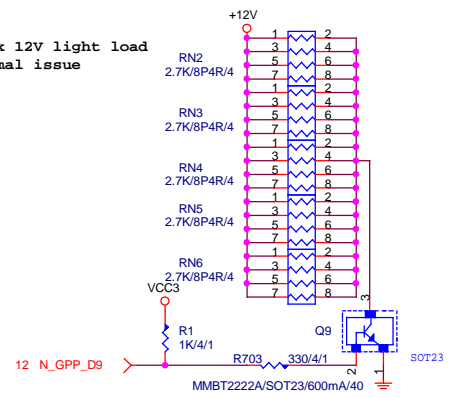

【技術通報R&D技術通報153】

DUMMY LOAD

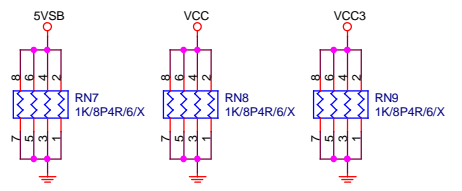

-PROHOT

* 保留 ?

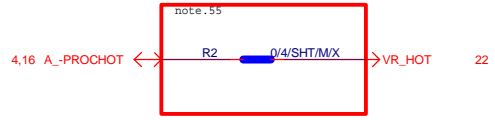

COUPON

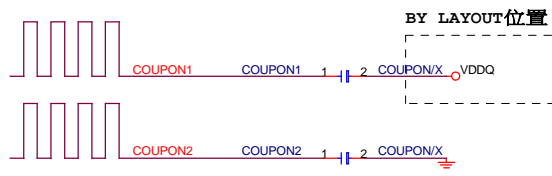

| | | |
|---------------------------------|-----------------|---------|
| Gigabyte Technology | | |
| Title | | |
| ATX POWER CONNECTOR | | |
| Size Custom | Document Number | Rev 1.0 |
| GA-H110M-S2V | | |
| Date: Wednesday, March 09, 2016 | Sheet 30 | of 47 |

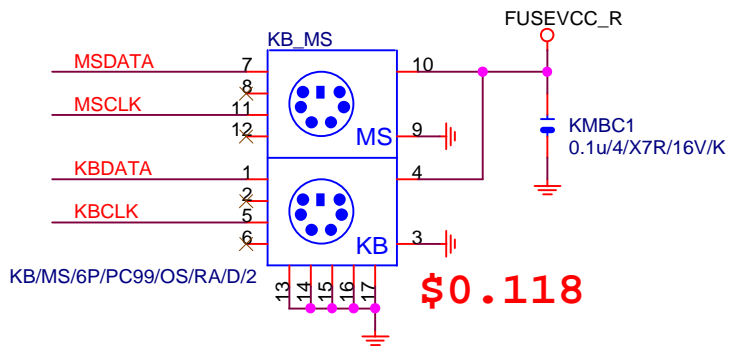

\$0.118

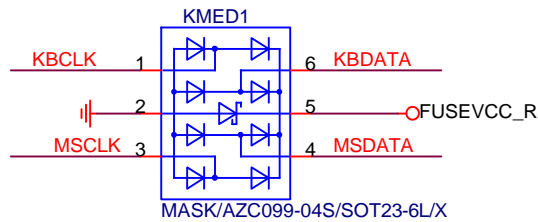

KB_MS_USB DAMPING/PU

KB_MS_USB PWR

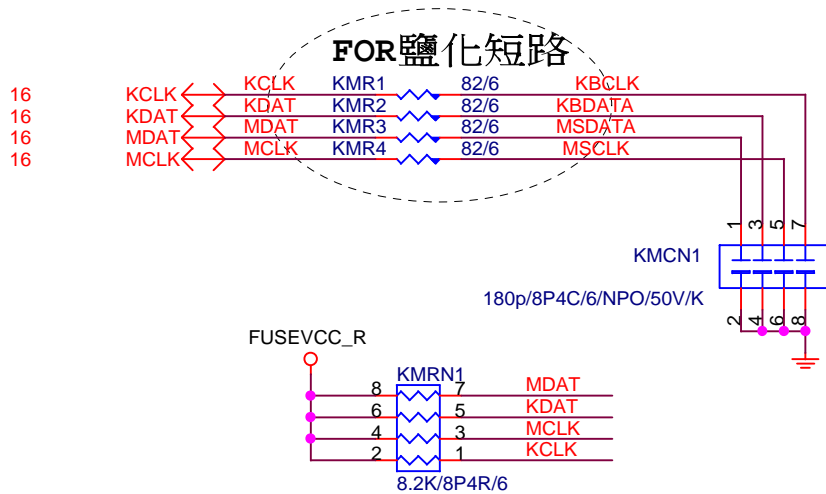

FOR 鹽化短路

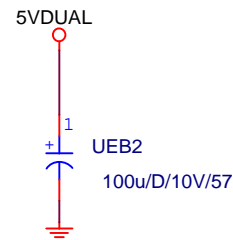

Gigabyte Technology

| | | |
|-----------|---------------------------|----------------|
| Title | | |
| KB_MS_USB | | |
| Size A | Document Number | Rev |
| | GA-H110M-S2V | 1.0 |
| Date: | Wednesday, March 09, 2016 | Sheet 31 of 47 |

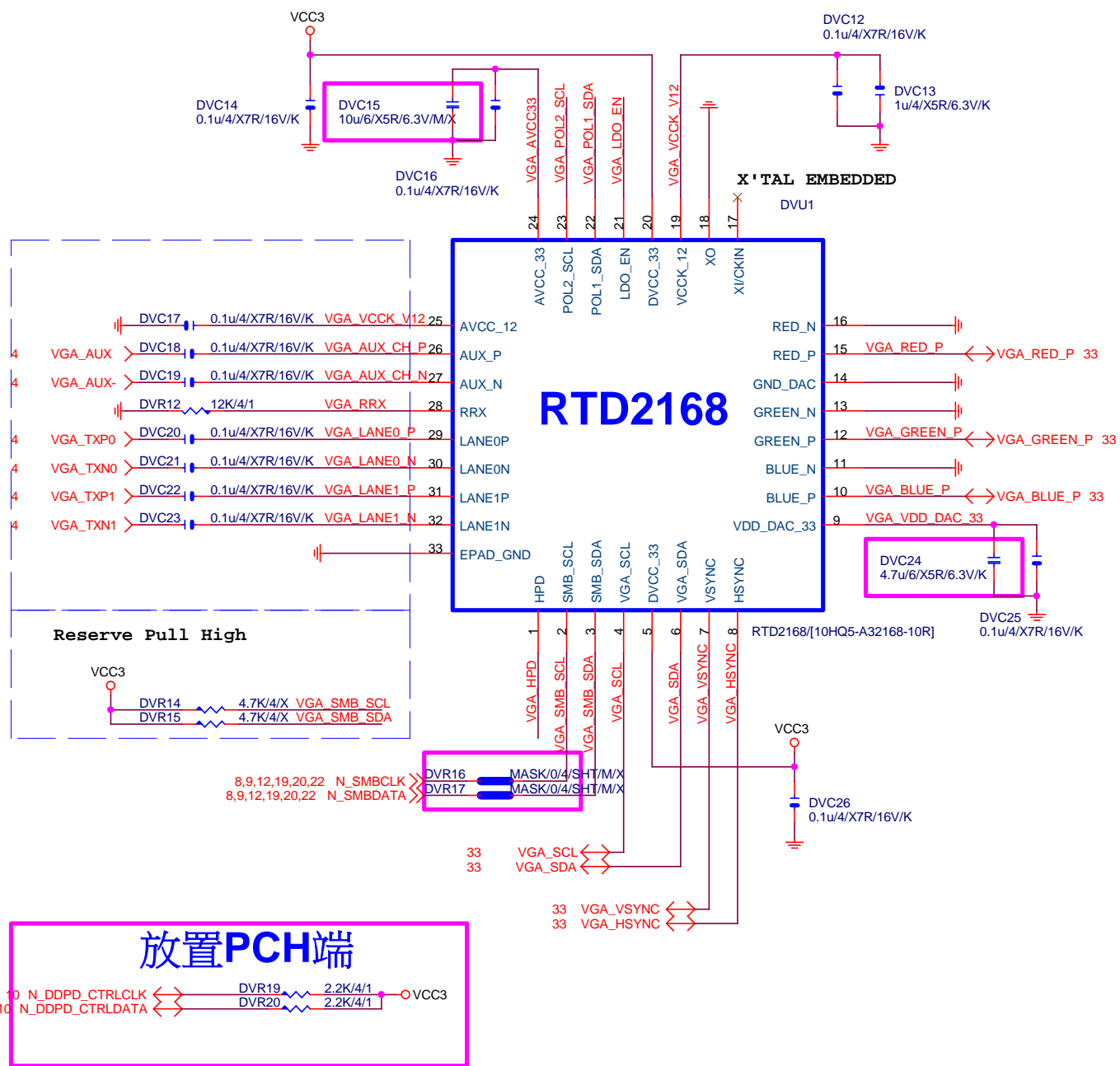

POWER

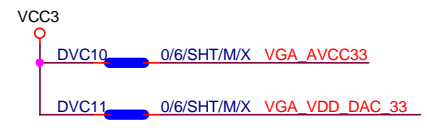

Power on latch

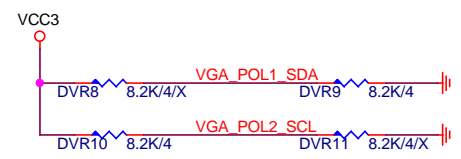

| | | POL1_SDA(PIN22) | |
|------------------|---|----------------------|-------------|
| | | 0 | 1 |
| POL2_SCL (PIN23) | 0 | X | EP MODE |
| | 1 | ROM ONLY MODE | EEPROM MODE |

Embedded LDO

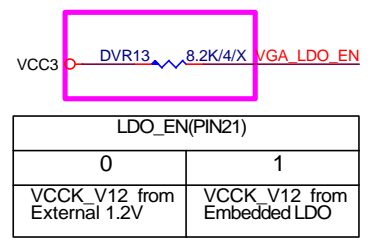

DP HPD

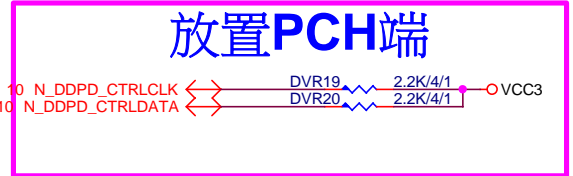
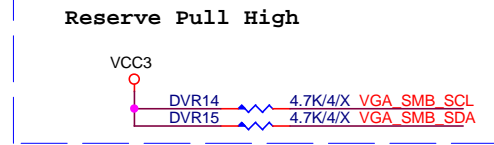

VGA SIGNAL R1.02

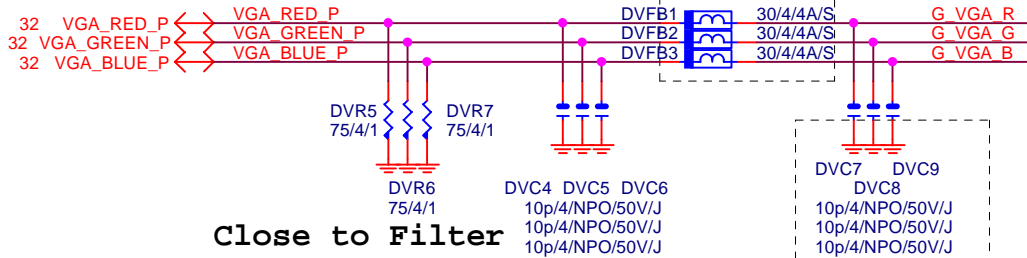
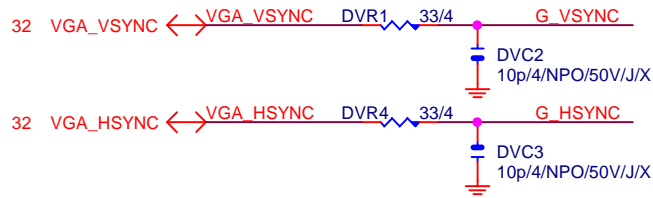
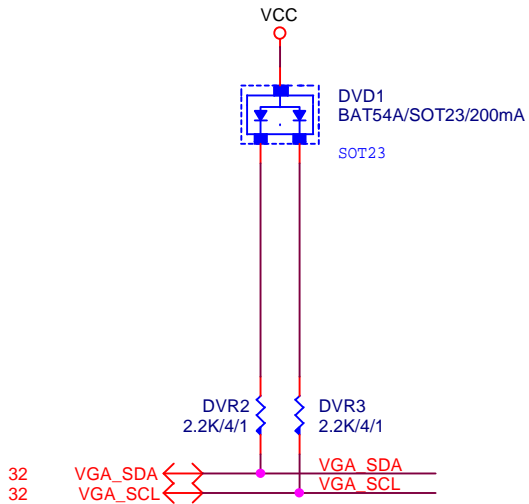

Close to Filter

FOR EMI

VGA CONN.

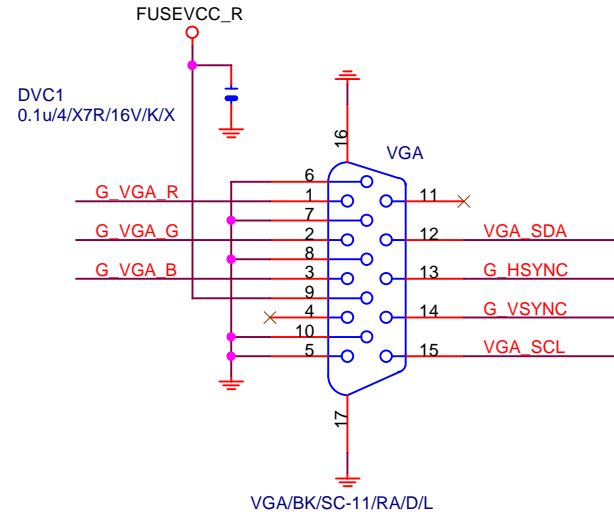

VGA ESD

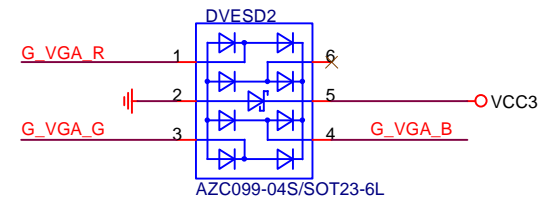
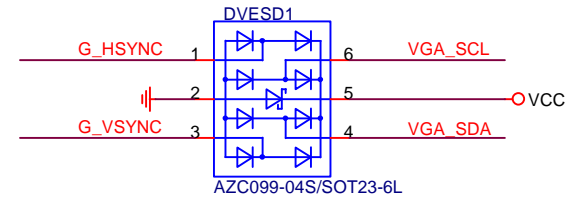

Gigabyte Technology
NXP-PTN3356

| | | |
|--------|---------------------------|----------------|
| Title | | |
| Size | Document Number | Rev |
| Custom | GA-H110M-S2V | 1.0 |
| Date: | Wednesday, March 09, 2016 | Sheet 33 of 47 |

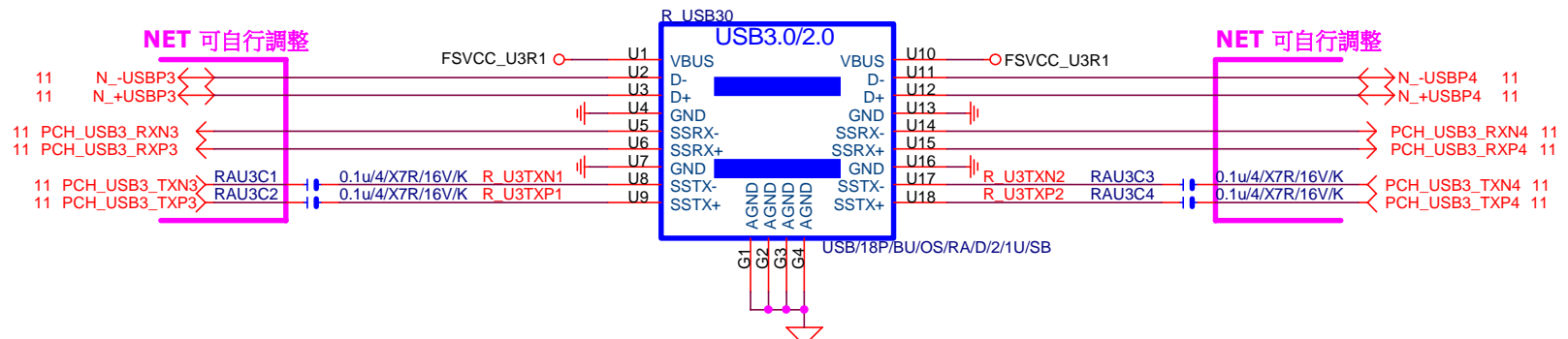

ESD

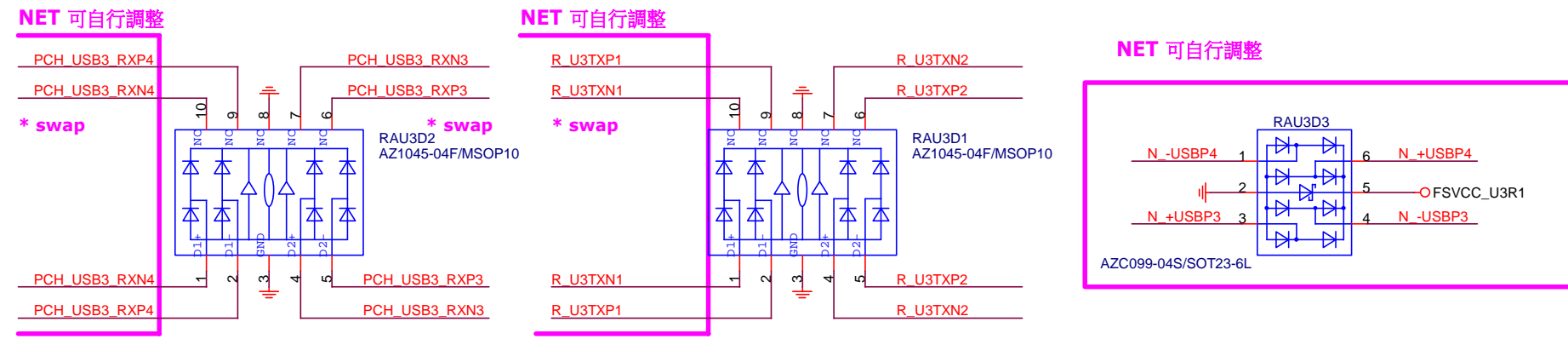

FUSE



| | | |
|--------------------------------|--|-------------------|
| Gigabyte Technology | | |
| Title R_USB30,USB_OC | | |
| Size Custom | Document Number GA-H110M-S2V | Rev 1.0 |
| Date: | Wednesday, March 09, 2016 | Sheet 34 of 47 |

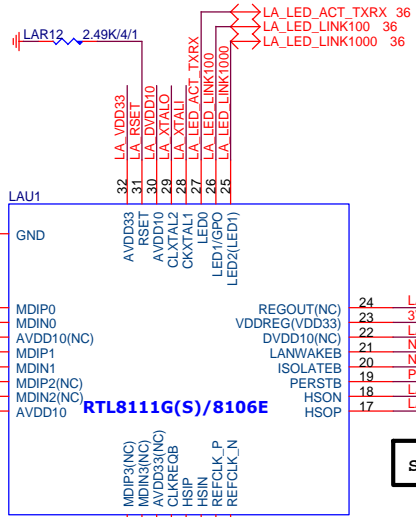

SRCLCK-->50歐姆:[18/4/10/4/18]

L1+CLK REQ# 節能:
需對應LA_SRCCLK LAN之CLKREQ#

LA_ML-->80歐姆:[15/5/5/5/15]

離IC近越好

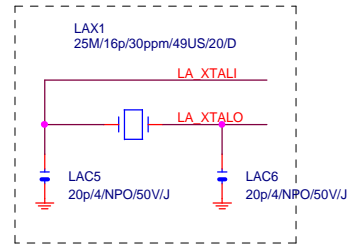

LAN POWER

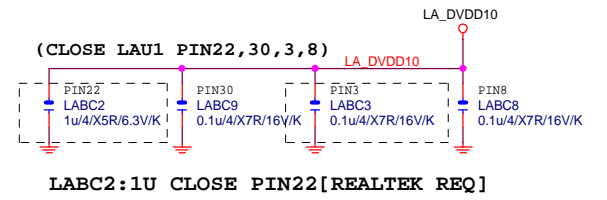

LAN POWER

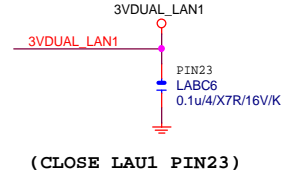

LAN POWER

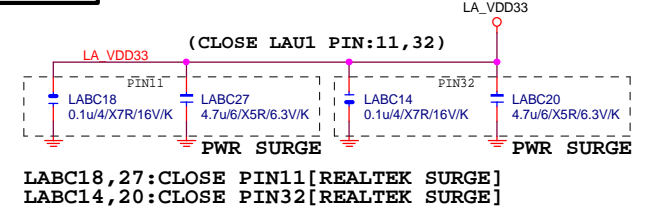

LAN POWER

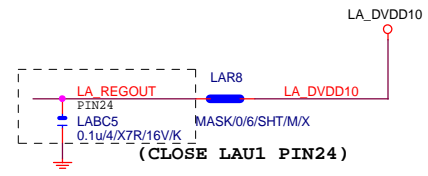

MDI ESD預留 *

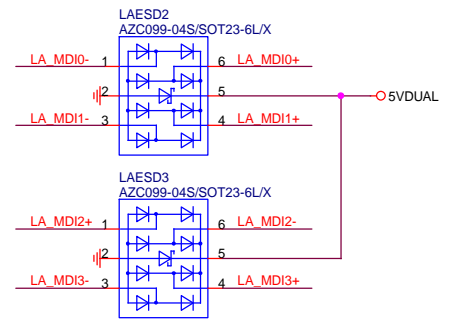

| | | |
|---------------------------------|-----------------|---------|
| Gigabyte Technology | | |
| Realtek RTL8111GUS | | |
| Size Custom | Document Number | Rev 1.0 |
| GA-H110M-S2V | | |
| Date: Wednesday, March 09, 2016 | Sheet 35 of 47 | |

USB_LAN CONNECTOR R1.06

USB_LAN CONNECTOR note:可變更USB NAME

RMA ESD PROTECT note:可變更USB NAME

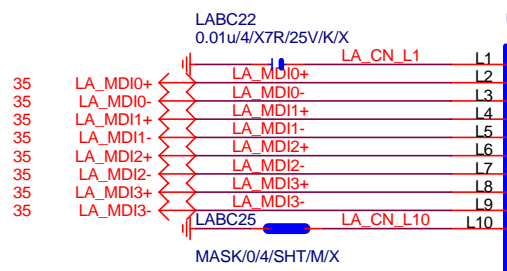
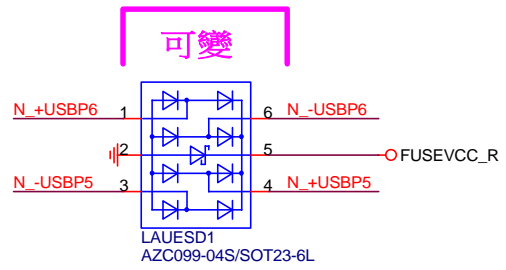

[RTL8111G]

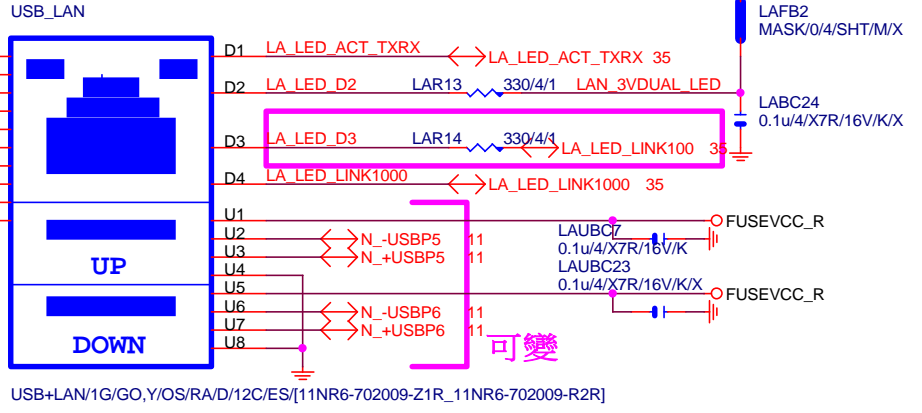

LA_MDI-->100歐姆:[20/4/8/4/20]

USB_LAN LAYOUT示意圖

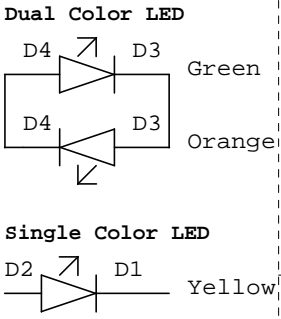
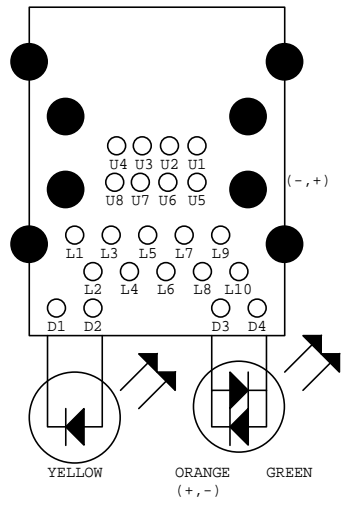

USB POWER note:可變更FUSE

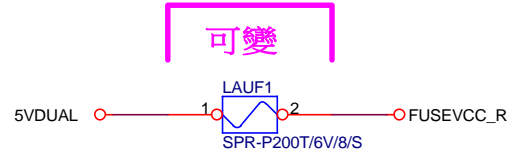

**Close to connector
USB_LAN 2-Port 2.0A
FUSE-0805**

EMI SHORT PAD

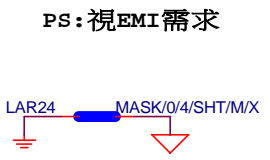

LAN POWER note: lan power連接及電流

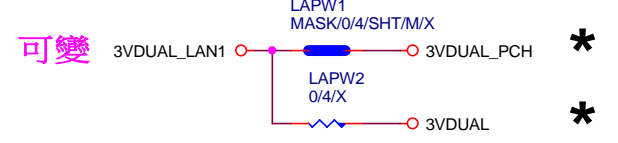

| | | |
|-------------------------------|---------------------------|----------------|
| Gigabyte Technology | | |
| LAN CONNECTOR-RTL8111G | | |
| Size | Document Number | Rev |
| Custom | GA-H110M-S2V | 1.0 |
| Date: | Wednesday, March 09, 2016 | Sheet 36 of 47 |

ALC887 三孔 AUDIO JACK

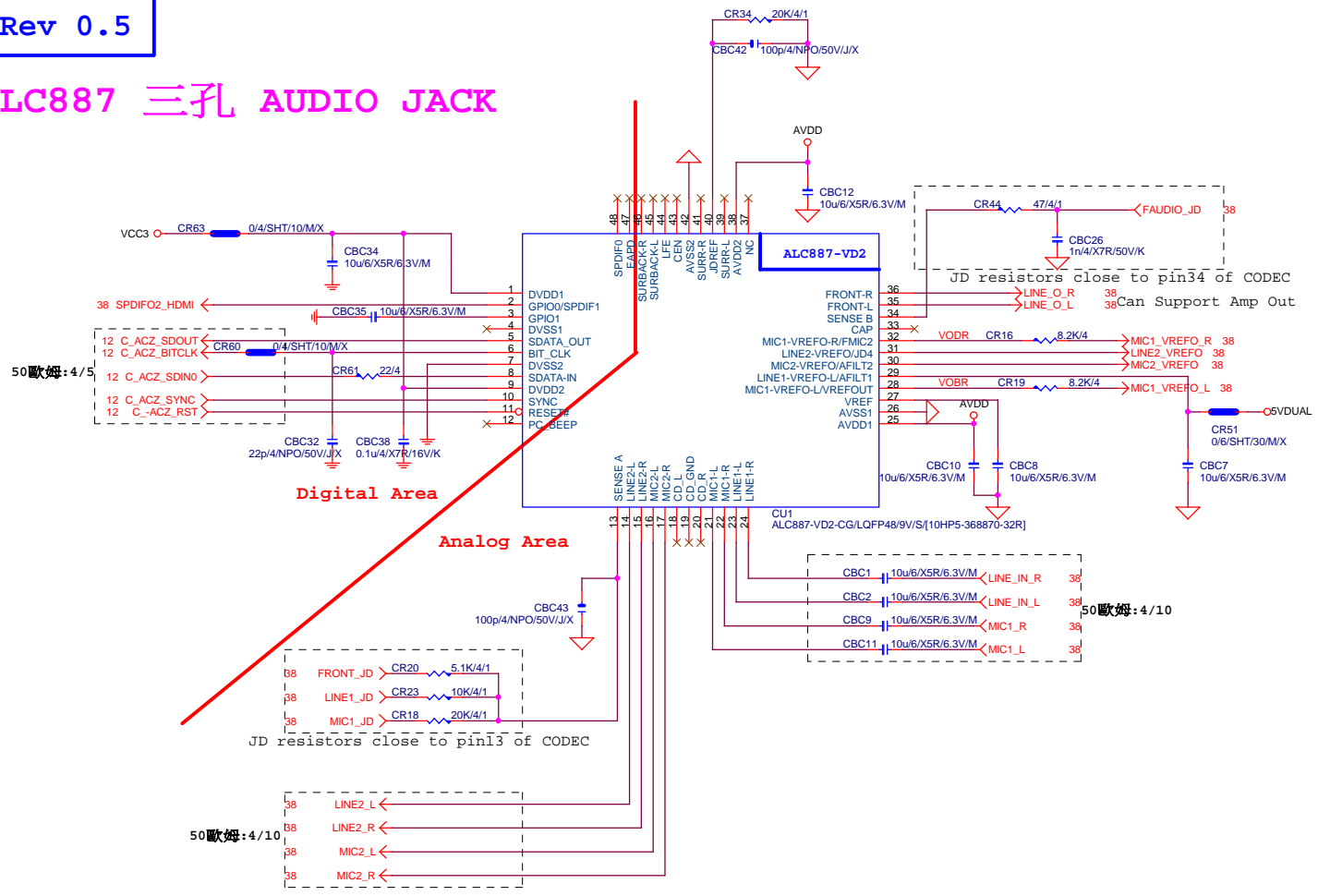

LAYOUT注意: 螺絲孔下GND方式

- MH1空間夠, 下DGND
空間不夠, 改為Isolate
- MH2一律改為Isolate

| | |
|-------|---------|
| ○ MH1 | MH2 ○ |
| DGND | Isolate |

Rev 0.5

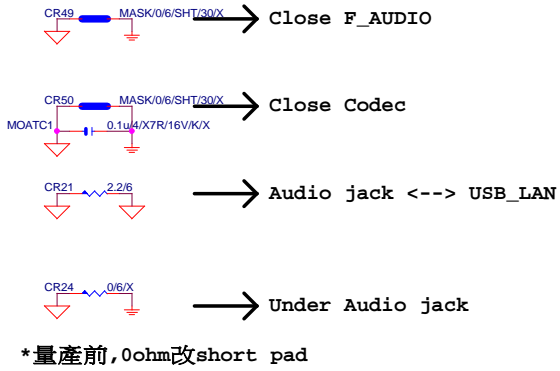

LINE-OUT

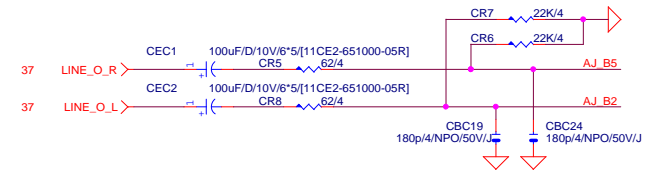

LINE-IN

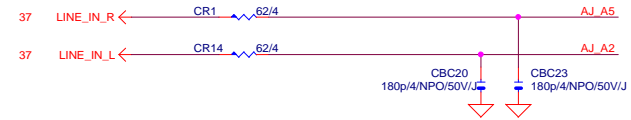

MIC-IN

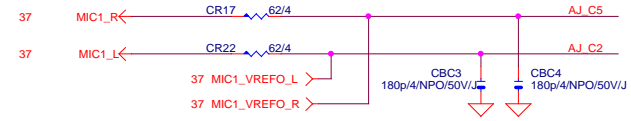

SURROUND

CEN/LFE

SURRBACK

SPDIF_OUT

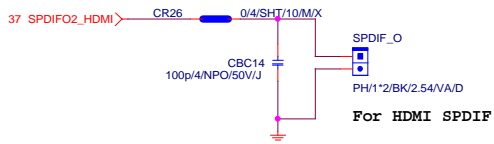

SPDIF_IN

AZALIA JACK

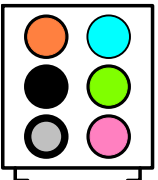

AZALIA JACK

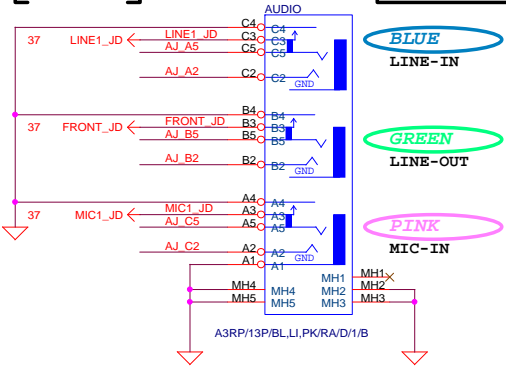

AZALIA FRONT PANEL

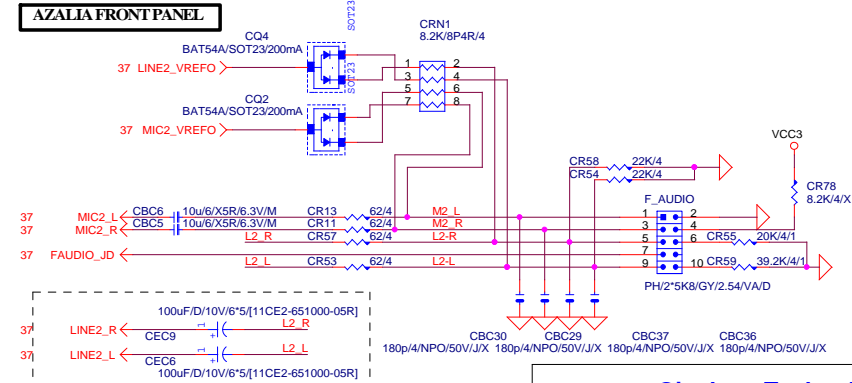

| | | | |
|----------------------------|---------------------------|---------------------|----------|
| Gigabyte Technology | | | |
| AUDIO JACK | | | |
| Title | | Rev 1.0 | |
| Size | Document Number | GA-H110M-S2V | |
| Custom | | | |
| Date: | Wednesday, March 09, 2016 | Sheet | 38 of 47 |

Front USB3.0

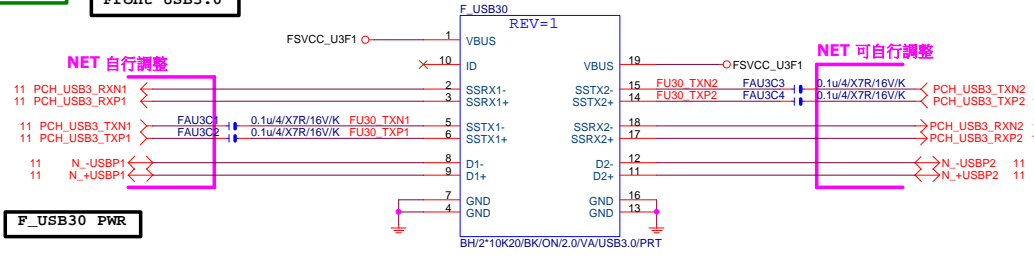

F_USB30 PWR

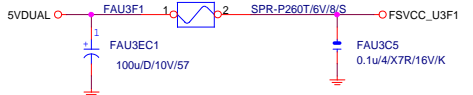

刪除U30C3

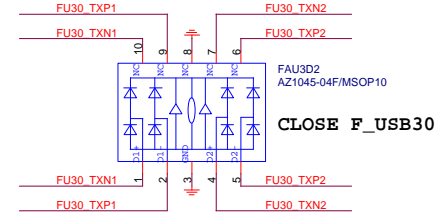
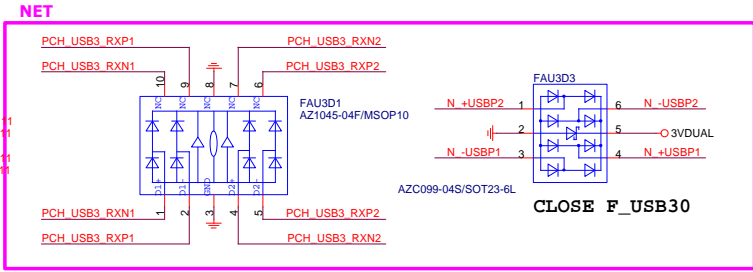

-USBOC_F

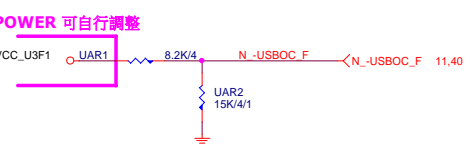

-USBOC_R

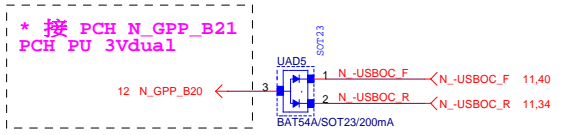
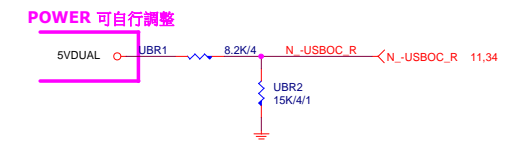

| | | |
|--------------------------------------|-------------------------------------|----------------|
| Gigabyte Technology | | |
| Title R_USB30,F_USB30, USB_OC | | |
| Size Custom | Document Number GA-H110M-S2V | Rev 1.0 |
| Date: Wednesday, March 09, 2016 | Sheet 39 | of 47 |

NET 可變

FUSB2X5-HS

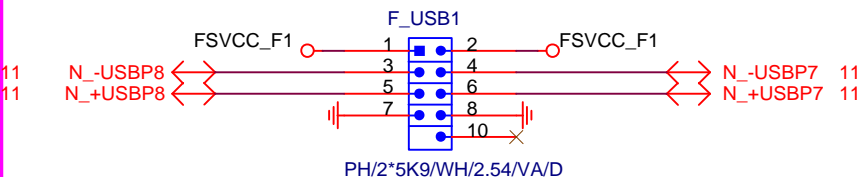

PH/2*5K9/WH/2.54/VA/D

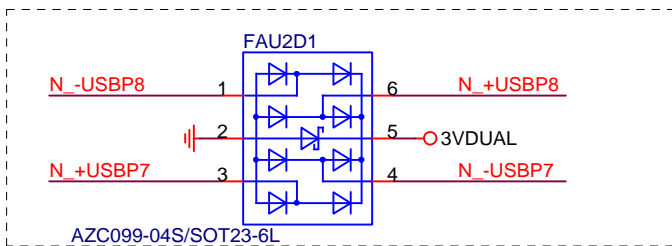

Close to connector

FUSE 2 Port 1 Fuse 2A

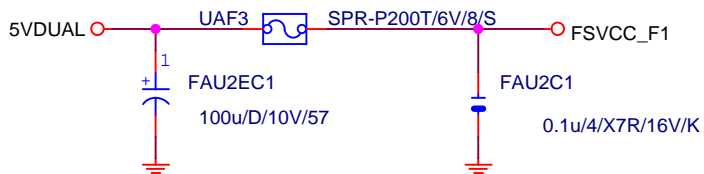

NET 可變

FUSB2X5-HS

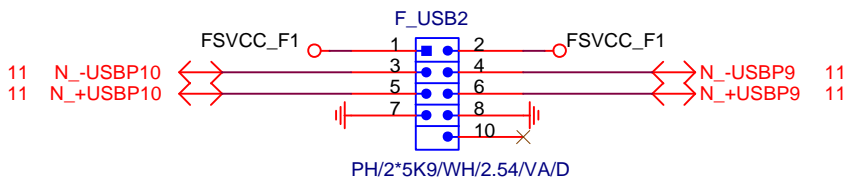

PH/2*5K9/WH/2.54/VA/D

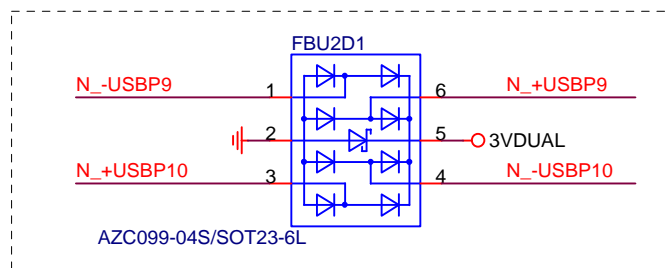

Close to connector

FUSE 2 Port 1 Fuse 2A

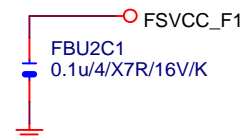

F_USB 2.0 OC SIGNAL

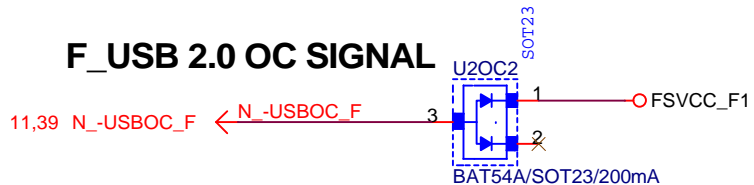

Gigabyte Technology

| | | |
|--------|---------------------------|----------------|
| Title | | |
| USB2.0 | | |
| Size A | Document Number | Rev |
| | GA-H110M-S2V | 1.0 |
| Date: | Wednesday, March 09, 2016 | Sheet 40 of 47 |

COM PORT

Rev: 0.7

COM PORT

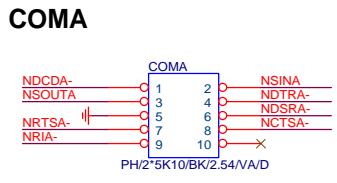
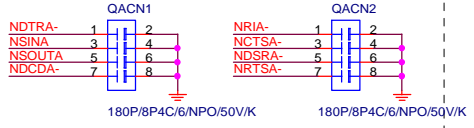
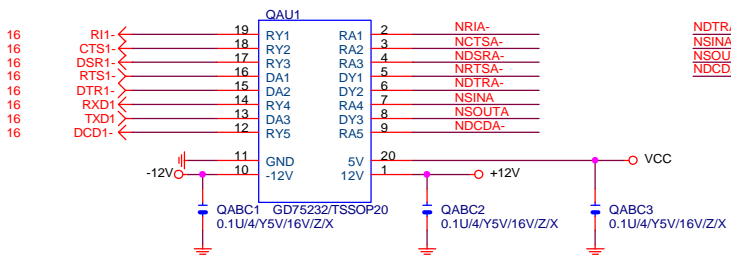

COM R.I

LPT PORT

TPM CONNECT

Thunderbolt (N/A)

FRONT PANEL SHORT

Rev: 0.7

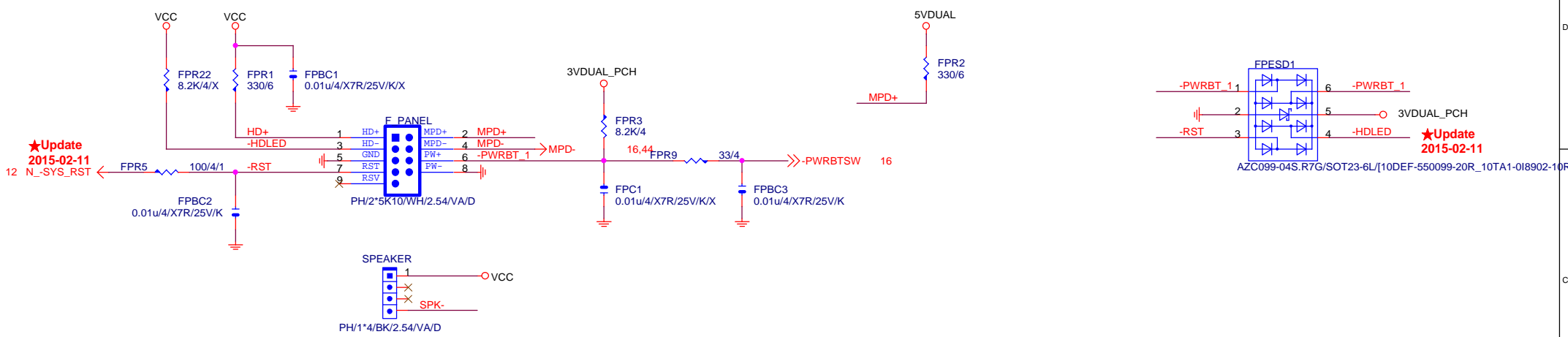

★Update 2015-02-11

★Update 2015-02-11

CASE OPEN

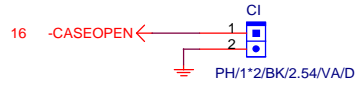
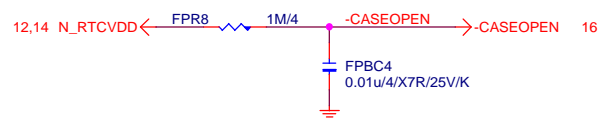

SATA LED

★Update 2015-02-12

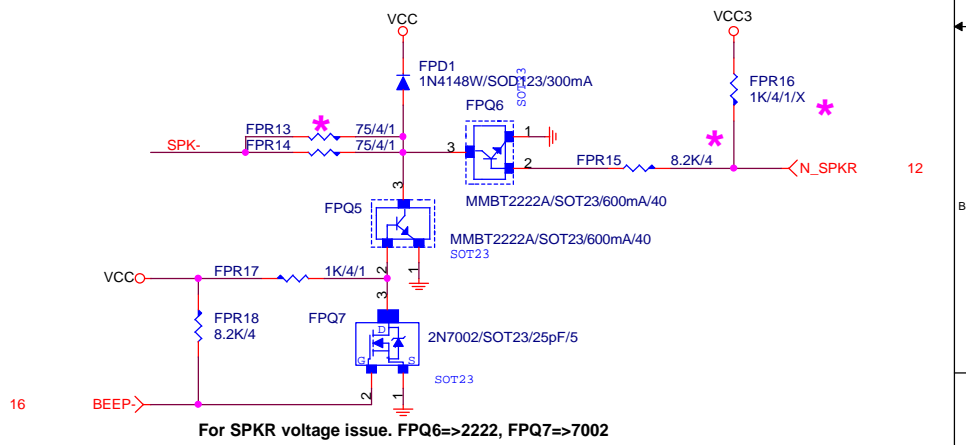

| | | | |
|----------------------------|---------------------------|---------------------|----------------|
| Gigabyte Technology | | | |
| FRONT PANEL | | | |
| Size Custom | Document Number | GA-H110M-S2V | |
| Date: | Wednesday, March 09, 2016 | Sheet | 42 of 47 |
| | | | Rev 1.0 |

DVI Rev: 0.51

DVI: 20/4/6/4/20
Impedance=85 +- 17.5%

NET 可變

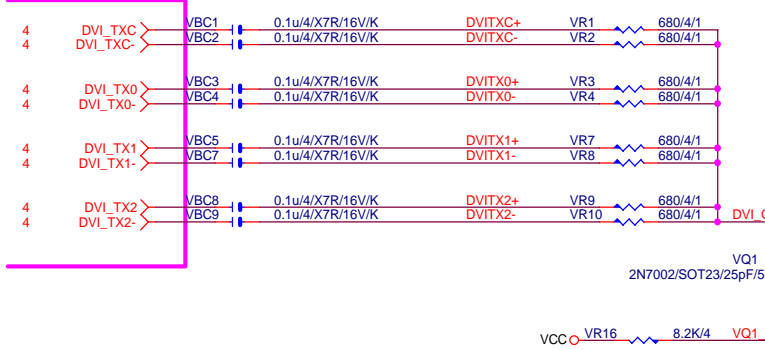

DVI PU

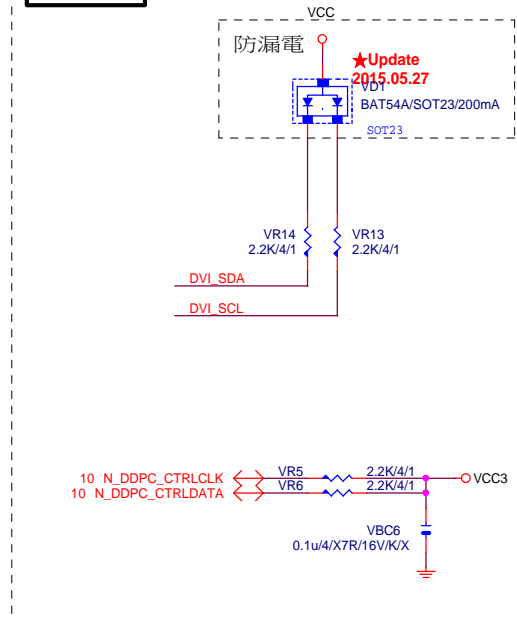

DVI CONN

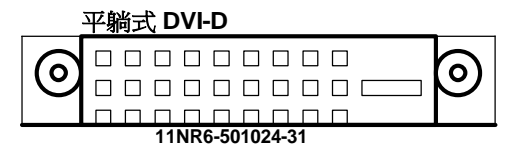
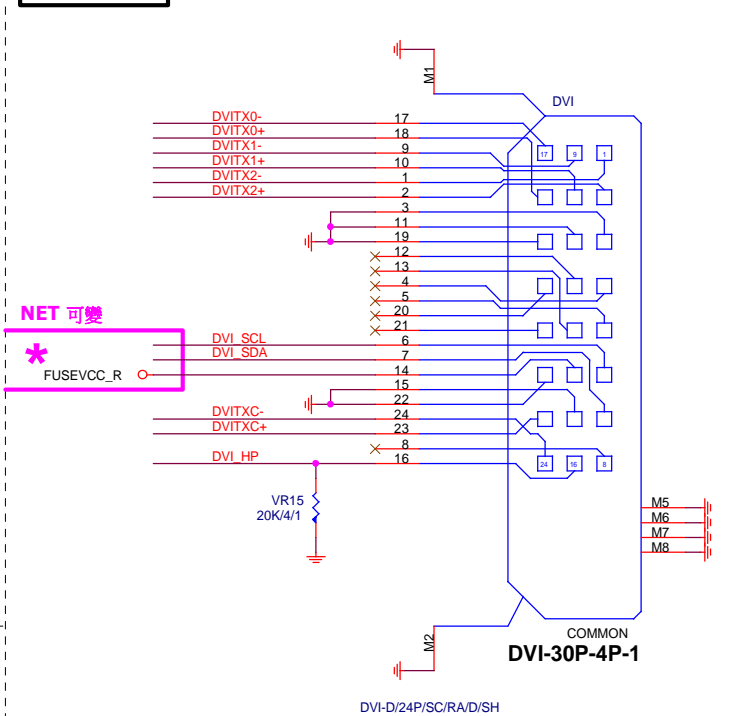

ESD

NET 可變

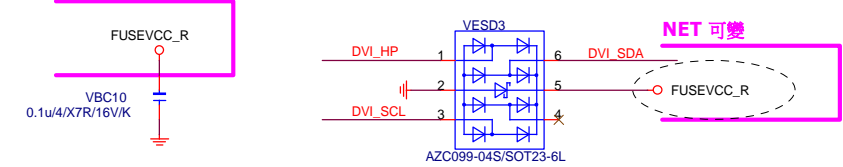

Close to connector

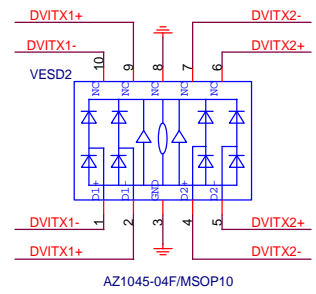

Close to connector

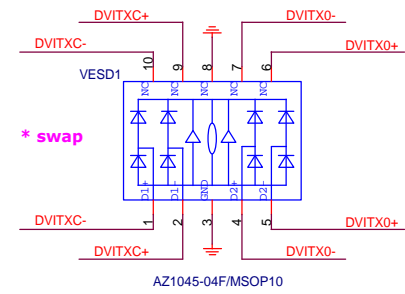

Close to connector

| | | | |
|----------------------------|---------------------------|---------------------|----------|
| Gigabyte Technology | | | |
| Title | | | |
| DVI | | | |
| Size Custom | Document Number | GA-H110M-S2V | |
| Date: | Wednesday, March 09, 2016 | Sheet | 43 of 47 |
| | 2 | | 1 |

Rev 1.0

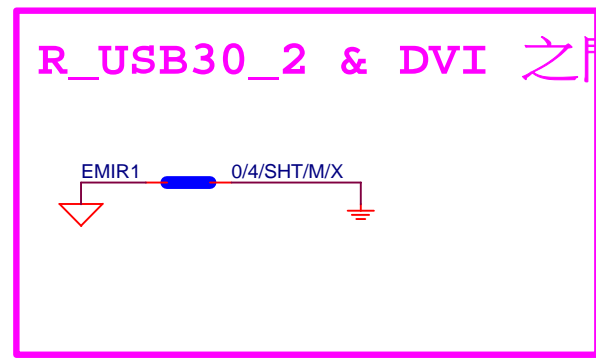
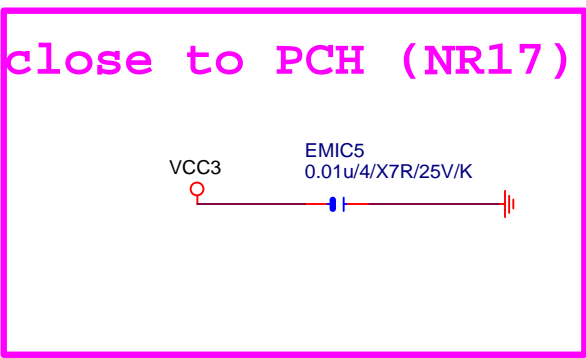
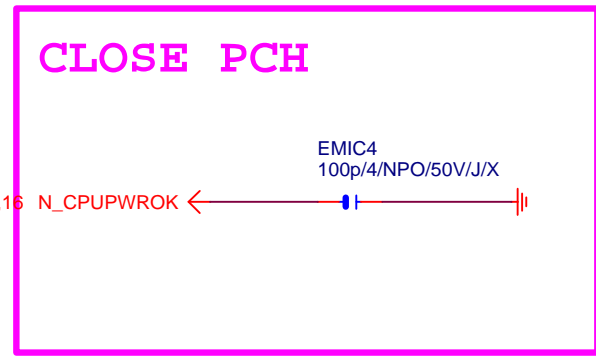
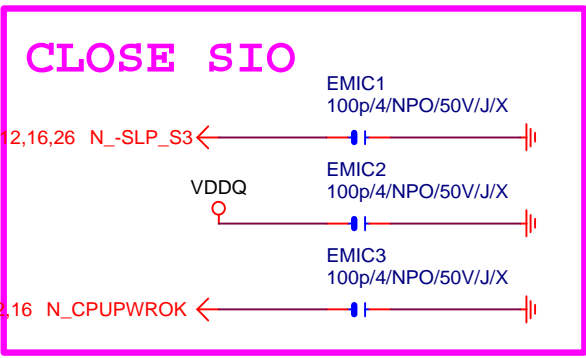

GIGABYTE™

Title: **EMI/ESD**

| | | |
|---------------------------------|--|-------------------|
| Size A | Document Number GA-H110M-S2V | Rev 1.0 |
| Date: Wednesday, March 09, 2016 | Sheet 44 of 47 | |

POWER BLOCK MAP

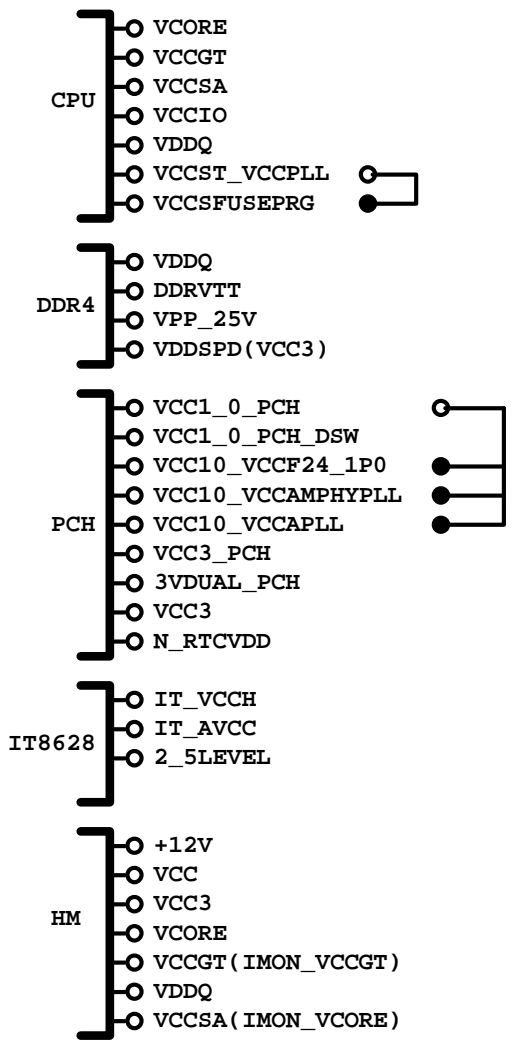

VCORE/VCCGT

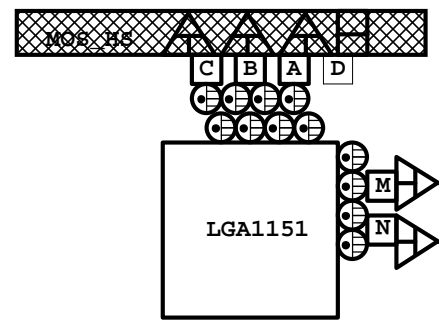
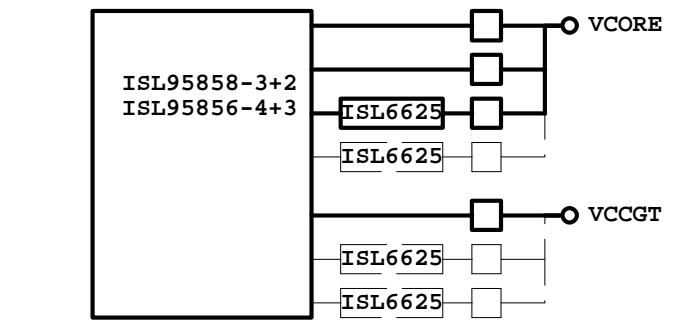

POWER

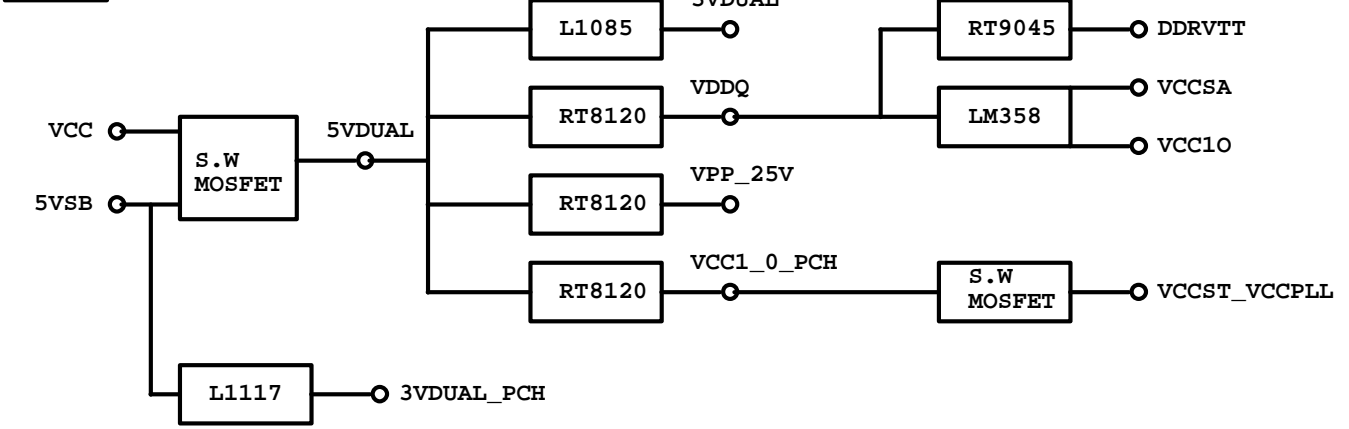

FUSE POWER F/R

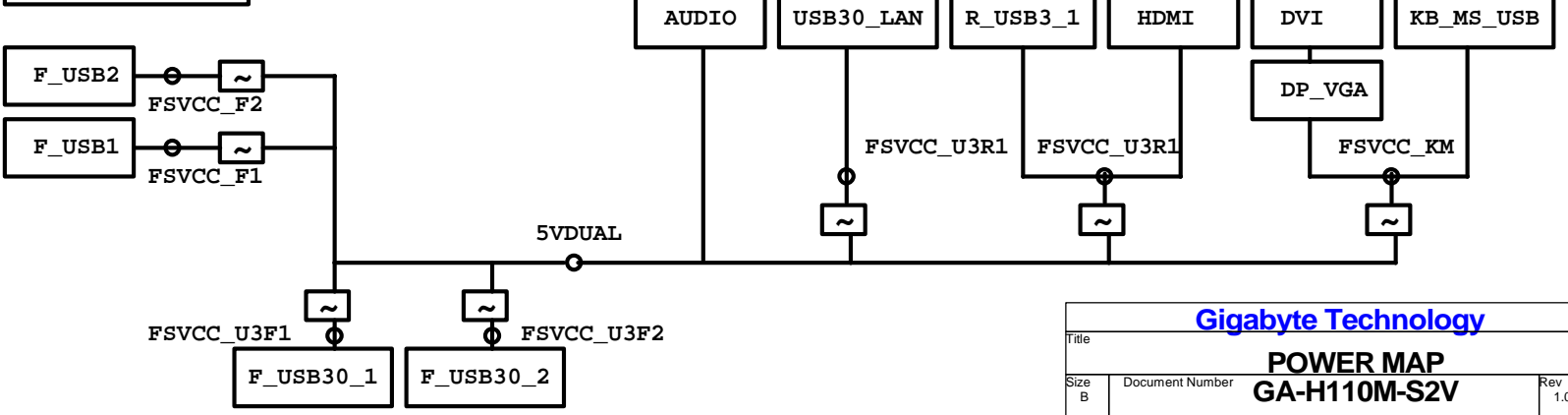

| | | | |
|----------------------------|---------------------------|------------|----------|
| Gigabyte Technology | | | |
| POWER MAP | | | |
| GA-H110M-S2V | | | |
| Size B | Document Number | Rev 1.0 | |
| Date: | Wednesday, March 09, 2016 | Sheet | 45 of 47 |

固態電容料號.請自行修改

| 日系黑色固態 | Capture Value |
|------------------|-------------------------|
| 11C02-C85600-01R | 560u/FP/D/6.3V/68/C/8m |
| 11C05-C82700-01R | 270u/FP/D/16V/88/C/12m |
| 11C05-C61000-01R | 100u/OS/D/16V/66/C/30m |
| 11C02-C51000-01R | 100u/FP/D/6.3V/65/C/13m |

| 日系一般固態 | Capture Value |
|------------------|-----------------------|
| 11C02-685600-01R | 560u/FP/D/6.3V/68/8m |
| 11C05-882700-01R | 270u/FP/D/16V/88/12m |
| 11C05-661000-03R | 100u/OS/D/16V/66/30m |
| 11C02-651000-02R | 100u/OS/D/6.3V/66/30m |

| 台系固態 | Capture Value |
|------------------|-------------------------|
| 11C02-661000-09R | 100u/OS/D/6.3V/66/A/35m |
| 11C05-691000-09R | 100u/OS/D/16V/69/A/35m |
| 11C05-8C2700-09R | 270u/FP/D/16V/8C/A/10m |
| 11C02-695600-09R | 560u/FP/D/6.3V/69/A/11m |

IRON CHOKE

| | 料號 | Capture Value | SIZE | Footprint |
|-----|------------------|-----------------------|-------|--------------------|
| DIP | 11LC5-M4500C-01R | 0.5uH/40A/IMD109/M/D | 10*10 | CHOKE05U-40A-1PQ-3 |
| DIP | 11LC5-M2500C-01R | 0.5uH/20A/IMD0809/M/D | 8*8 | CHOKE1U-R50M-IF |

Ferrite

| | 料號 | Capture Value | SIZE | Footprint |
|-----|------------------------|-------------------------|-------|--------------------|
| DIP | 11LC5-F3500C-11R | 0.5uH/32A/INCG109/FSI/D | 10*10 | CHOKE05U-40A-1PQ-3 |
| DIP | 11LC5-F2500C-11R | 0.5uH/25A/INC0809/F/D | 8*8 | CHOKE1U-R50M-IF |
| SMD | 未建(SIUC1007-R30M-JJLW) | | 10*7 | CHOKE11X8MM-SMD |

BEAD

| | 料號 | Capture Value | SIZE | Footprint |
|-----|------------------|---------------|------|-----------------|
| DIP | 10LFB-15470A-01R | 47/4030/15A/S | 4*3 | BEADC8B-BPH_SMD |

PWM料號

| | | 料號 | Capture Value | Footprint |
|-----|----------|------------------|---------------|-------------------|
| PWM | ISL95856 | 10TA1-695856-01R | | IC52QFN-6x6-G |
| PWM | ISL95858 | 10TA1-695858-01R | | IC52QFN-6x6-G |
| PWM | IR35201 | 10TA1-635201-00R | | IC56QFN-9VRS4339 |
| PWM | IR3570 | 10TA1-603570-00R | | IC40MLFP-ISL95835 |

GIGABYTE™

| | | | | | |
|--------|---------------------------|-------|--------------------------|----|------------|
| Title | | | RT8120_DDR4 POWER | | |
| Size | Document Number | | | | Rev |
| Custom | GA-H110M-S2V | | | | 1.0 |
| Date: | Wednesday, March 09, 2016 | Sheet | 46 | of | 47 |

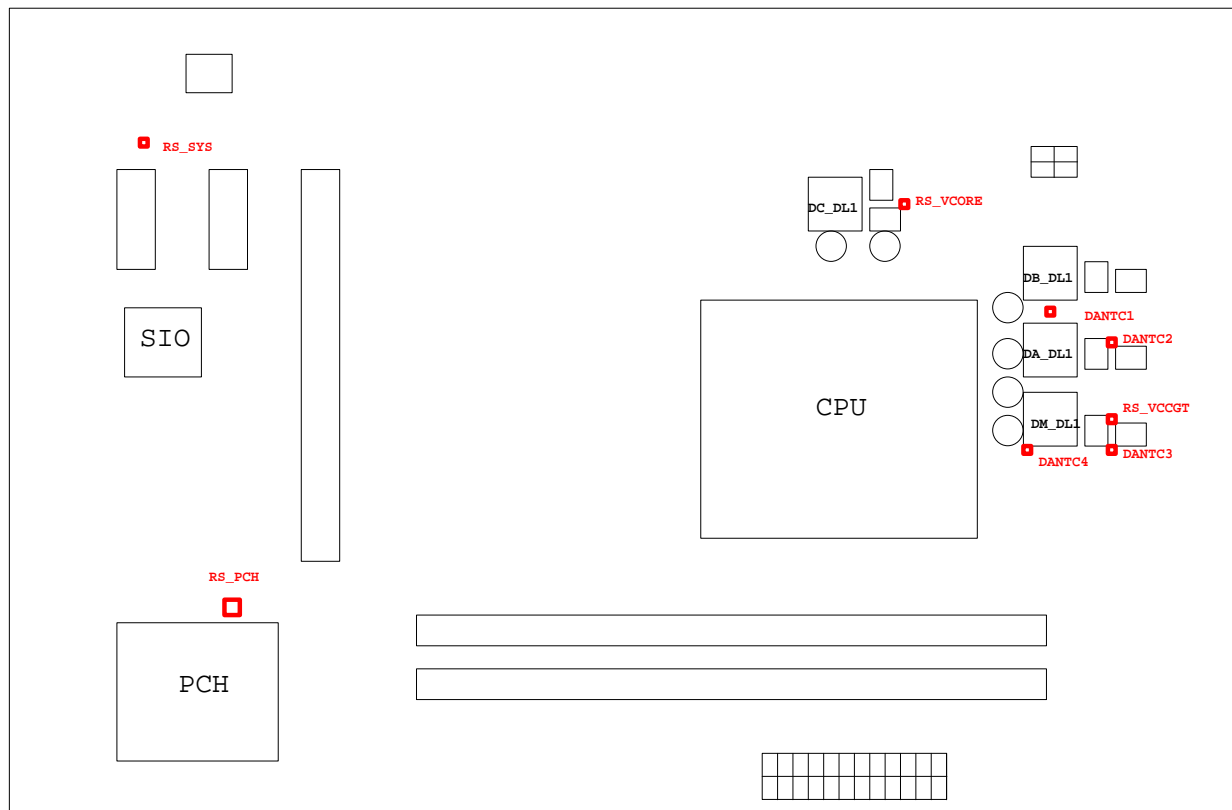

| 熱敏電阻 | 擺放靠近位置 | 走線方式 |
|----------|--------|--------------|
| DANTC4 | DM_DL1 | Differential |
| DANTC1 | DA_DL1 | Differential |
| DANTC3 | DM_DQ1 | Differential |
| DANTC2 | DA_DQ1 | Differential |
| RS_VCORE | DA_DQ1 | N/A |
| RS_VCCGT | DM_DQ1 | N/A |
| RS_PCH | PCH | N/A |
| RS_SYS | CU1 | N/A |