

Model Name: GA-H81M-DS2

Revision 2.0

SHEET TITLE

01	COVER SHEET
02	BOM & PCB MODIFY HISTORY
03	BLOCK DIAGRAM
04	CPU_LGA1150-A
05	CPU_LGA1150-B
06	CPU_LGA1150-C
07	DDR III CHANNEL A
08	DDR III CHANNEL B
09	PCH_FDI,DMI,USB,PCIE,NVRAM
10	PCH_DP,CLK BUFFER
11	PCH_HOST,SATA,PCI
12	PCH_GPIO,CTRL,AUDIO
13	PCH_PWR,GND
14	PCI EXPRESS*16 SLOT
15	PCI EXPRESS X1 *2 SLOT
16	ITE 8620 LPC IO
17	COM,KB_MS_USB,USB30_20
18	HWM,FAN CTRL,OV,-PROCHOT
19	DUAL BIOS
20	FP,FUSB,SPK,SATALED
21	Realtek ALC887-VD2
22	REAR AUDIO JACK
23	REALTEK RTL8111F
24	DISCRETE POWER
25	ATX , CLOCK GEN
26	VCORE ISL95812_1
27	VCORE ISL95812_2

SHEET TITLE

28	RT8120_DDR POWER
29	LPT

Gigabyte Technology

Title		
Cover Sheet		
Size	Document Number	Rev
Custom	GA-H81M-DS2	2.0
Date:	Monday, October 14, 2013	Sheet 1 of 29

BLOCK DIAGRAM

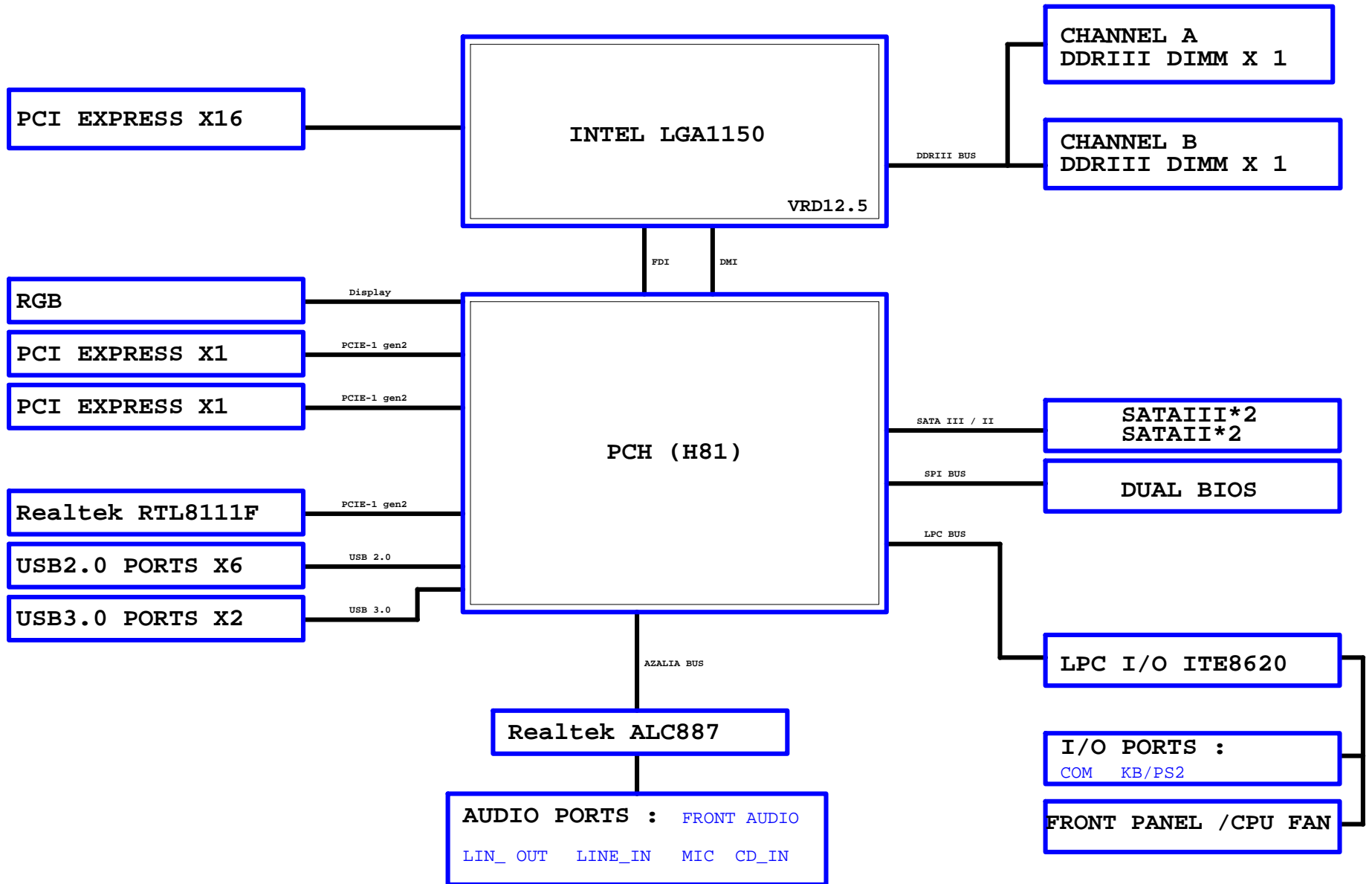

LGA1150 (E)

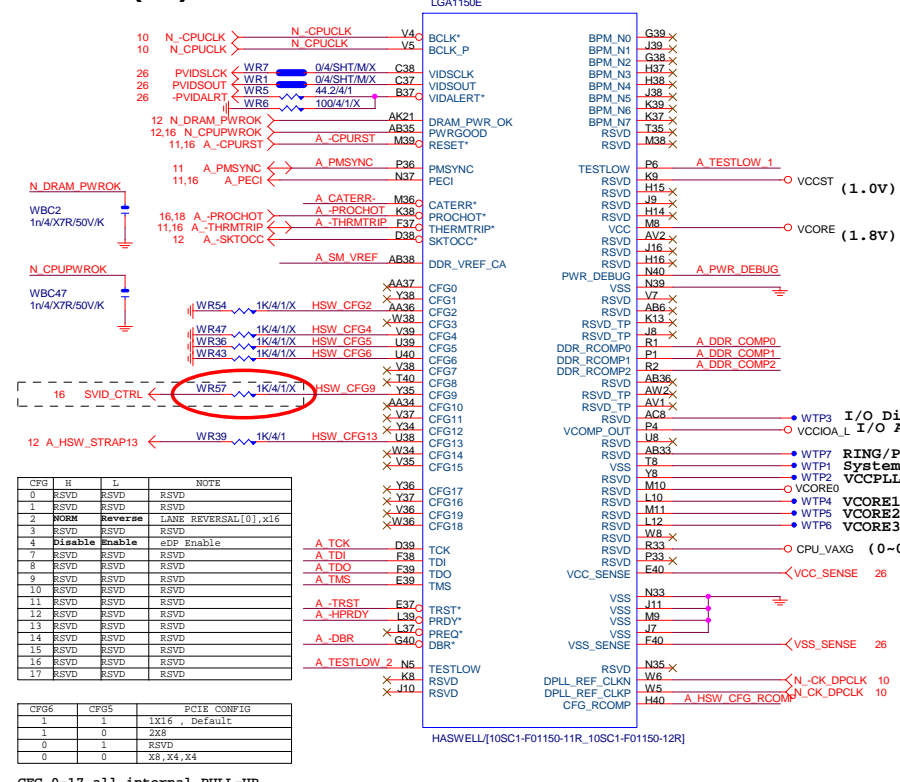

LGA1150 (D)

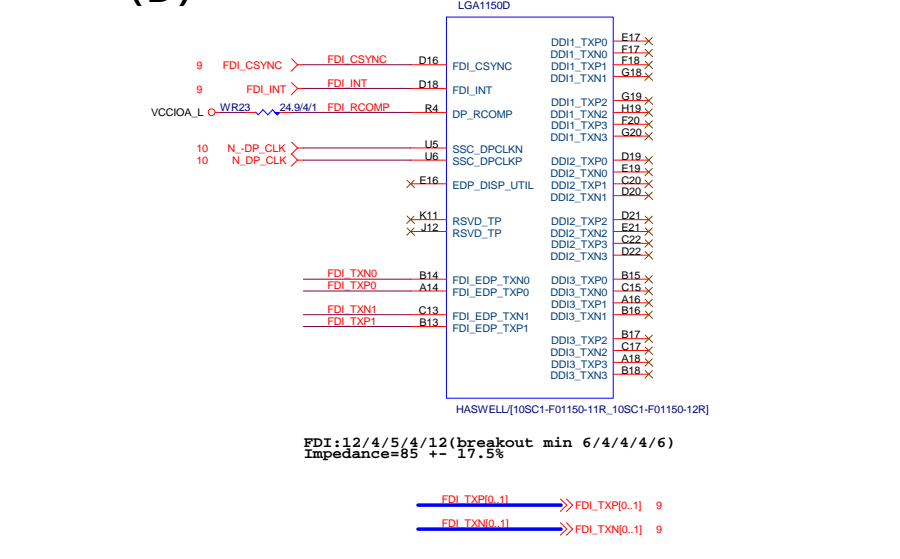

LGA1155 (C)

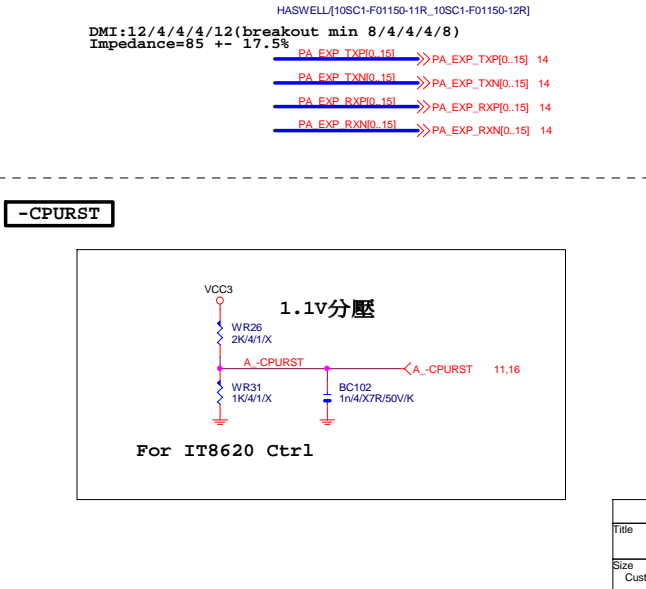
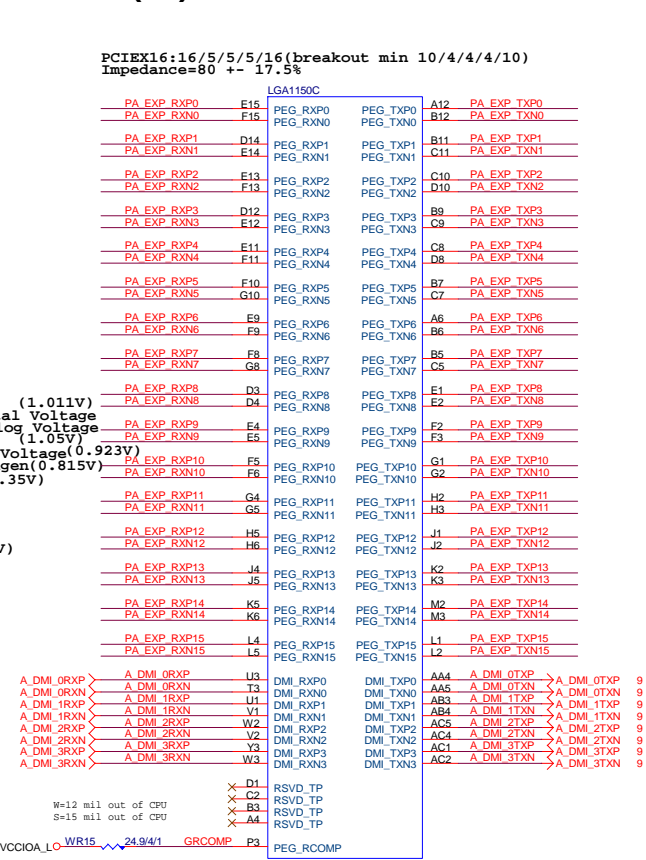

CPU SVID

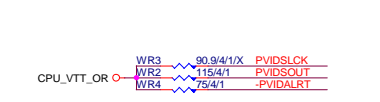

CPU PU/PD

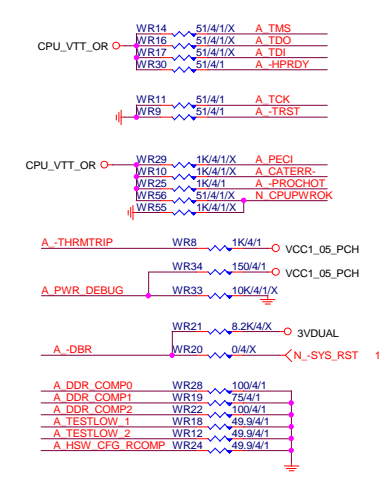

SM REF

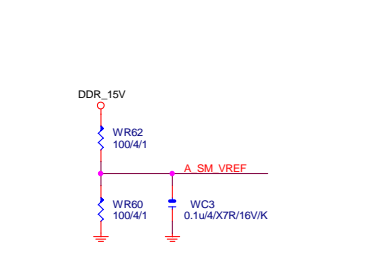

Gigabyte Technology

LGA1150 (F, J)

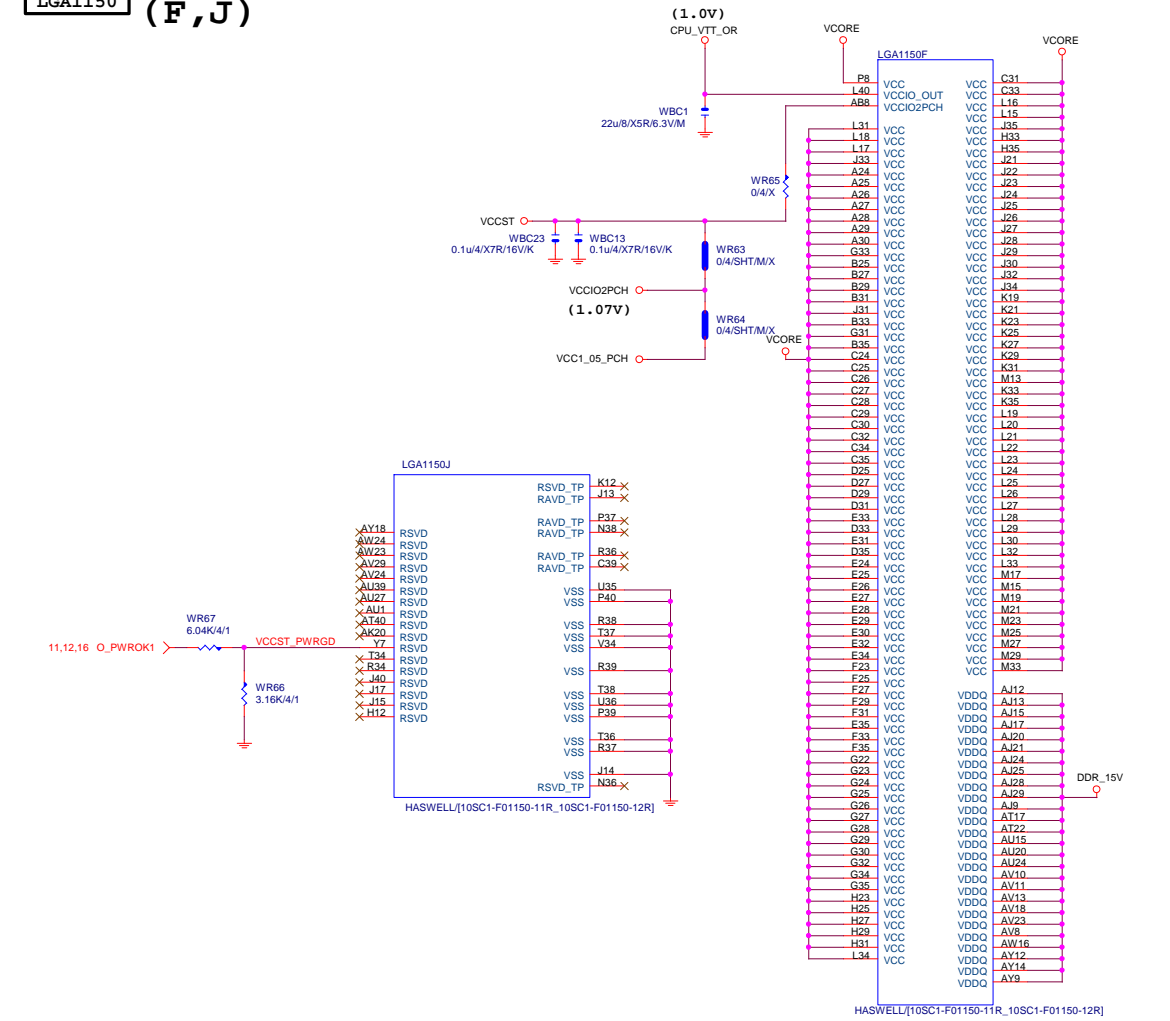

LGA1155 (G, H, I)

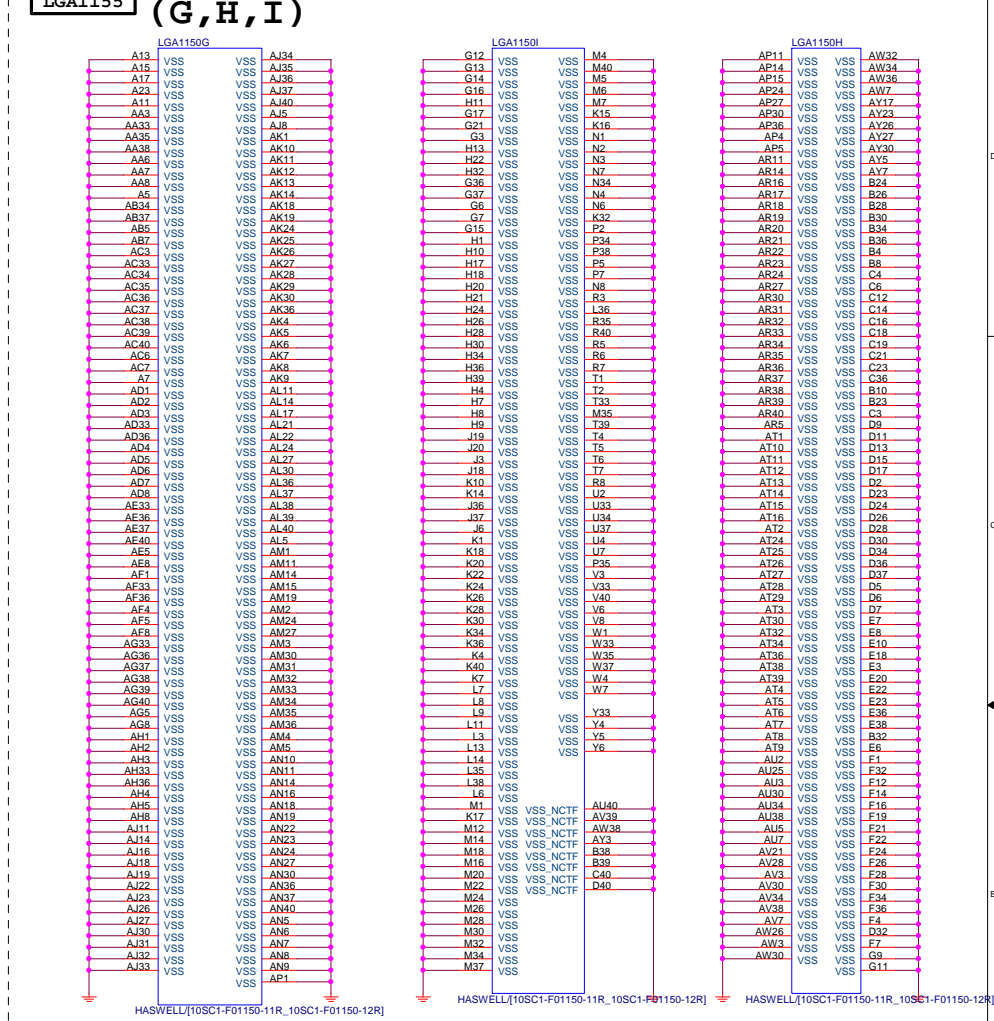

VCore CAP

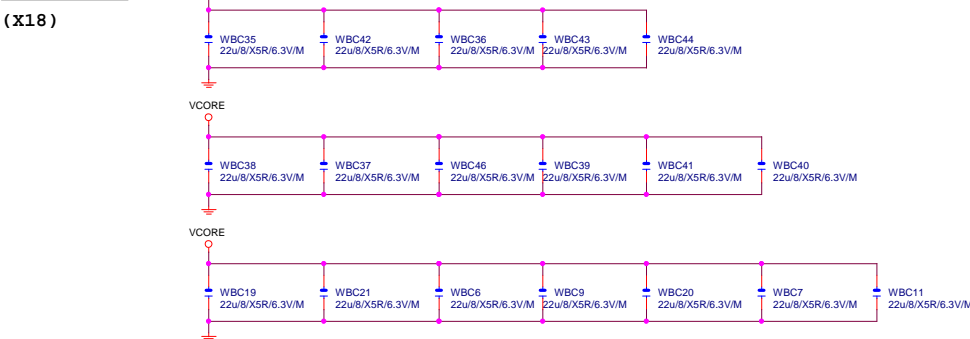

DDR CAP

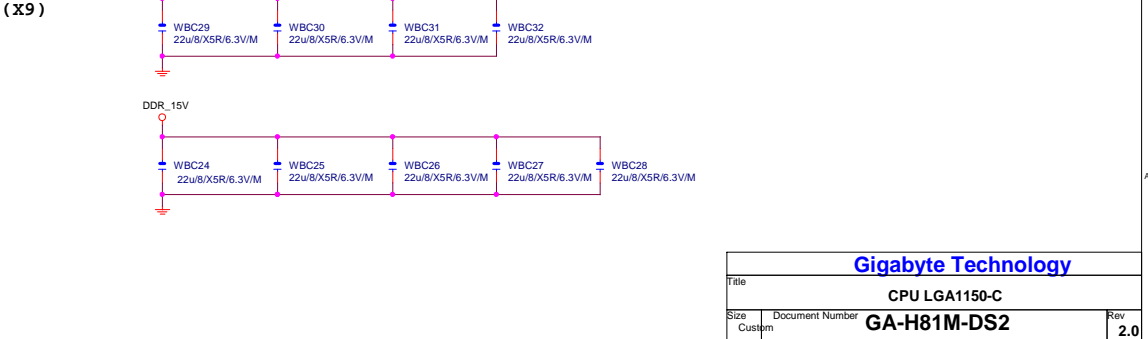

Gigabyte Technology

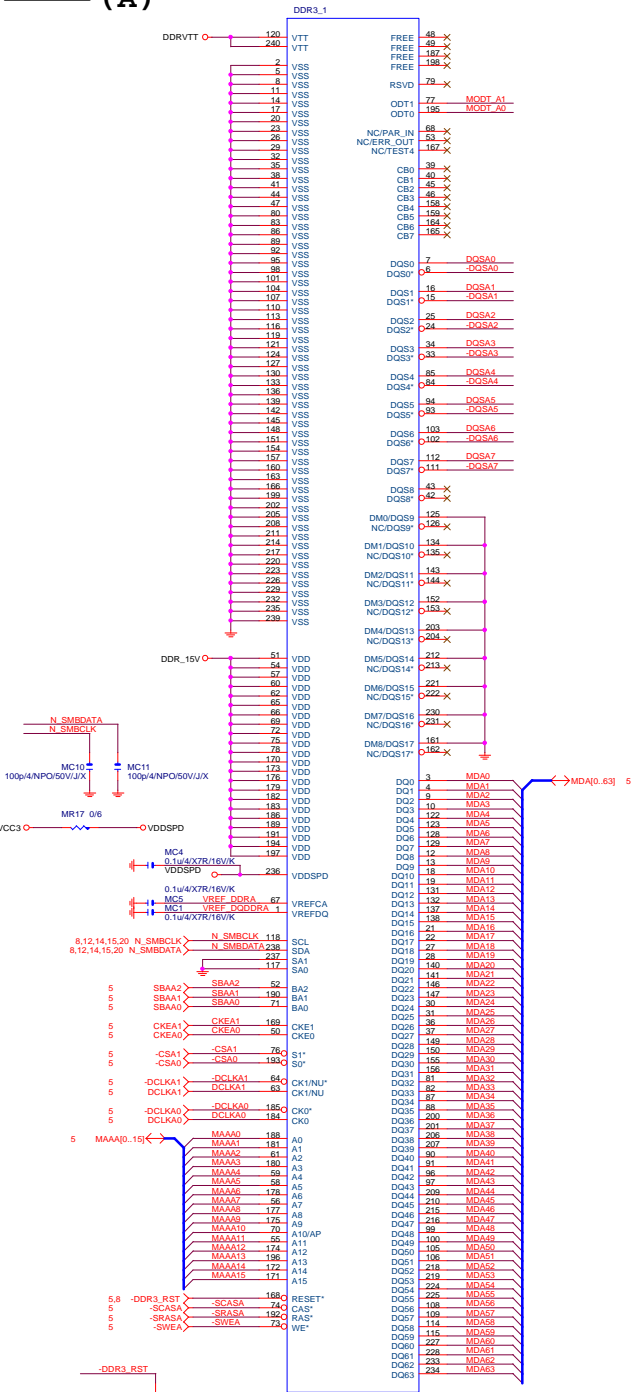

DDR3 (B)

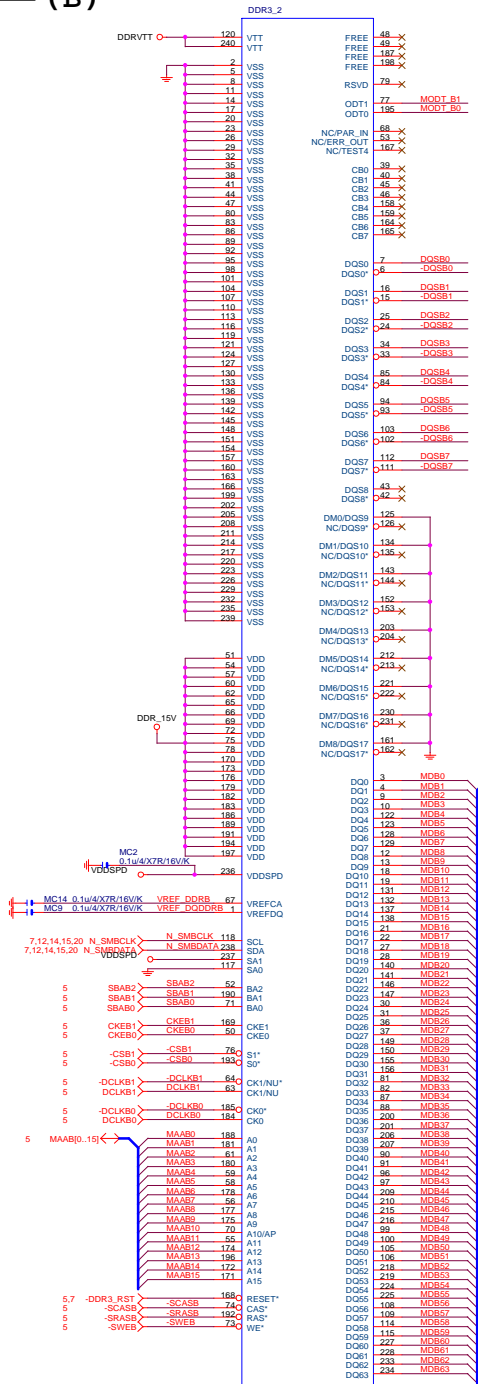

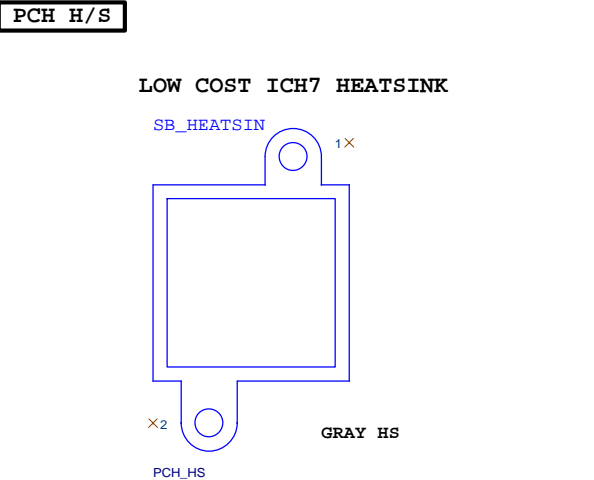
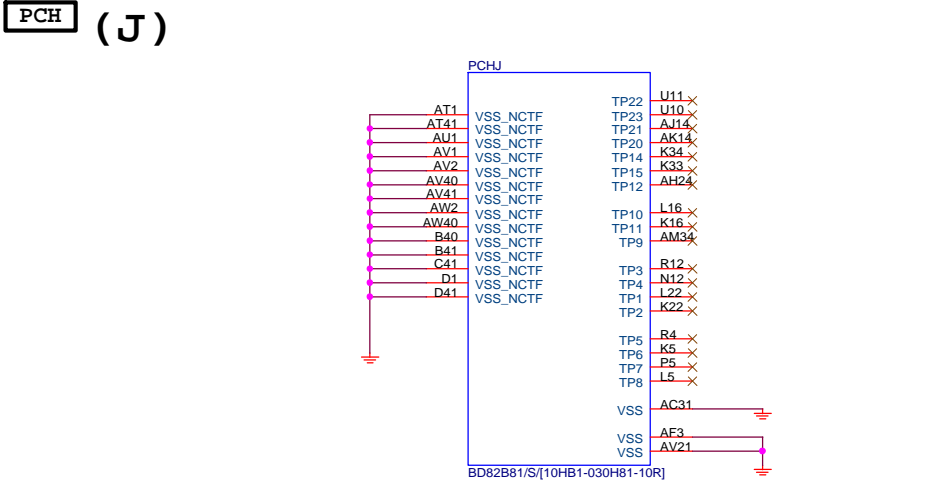
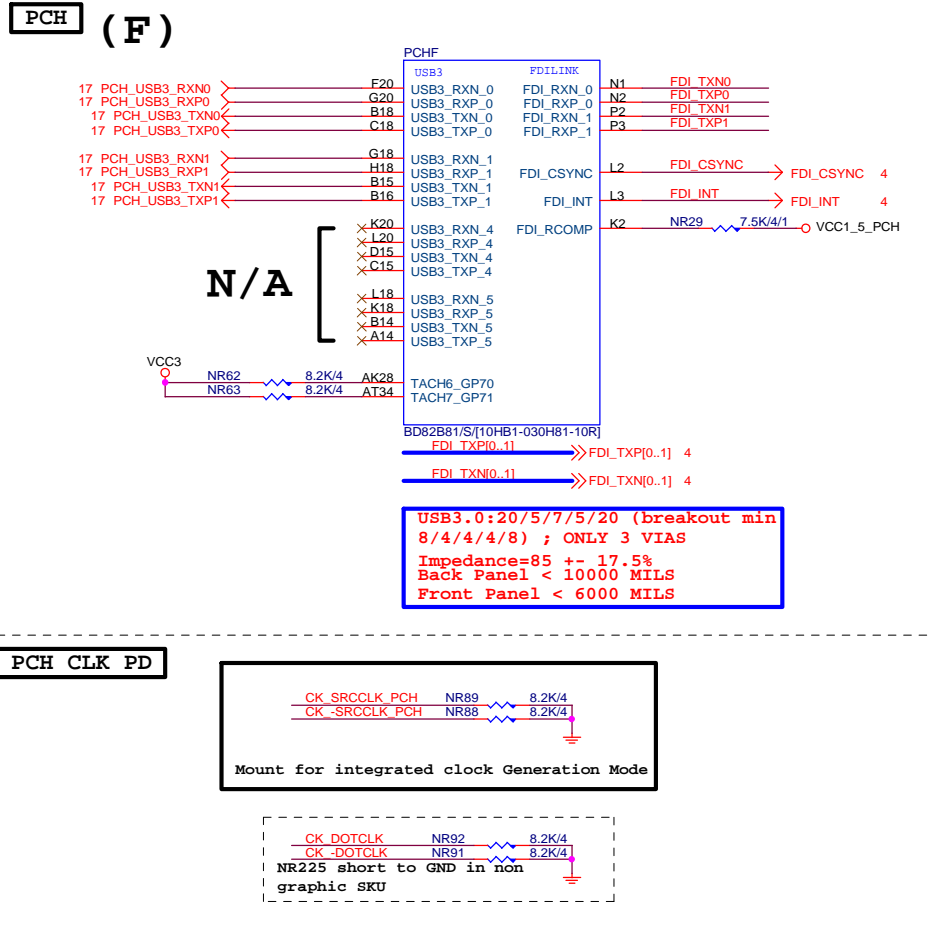
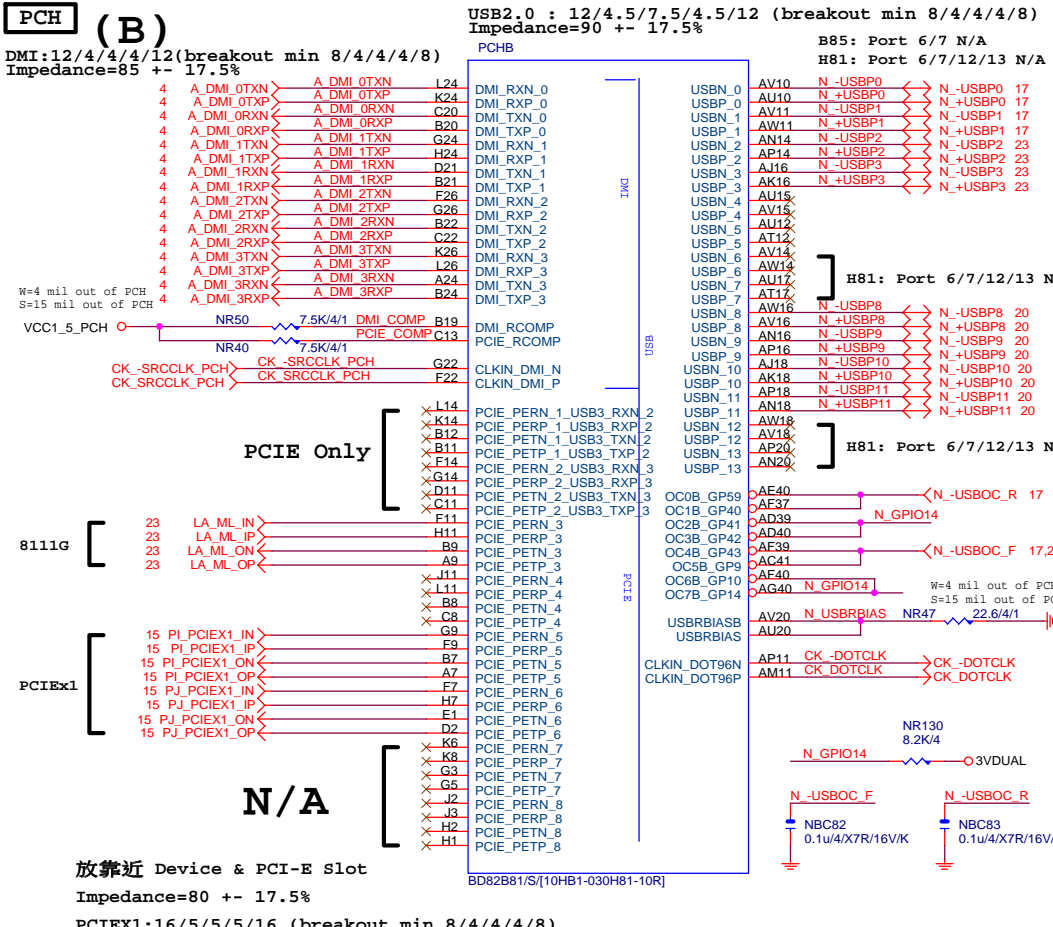

USB TABLE

OC[3:0]# for Device 29 (ports 0-7)
OC[7:4]# for Device 26 (ports 8-13)

USB OC#	Configure
OC0#	R_USB30
OC1#	USB_LAN
OC2#	Not Use
OC3#	N/A
OC4#	F_USB1
OC5#	F_USB2
OC6#	Not Use
OC7#	N/A

PCH (H)

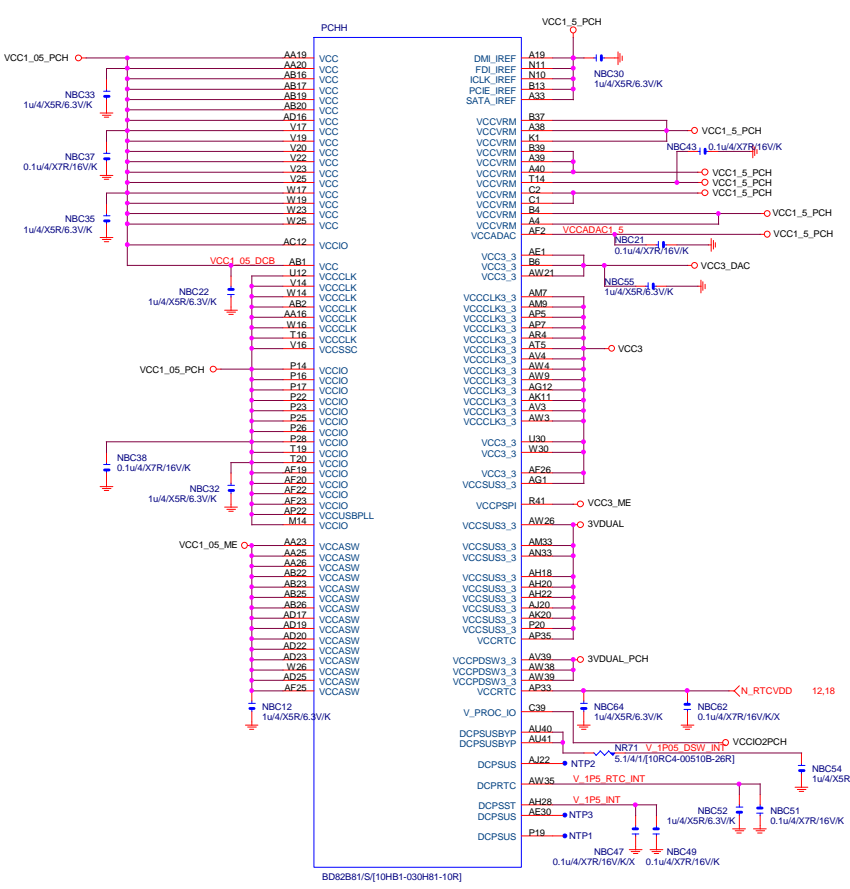

VCC3_DAC

CLOSE北橋(注意震盪水波紋)

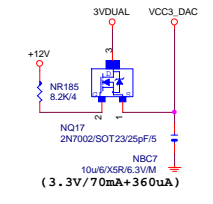

3VDUAL_PCH

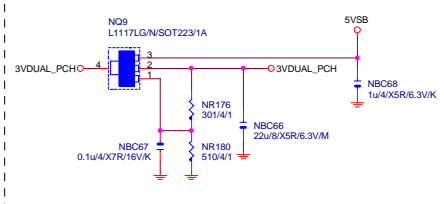

SHT_PWR



CAP

(3.3V) (X6)

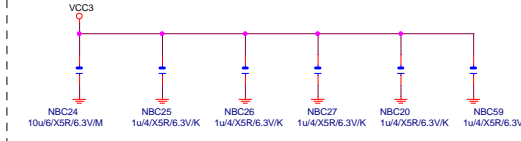

(1.05V) (X5)

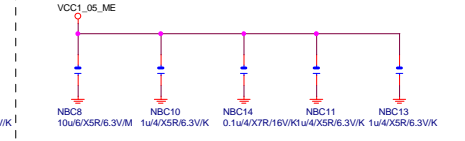

(1.05V) (X6)

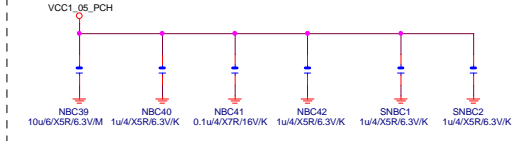

(1.05V) (X2) (3.3V) (X2)

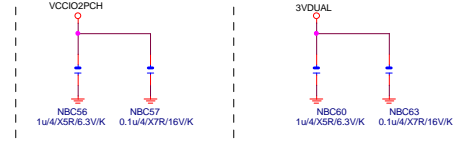

(1.05V) (X10)

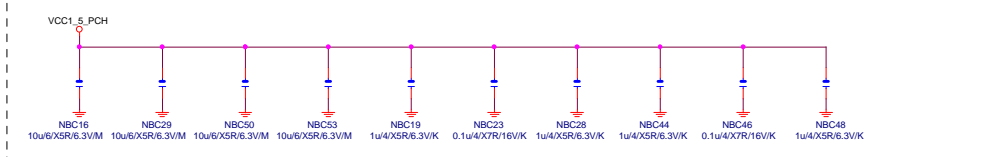

PCH (I)

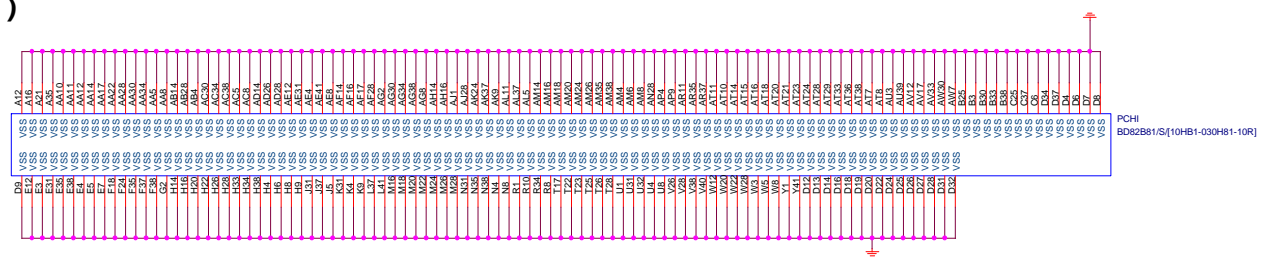

PCIEX16 CAP

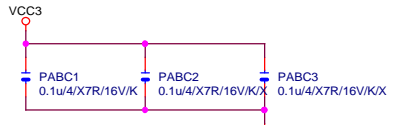

PCIEX16 PROTECT SHT

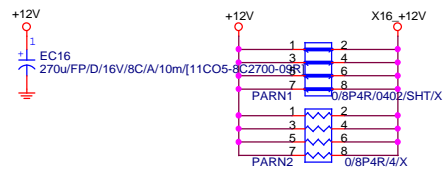

PCIEX16 AC CAP

PA EXP TXP0	PAC5	0.22u/4/X5R/6.3V/K	PA EXP TXP0 C
PA EXP TXN0	PAC4	0.22u/4/X5R/6.3V/K	PA EXP TXN0 C
PA EXP TXP1	PAC6	0.22u/4/X5R/6.3V/K	PA EXP TXP1 C
PA EXP TXN1	PAC7	0.22u/4/X5R/6.3V/K	PA EXP TXN1 C
PA EXP TXP2	PAC8	0.22u/4/X5R/6.3V/K	PA EXP TXP2 C
PA EXP TXN2	PAC9	0.22u/4/X5R/6.3V/K	PA EXP TXN2 C
PA EXP TXP3	PAC10	0.22u/4/X5R/6.3V/K	PA EXP TXP3 C
PA EXP TXN3	PAC11	0.22u/4/X5R/6.3V/K	PA EXP TXN3 C
PA EXP TXP4	PAC12	0.22u/4/X5R/6.3V/K	PA EXP TXP4 C
PA EXP TXN4	PAC13	0.22u/4/X5R/6.3V/K	PA EXP TXN4 C
PA EXP TXP5	PAC14	0.22u/4/X5R/6.3V/K	PA EXP TXP5 C
PA EXP TXN5	PAC15	0.22u/4/X5R/6.3V/K	PA EXP TXN5 C
PA EXP TXP6	PAC16	0.22u/4/X5R/6.3V/K	PA EXP TXP6 C
PA EXP TXN6	PAC17	0.22u/4/X5R/6.3V/K	PA EXP TXN6 C
PA EXP TXP7	PAC18	0.22u/4/X5R/6.3V/K	PA EXP TXP7 C
PA EXP TXN7	PAC19	0.22u/4/X5R/6.3V/K	PA EXP TXN7 C
PA EXP TXP8	PAC20	0.22u/4/X5R/6.3V/K	PA EXP TXP8 C
PA EXP TXN8	PAC21	0.22u/4/X5R/6.3V/K	PA EXP TXN8 C
PA EXP TXP9	PAC23	0.22u/4/X5R/6.3V/K	PA EXP TXP9 C
PA EXP TXN9	PAC25	0.22u/4/X5R/6.3V/K	PA EXP TXN9 C
PA EXP TXP10	PAC24	0.22u/4/X5R/6.3V/K	PA EXP TXP10 C
PA EXP TXN10	PAC26	0.22u/4/X5R/6.3V/K	PA EXP TXN10 C
PA EXP TXP11	PAC27	0.22u/4/X5R/6.3V/K	PA EXP TXP11 C
PA EXP TXN11	PAC28	0.22u/4/X5R/6.3V/K	PA EXP TXN11 C
PA EXP TXP12	PAC29	0.22u/4/X5R/6.3V/K	PA EXP TXP12 C
PA EXP TXN12	PAC30	0.22u/4/X5R/6.3V/K	PA EXP TXN12 C
PA EXP TXP13	PAC31	0.22u/4/X5R/6.3V/K	PA EXP TXP13 C
PA EXP TXN13	PAC32	0.22u/4/X5R/6.3V/K	PA EXP TXN13 C
PA EXP TXP14	PAC33	0.22u/4/X5R/6.3V/K	PA EXP TXP14 C
PA EXP TXN14	PAC34	0.22u/4/X5R/6.3V/K	PA EXP TXN14 C
PA EXP TXP15	PAC35	0.22u/4/X5R/6.3V/K	PA EXP TXP15 C
PA EXP TXN15	PAC35	0.22u/4/X5R/6.3V/K	PA EXP TXN15 C

PA EXP RXPI0..15] >>> PA_EXP_RXPI[0..15] 4
 PA EXP RXN0..15] >>> PA_EXP_RXN[0..15] 4
 PA EXP TXPI0..15] >>> PA_EXP_TXPI[0..15] 4
 PA EXP TXN0..15] >>> PA_EXP_TXN[0..15] 4

PCIEX16 SLOT

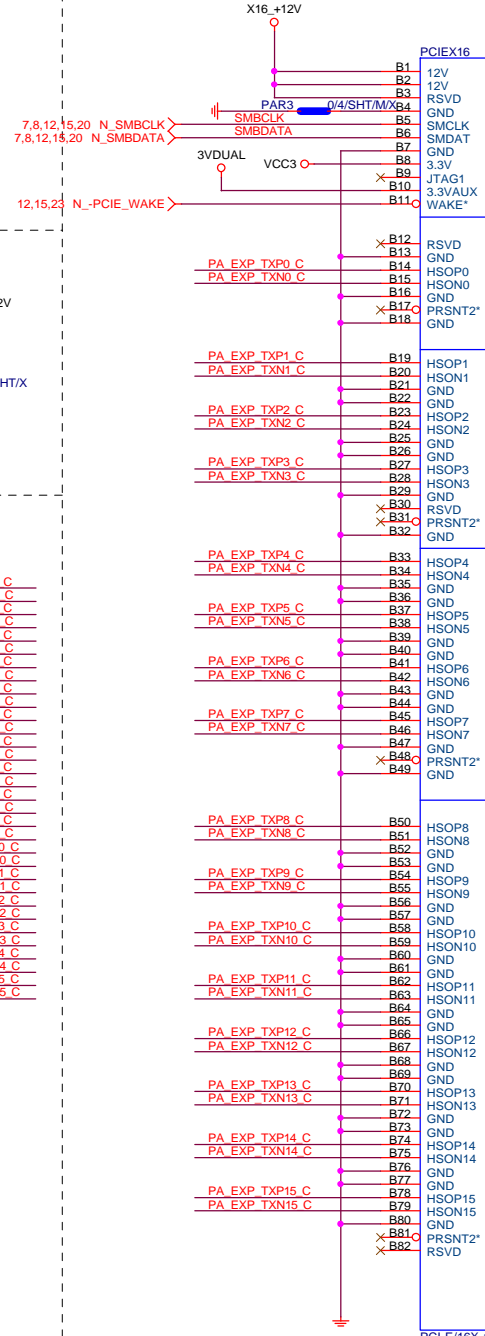

PCIESLOT-164DN-P

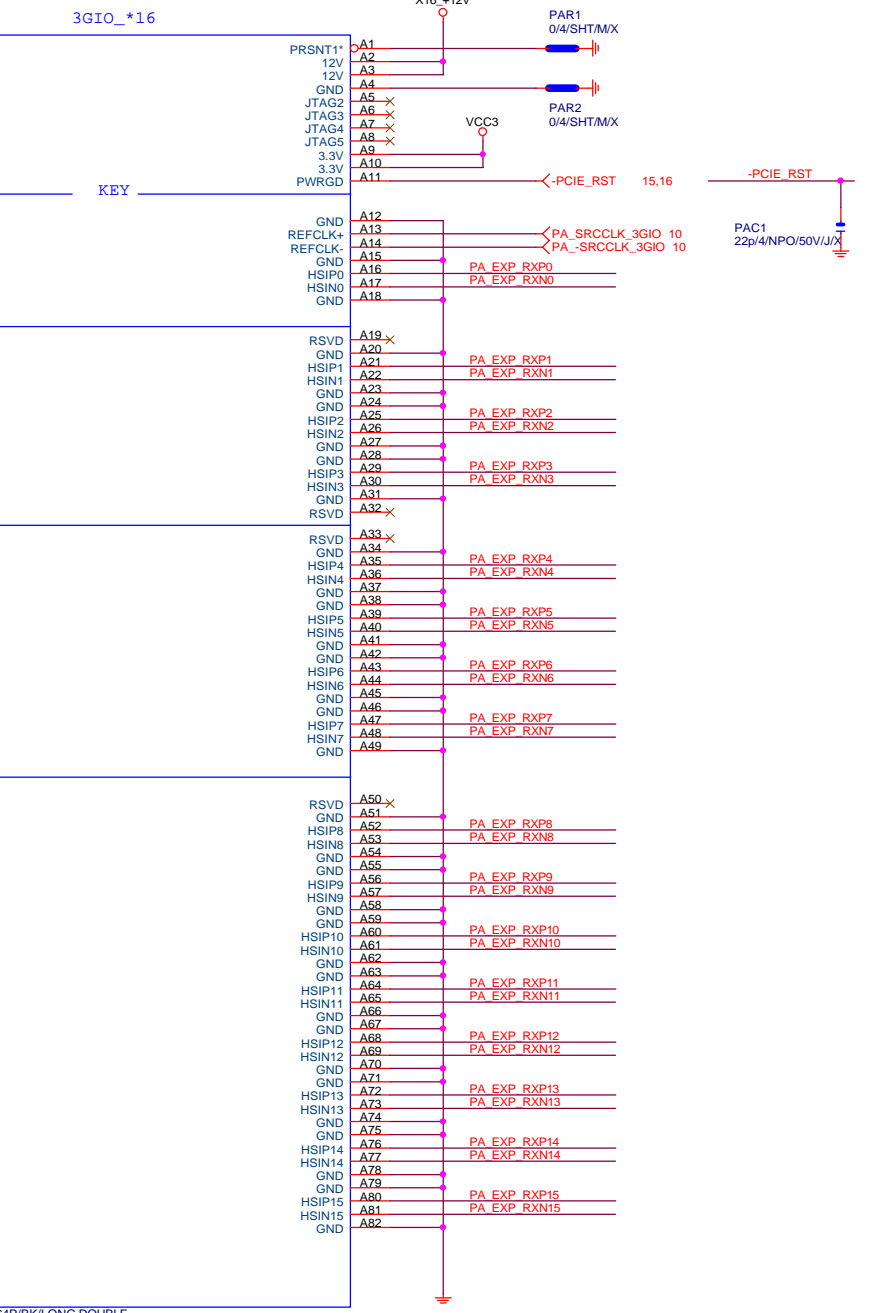

BLACK CONNECTOR

Gigabyte Technology

PCI EXPRESS * 16

Title	Document Number		Rev
Size	GA-H81M-DS2		2.0
Custom			
Date:	Monday, October 14, 2013	Sheet	14 of 29

PCIEX1 SLOT

PCIEX1 PROTECT SHT

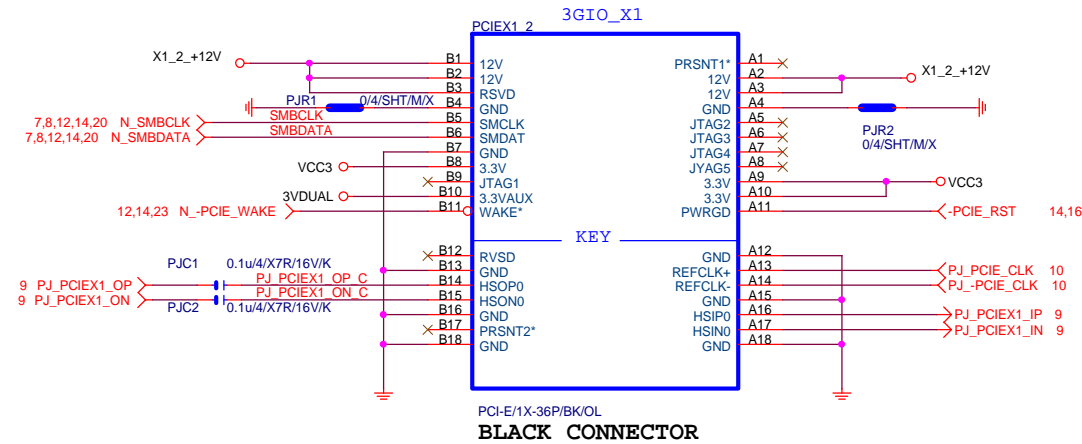
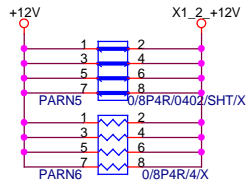
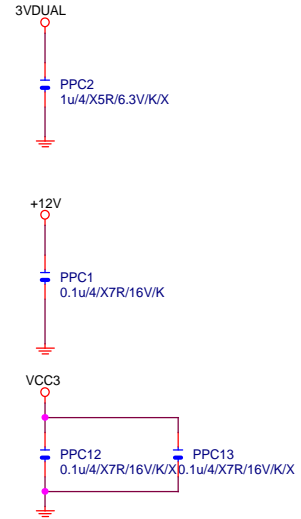
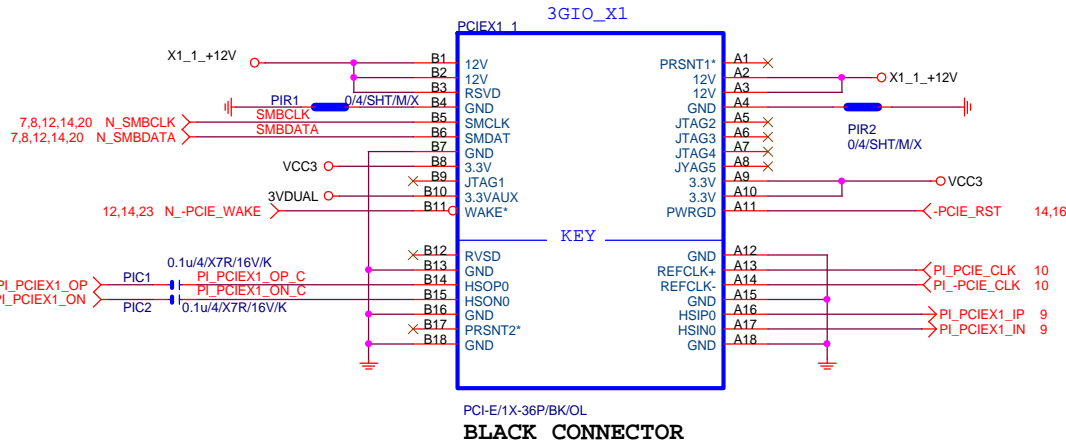
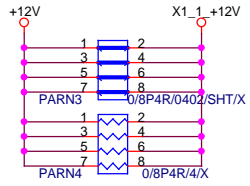

Gigabyte Technology

Title		
PCI EXPRESS X 1 PORT		
Size	Document Number	Rev
Custom	GA-H81M-DS2	2.0
Date:	Monday, October 14, 2013	Sheet 15 of 29

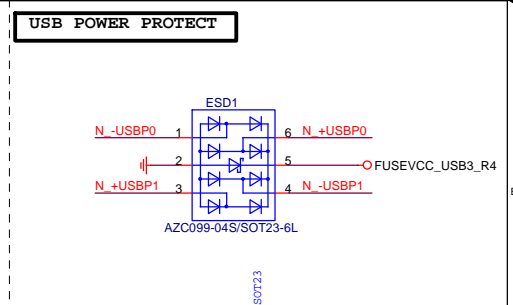
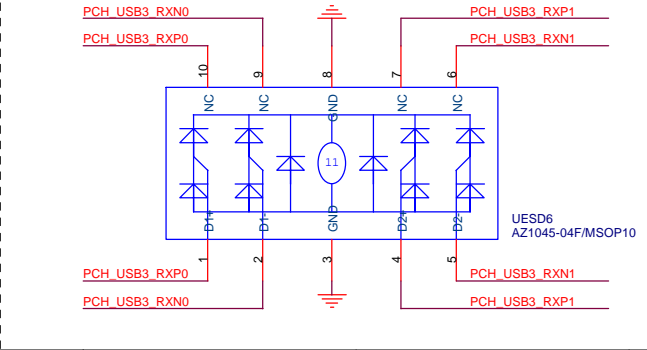
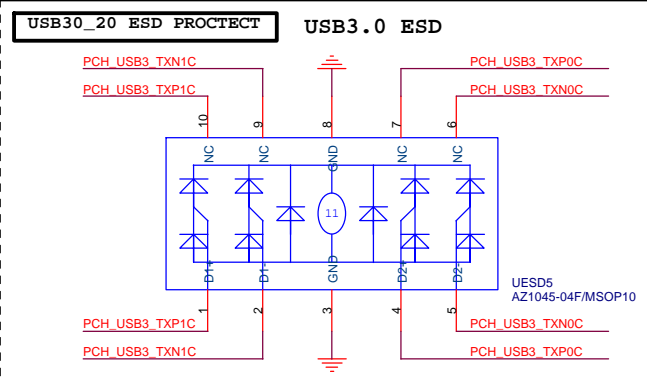
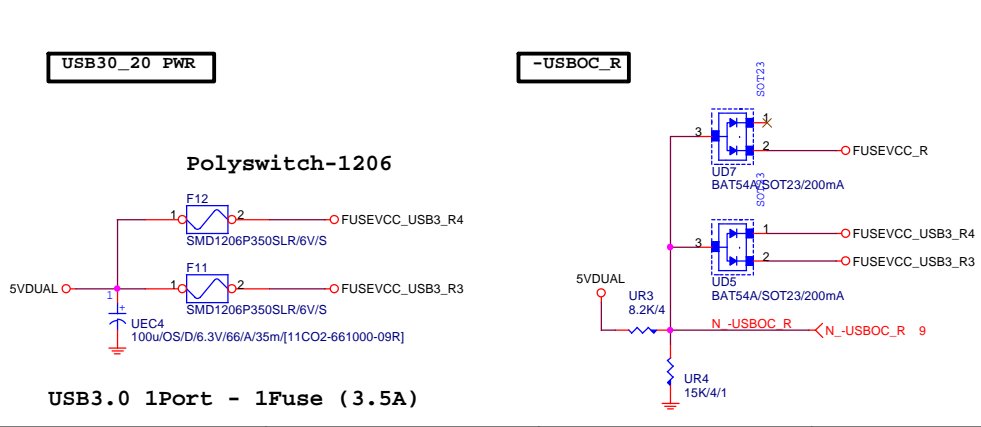
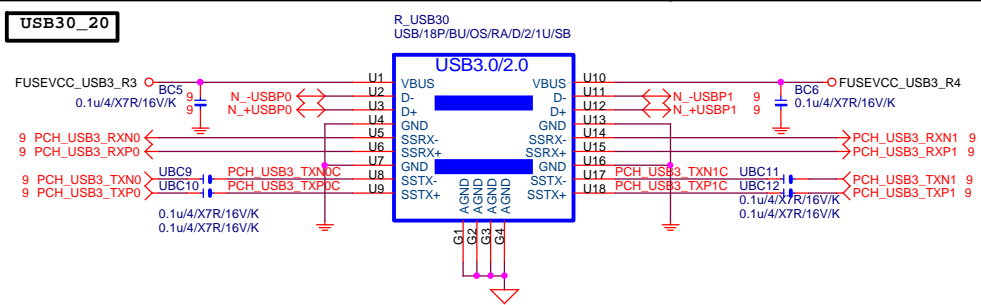
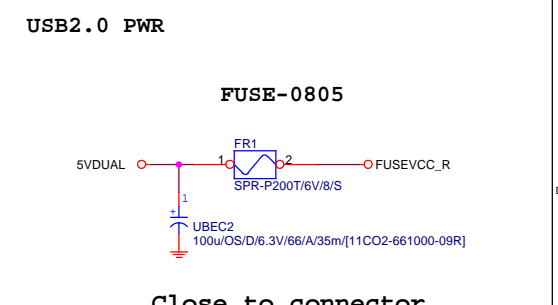
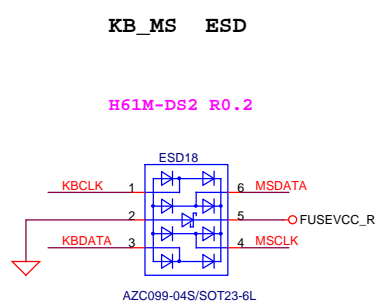
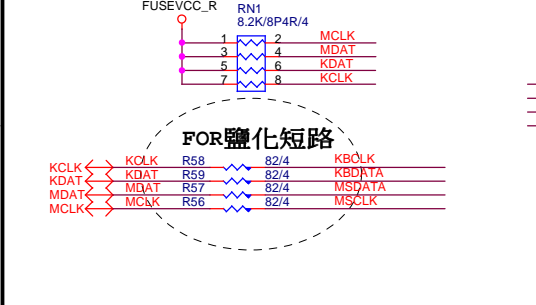
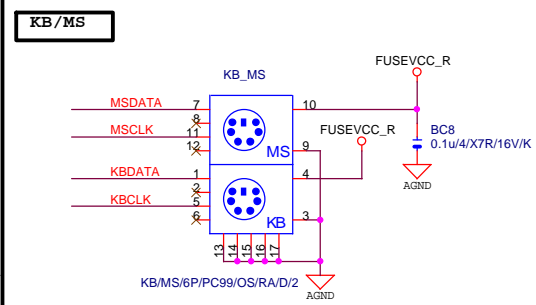
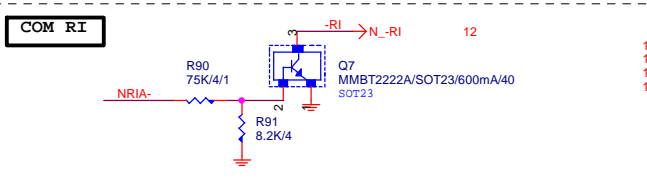
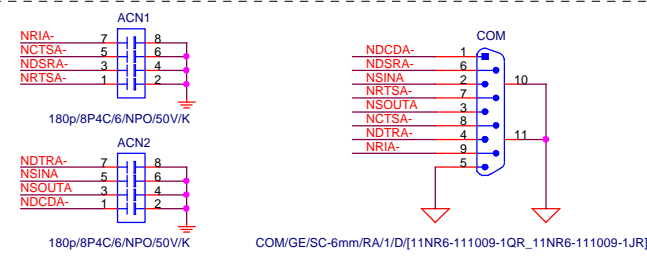
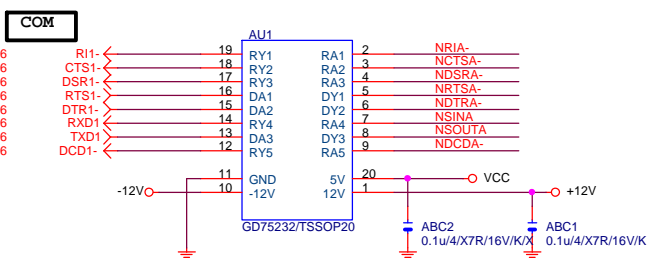

TEMP H/W MONITOR

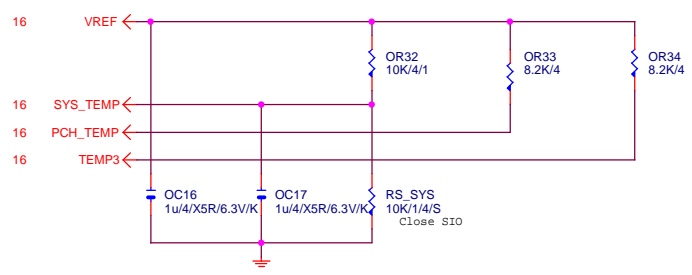

CPU SMART FAN

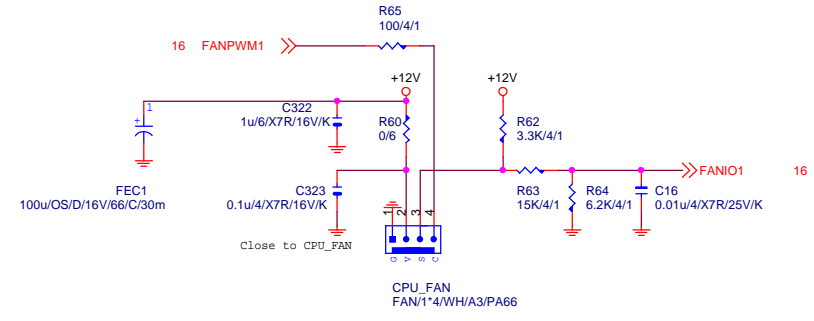

CASE OPEN

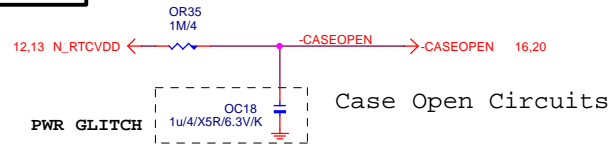

SYS SMART FAN

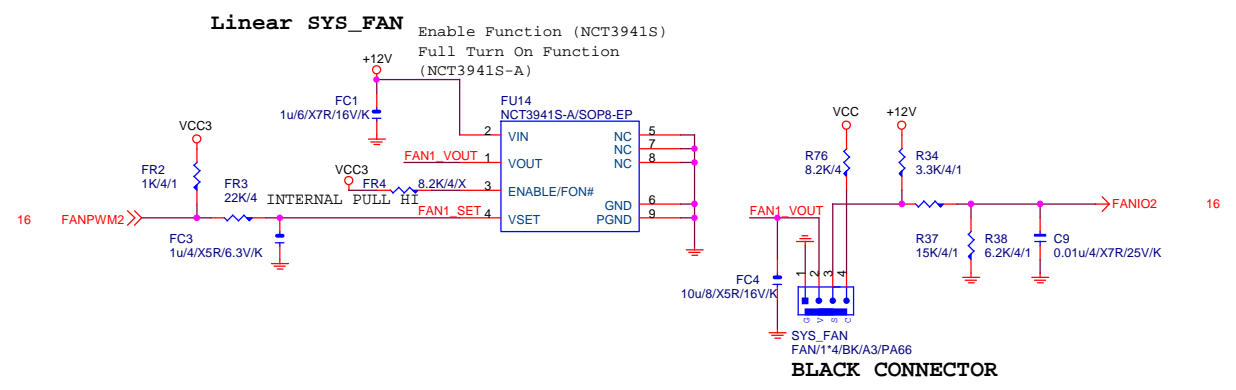

VOLTAGE-- H/W MONITOR

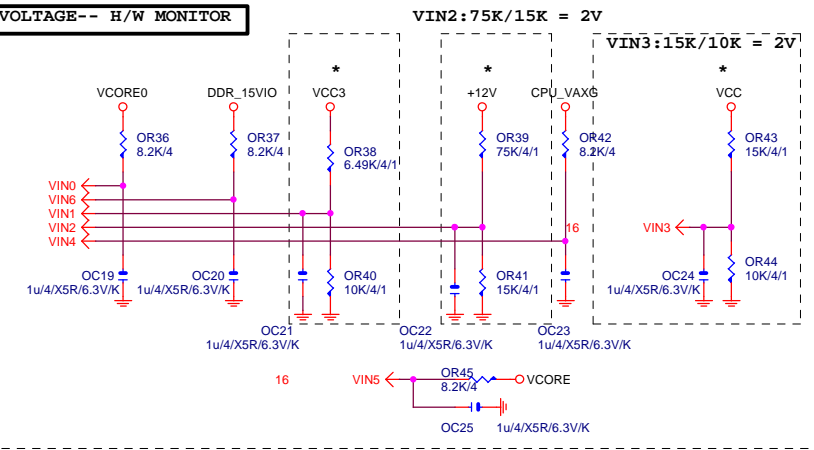

-PROHOT

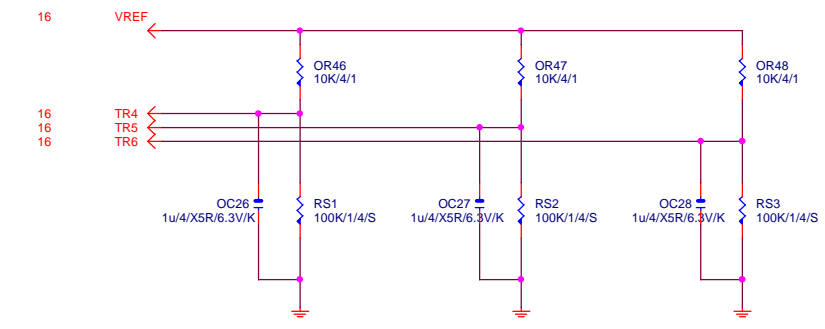
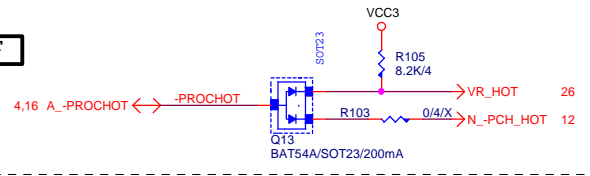

RS1、RS2、RS3 CLOSE CPU VR MOSFET

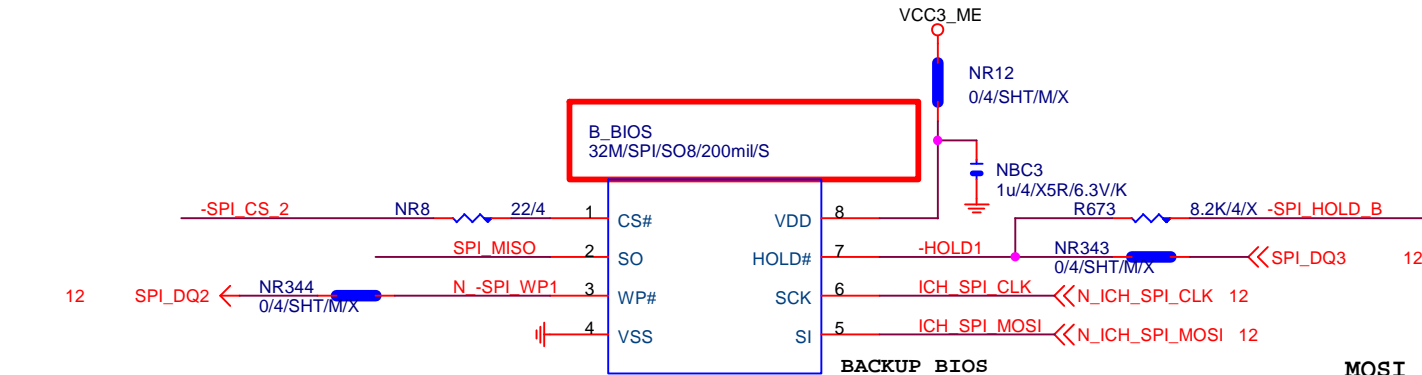
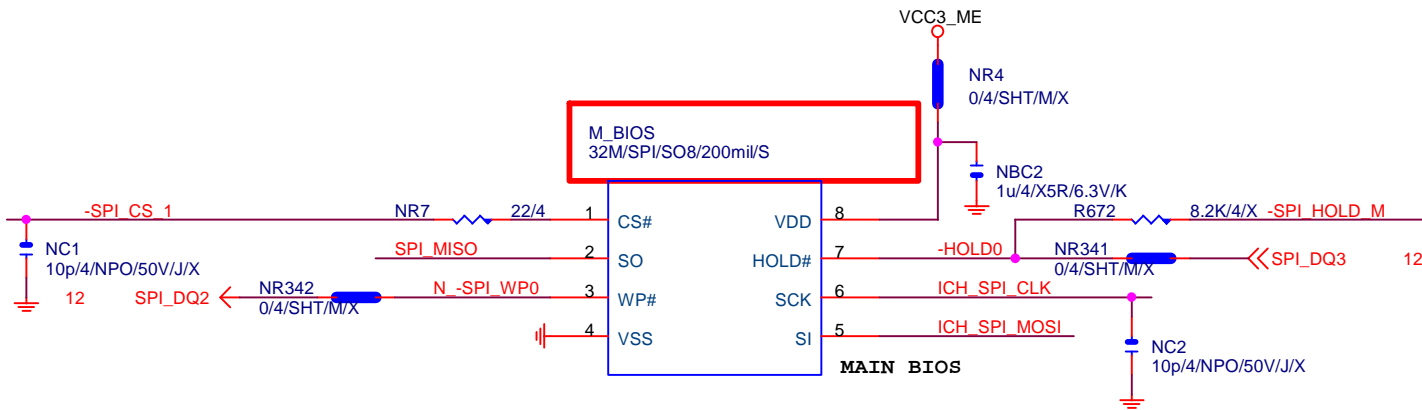

BOOT DEVICE	GNT0	GNT1
LPC	0	0
PCI	0	1
NAND	1	0
SPI	1	1

1 means floating
0 means PD 1K

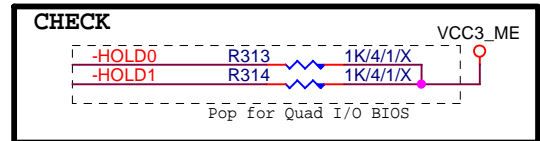
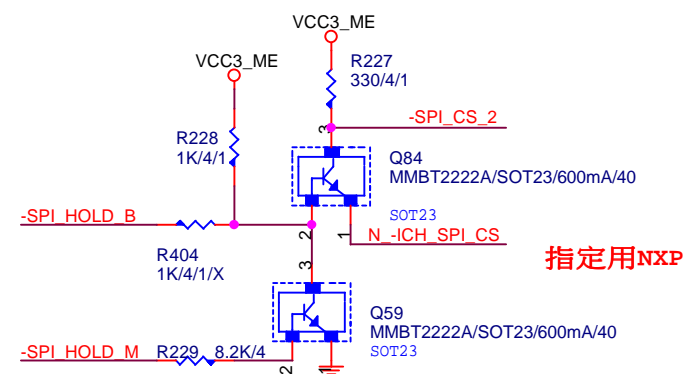
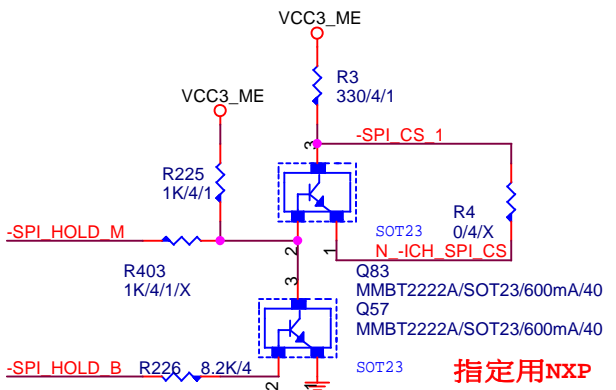
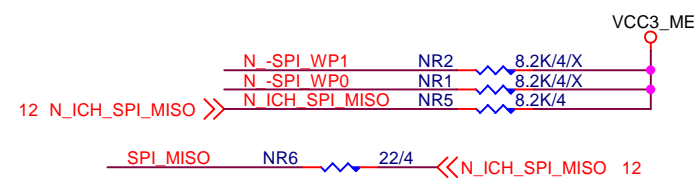
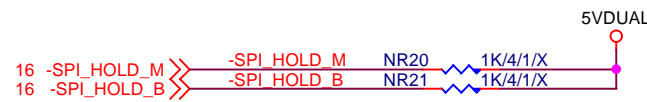
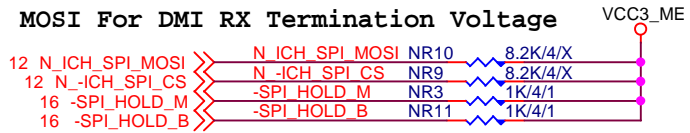

Gigabyte Technology

DUAL BIOS

Title: **GA-H81M-DS2**

Size Custom	Document Number	Rev 2.0
Date: Monday, October 14, 2013	Sheet 19 of 29	

	ALC892	ALC887-VD2	VT1708S-CE
CR44/CBC26	47ohm+1nF	47ohm+1nF	22ohm+100P
CBC42/CBC43	X	X	100P/4
CR6/CR7/CR58/CR54/ CR67/CR68/CR69/CR70	22K/4	22K/4	10K/4/1
CR5/CR8/CR1/CR14/ CR17/CR22/CR73/CR74/ CR13/CR11/CR57/CR53/ CR75/CR76	62 ohm	62 ohm	75 ohm
CR51/CD1/CBC7	O	O	O
CESD1	O	O	O

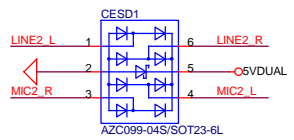
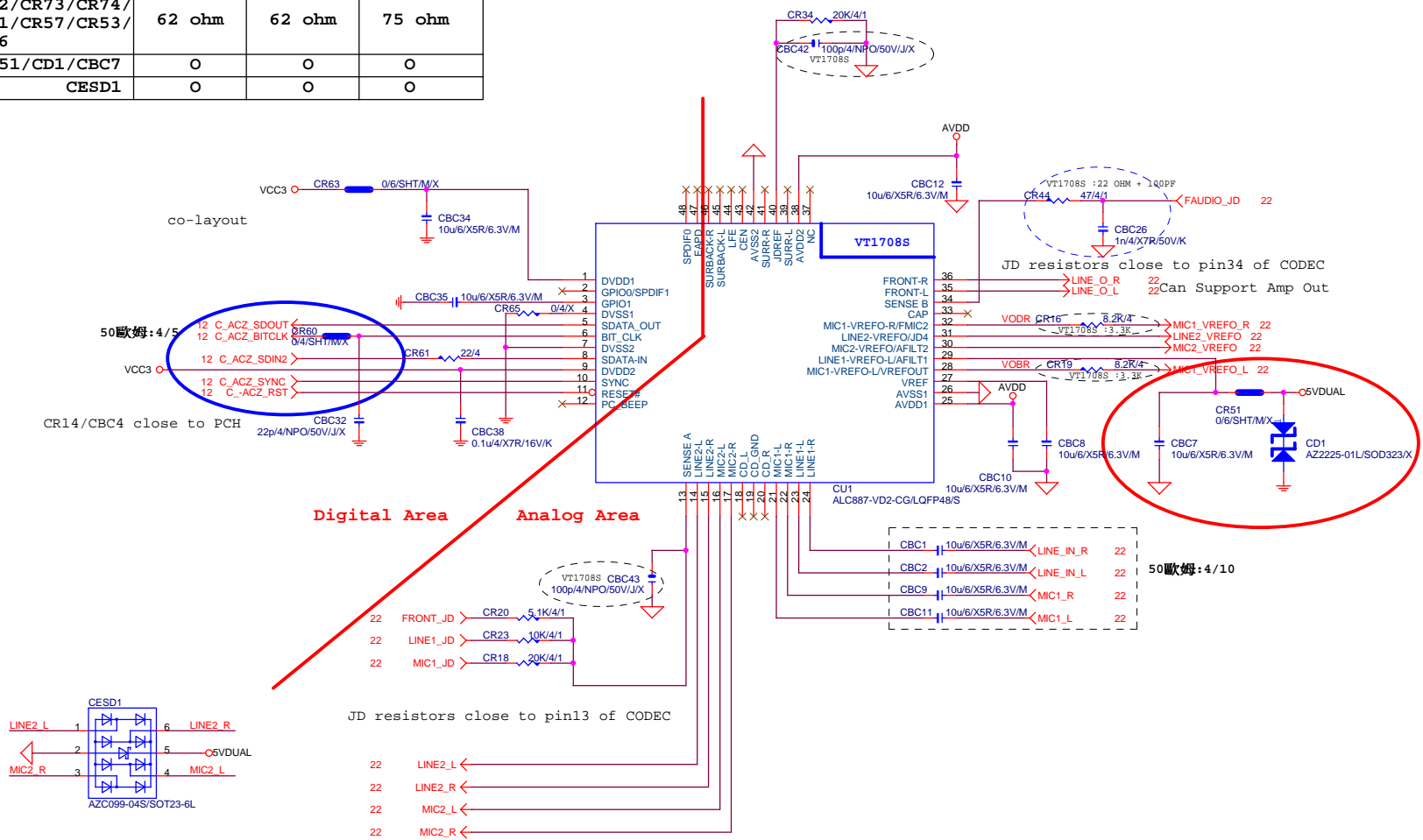

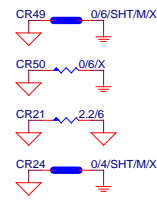

LINE-OUT

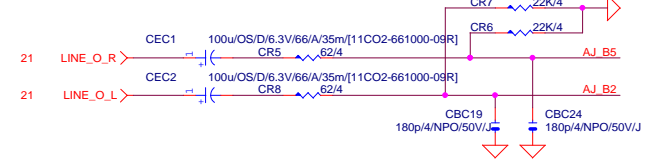

LINE-IN

Only reserved for ALC888

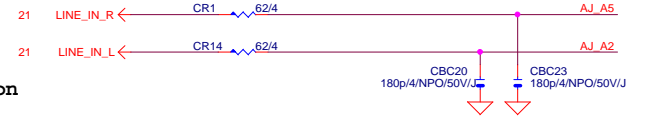

Verify MIC function in LINE-in

For 889A/888

MIC-IN

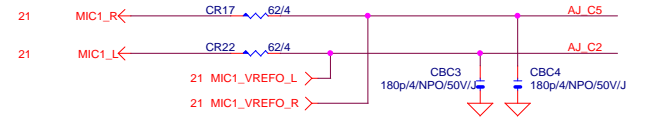

SPDIF_OUT

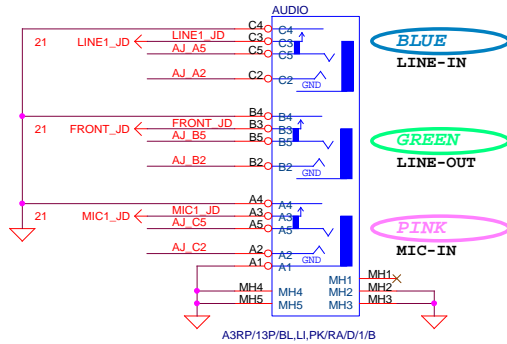

AZALIA FRONT PANEL

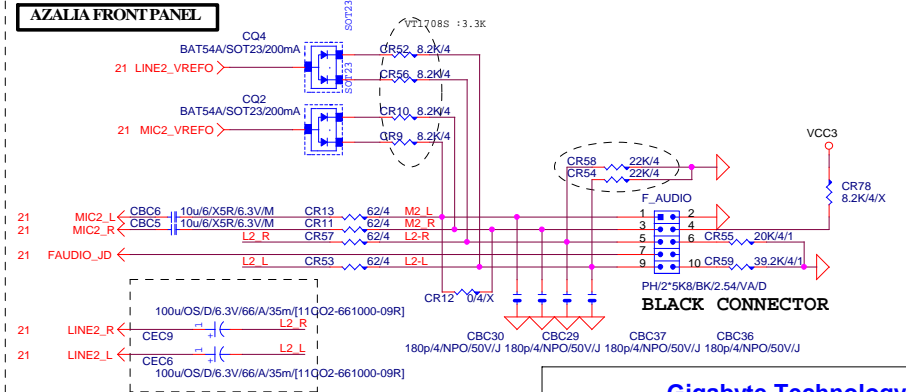

Gigabyte Technology

Title			AUDIO JACK		
Size Custom			Document Number		
Date:			Rev 2.0		
Monday, October 14, 2013			Sheet 22 of 29		

ATXX24 POWER CONNECTOR

【技術通報R&D技術通報155】

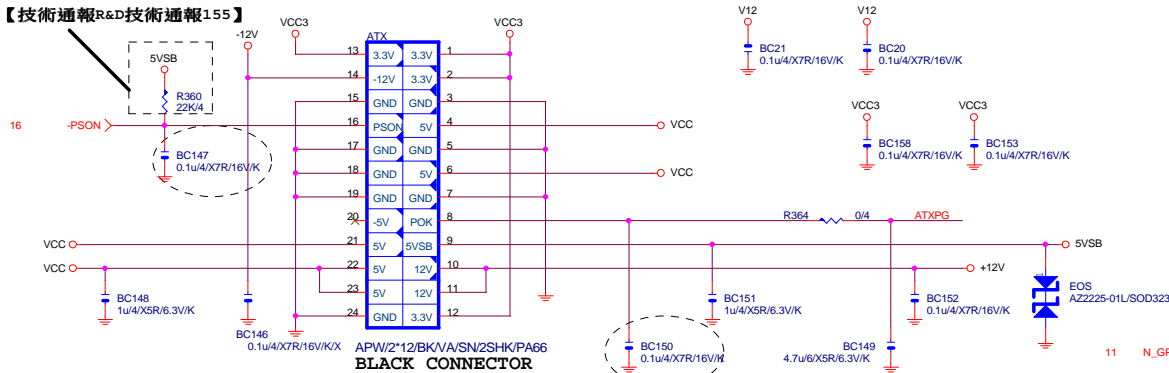

【技術通報R&D技術通報155】

To fix 12V light load abnormal issue

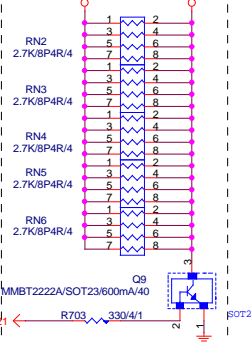

ATXX4 POWER CONNECTOR

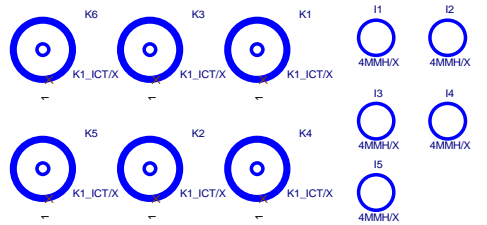
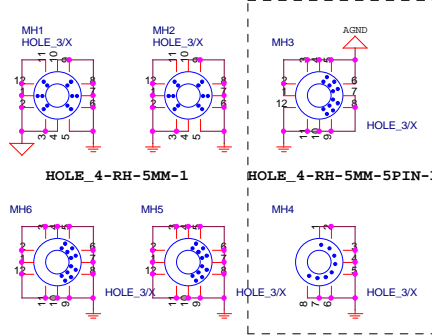
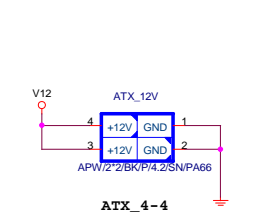

PWOK PATCH

【技術通報R&D技術通報154】

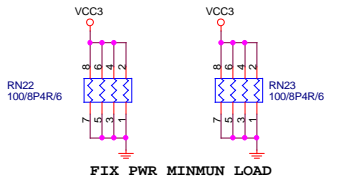
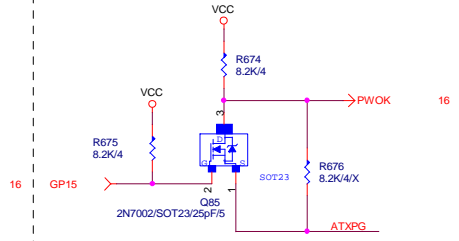

R_PROG1 (Kohm)	3-Phase Iccmax (A)
24.9	105
28.7	114
34.0	129
42.2	144

R_PROG2 (Kohm)	Fsw (KHz)	VBOOT
64.9	315	1.75
73.2	315	1.70
80.6	315	1.65
90.9	315	0

R_PROG3 (Kohm)	Fast Slew Rate (mV/us)
3.24	12
5.76	24
9.31	40
13.3	45

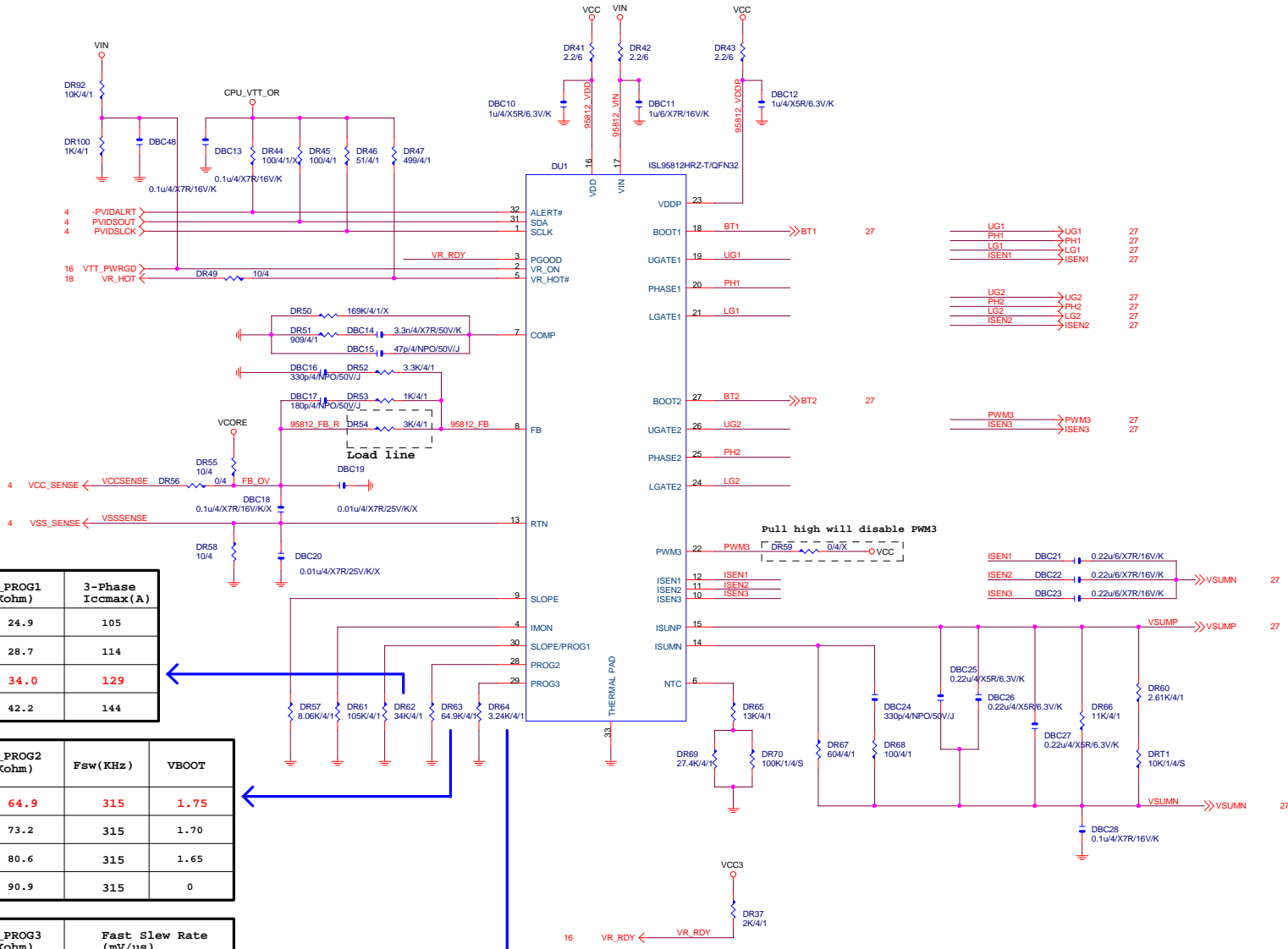

PHASE 1

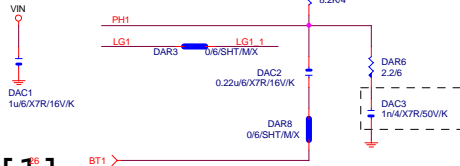
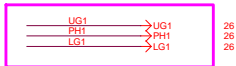

[1]

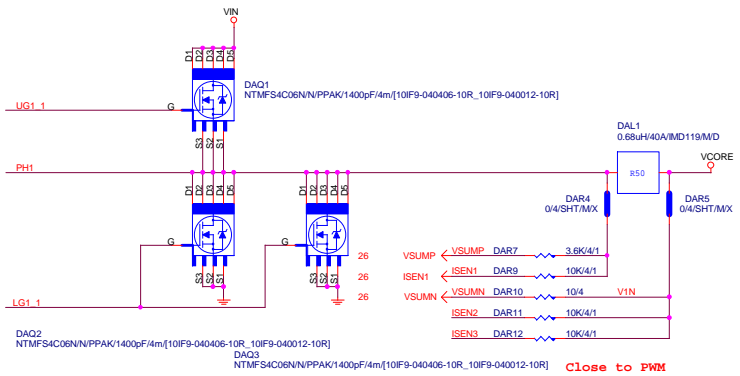

PHASE 3

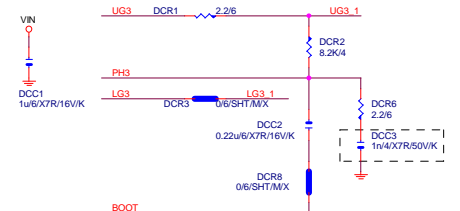
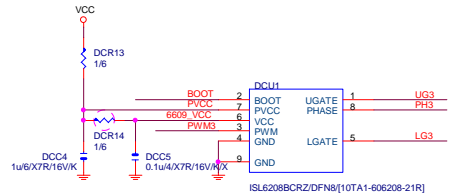

[3]

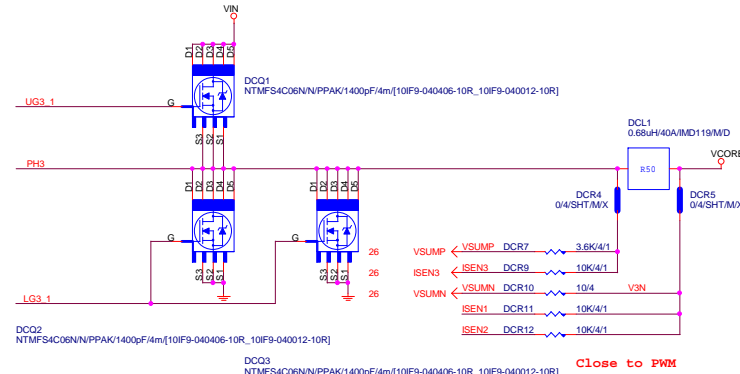

PHASE 2

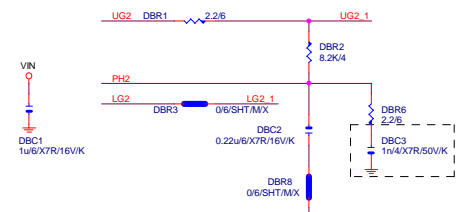

[2]

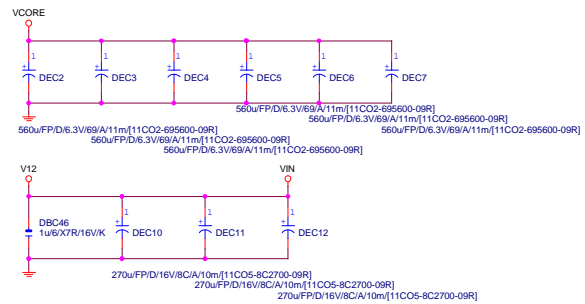
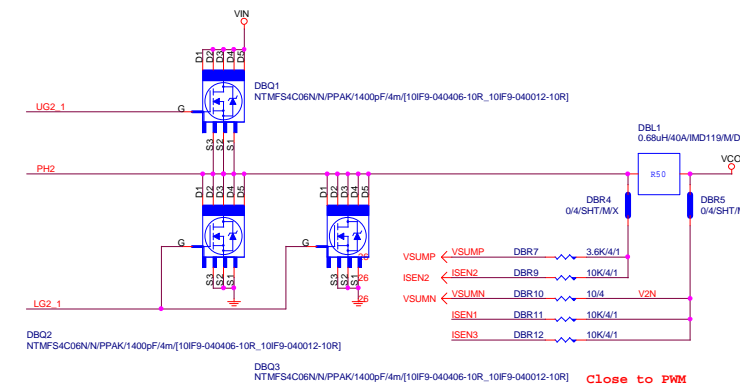

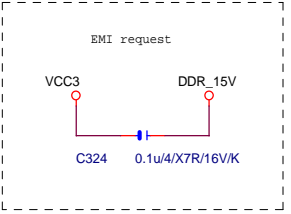
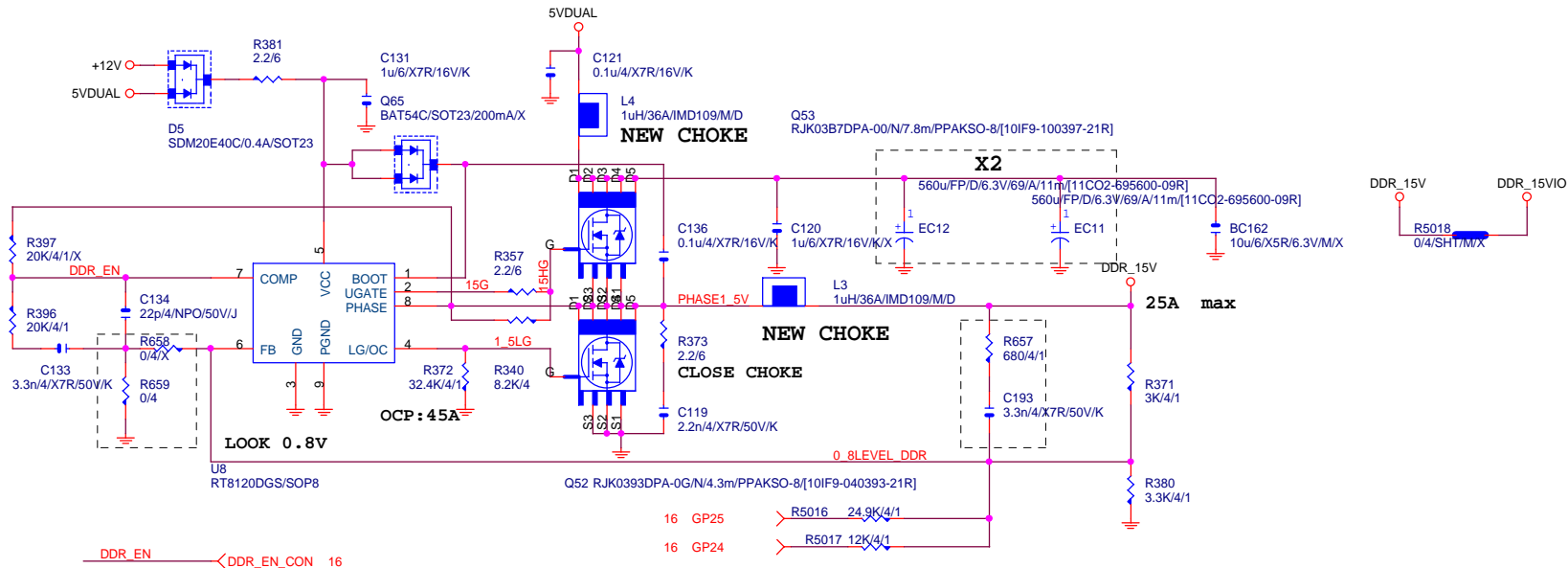

VIN=5V, VOUT=1.5V, IOU=25A, PHASE=1
 IRMS=11.45A
 560u/FP/D/6.3V/68/8m RIPPLE CURRENT=4.7A
 Coefficient=1.7(85°C), 1(105°C)
 VIN Ripple current=4.7X1.7=7.99A(85°C)
 -->故固態電容須2X7.99=15.98>11.45A

Rocset=(Iocp*Lgate, rdson) / Iocset
 Rocset=(45A*6.7mOhm) / 10uA = 30K
 Iocset=10uA

Gigabyte Technology

Title		
DDR POWER		
Size	Document Number	Rev
Custom	GA-H81M-DS2	2.0
Date:	Monday, October 14, 2013	Sheet 28 of 29

