

SHEET TITLE

01	COVER SHEET
02	BOM & PCB MODIFY HISTORY
03	BLOCK DIAGRAM
04	CPU_LGA1155-A
05	CPU_LGA1155-B
06	CPU_LGA1155-C
07	DDR III CHANNEL A
08	DDR III CHANNEL B
09	PCH_FDI,DMI,USB,PCIE,NVRAM
10	PCH_DP,CLK BUFFER
11	PCH_HOST,SATA,PCI
12	PCH_GPIO,CTRL,AUDIO
13	PCH_PWR,GND
14	PCI EXPRESS*16 SLOT
15	PCI EXPRESS*1x2 SLOT
16	ITE 8620 LPC IO
17	KB_MS,R_USB,-PROCHOT
18	HWM,FAN CTRL,OV
19	Dual BIOS
20	FP,FUSB,SPK,SATALED
21	ALC887
22	REAR AUDIO JACK
23	REALTEK 8111F/USB_LAN
24	DISCRETE POWER
25	ATX,-S_WARN,-S_ACK,5VDUAL
26	CPU_VTT
27	VCORE INTERSIL_95836_1

SHEET TITLE

28	VCORE INTERSIL_95836_2
29	VCORE INTERSIL_95836_3
30	LPT

BLOCK DIAGRAM

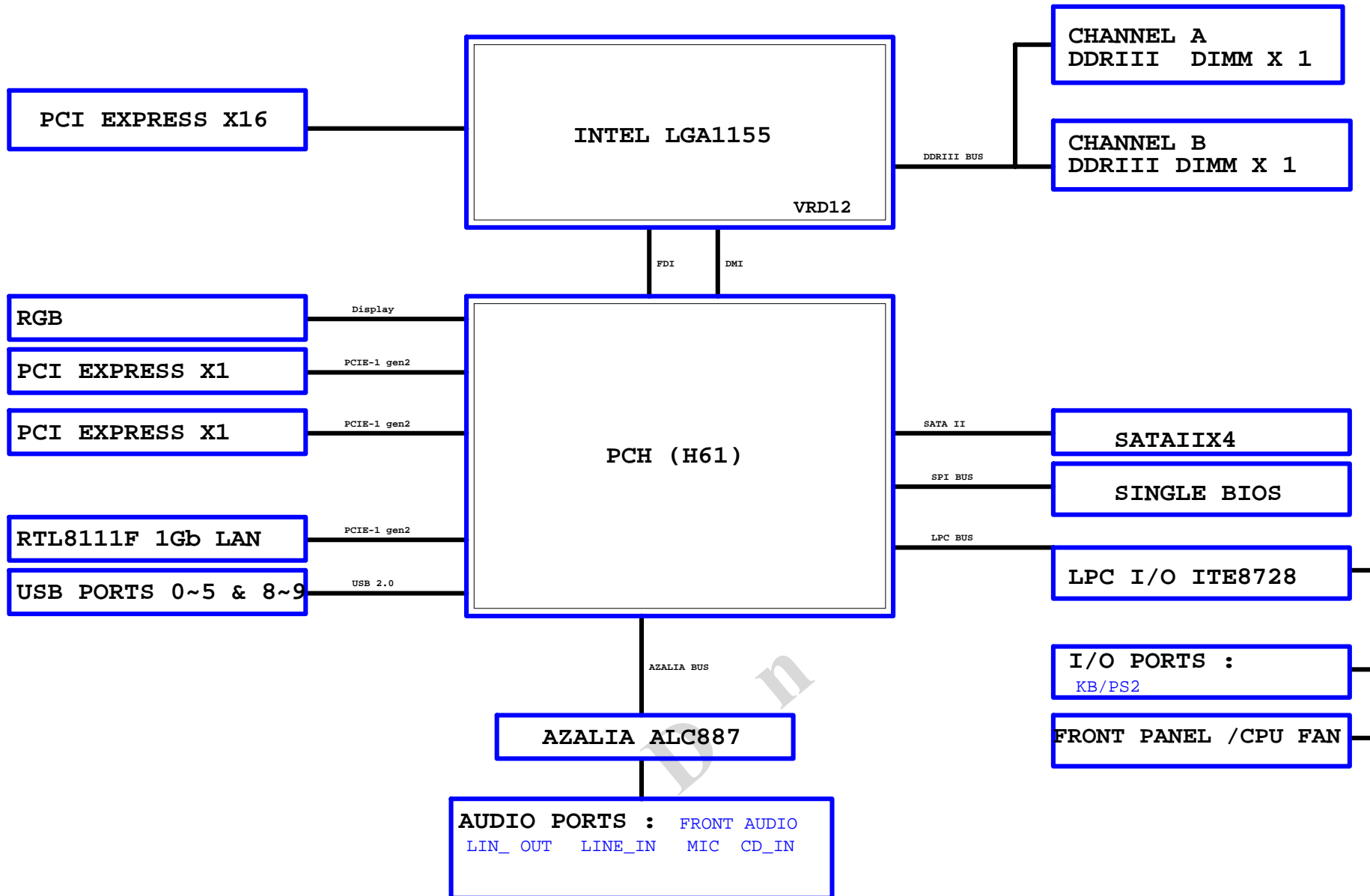

CPUA	
MAAA0	AV27 SA_MA[0]
MAAA1	AY24 SA_MA[1]
MAAA2	AW24 SA_MA[2]
MAAA3	AW23 SA_MA[3]
MAAA4	AV23 SA_MA[4]
MAAA5	AT24 SA_MA[5]
MAAA6	AT23 SA_MA[6]
MAAA7	AU22 SA_MA[7]
MAAA8	AV22 SA_MA[8]
MAAA9	AT22 SA_MA[9]
MAAA10	AV28 SA_MA[10]
MAAA11	AU21 SA_MA[11]
MAAA12	AT21 SA_MA[12]
MAAA13	AW32 SA_MA[13]
MAAA14	AU20 SA_MA[14]
MAAA15	AT20 SA_MA[15]
7	-SWEA ← -SWEA AW29 SA_WE#
7	-SCASA ← -SCASA AV30 SA_CAS#
7	-SRASA ← -SRASA AU28 SA_RAS#
7	SBA00 ↔ SBA00 AY29 SA_BS[0]
7	SBA01 ↔ SBA01 AW28 SA_BS[1]
7	SBA02 ↔ SBA02 AV20 SA_BS[2]
7	-CSA0 ↔ -CSA0 AU29 SA_CS#0
7	-CSA1 ↔ -CSA1 AV32 SA_CS#1
7	-CSA1 ↔ -CSA1 AW30 SA_CS#2
7	-CSA1 ↔ -CSA1 AU33 SA_CS#3
7	CKEA0 ↔ CKEA0 AV19 SA_CKE[0]
7	CKEA1 ↔ CKEA1 AT19 SA_CKE[1]
7	CKEA1 ↔ CKEA1 AU18 SA_CKE[2]
7	CKEA1 ↔ CKEA1 AV18 SA_CKE[3]
7	MODT_A0 ↔ MODT_A0 AV31 SA_ODT[0]
7	MODT_A1 ↔ MODT_A1 AU32 SA_ODT[1]
7	MODT_A1 ↔ MODT_A1 AU30 SA_ODT[2]
7	MODT_A1 ↔ MODT_A1 AW33 SA_ODT[3]
7	DCLKA0 ↔ DCLKA0 AY25 SA_CK[0]
7	-DCLKA0 ↔ -DCLKA0 AW25 SA_CK#0
7	-DCLKA0 ↔ -DCLKA0 AU24 SA_CK[1]
7	-DCLKA1 ↔ -DCLKA1 AU24 SA_CK[2]
7	-DCLKA1 ↔ -DCLKA1 AW27 SA_CK#1
7	-DCLKA1 ↔ -DCLKA1 AY27 SA_CK#2
7	-DCLKA1 ↔ -DCLKA1 AV26 SA_CK[3]
7	-DCLKA1 ↔ -DCLKA1 AW28 SA_CK#3
7.8	-DDR3_RST ← -DDR3_RST AW18 SM_DRAMRST#
7	C97 0.1u/4/X7R/16V/K/KX
7	R240 0/4/SHT/M/X
7	AV13 SA_DQS[8]
7	AV12 SA_DQS#8
7	AU12 SA_ECC_CB[0]
7	AU14 SA_ECC_CB[1]
7	AW13 SA_ECC_CB[2]
7	AY13 SA_ECC_CB[3]
7	AU11 SA_ECC_CB[4]
7	AY12 SA_ECC_CB[5]
7	AW12 SA_ECC_CB[6]
7	AW12 SA_ECC_CB[7]
7	AR40 MDA40
7	AR37 MDA41
7	AN38 MDA42
7	AN37 MDA43
7	AR39 MDA44
7	AR38 MDA45
7	AN39 MDA46
7	AN40 MDA47
7	AK38 DQSA6
7	AK39 -DQSA6
7	AL40 MDA48
7	AL37 MDA49
7	AJ38 MDA50
7	AJ37 MDA51
7	AL39 MDA52
7	AL38 MDA53
7	AJ39 MDA54
7	AJ40 MDA55
7	AF38 DQSA7
7	AF39 -DQSA7
7	AG40 MDA56
7	AG37 MDA57
7	AE38 MDA58
7	AE37 MDA59
7	AG39 MDA60
7	AG38 MDA61
7	AE39 MDA62
7	AE40 MDA63

DDR_0

1 OF 10

LGA1155[10SC1-F01155-01R_10SC1-F01155-02R]

CPUB	
MAAB0	AK24 SB_MA[0]
MAAB1	AM20 SB_MA[1]
MAAB2	AM19 SB_MA[2]
MAAB3	AK18 SB_MA[3]
MAAB4	AP19 SB_MA[4]
MAAB5	AP18 SB_MA[5]
MAAB6	AM18 SB_MA[6]
MAAB7	AL18 SB_MA[7]
MAAB8	AN18 SB_MA[8]
MAAB9	AY17 SB_MA[9]
MAAB10	AN23 SB_MA[10]
MAAB11	AU17 SB_MA[11]
MAAB12	AT18 SB_MA[12]
MAAB13	AR26 SB_MA[13]
MAAB14	AY16 SB_MA[14]
MAAB15	AV16 SB_MA[15]
8	-SWEB ← -SWEB AR25 SB_WE#
8	-SCASB ← -SCASB AK25 SB_CAS#
8	-SRASB ← -SRASB AP24 SB_RAS#
8	SBAB0 ↔ SBAB0 AP23 SB_BS[0]
8	SBAB1 ↔ SBAB1 AM24 SB_BS[1]
8	SBAB2 ↔ SBAB2 AW17 SB_BS[2]
8	-CSB0 ↔ -CSB0 AN25 SB_CS#0
8	-CSB1 ↔ -CSB1 AN26 SB_CS#1
8	-CSB1 ↔ -CSB1 AR26 SB_CS#2
8	-CSB1 ↔ -CSB1 AT26 SB_CS#3
8	CKEB0 ↔ CKEB0 AU16 SB_CKE[0]
8	CKEB1 ↔ CKEB1 AV15 SB_CKE[1]
8	CKEB1 ↔ CKEB1 AW15 SB_CKE[2]
8	CKEB1 ↔ CKEB1 AV15 SB_CKE[3]
8	MODT_B0 ↔ MODT_B0 AL26 SB_ODT[0]
8	MODT_B1 ↔ MODT_B1 AP26 SB_ODT[1]
8	MODT_B1 ↔ MODT_B1 AM26 SB_ODT[2]
8	MODT_B1 ↔ MODT_B1 AK26 SB_ODT[3]
8	DCLKB0 ↔ DCLKB0 AL21 SB_CK[0]
8	-DCLKB0 ↔ -DCLKB0 AL22 SB_CK#0
8	DCLKB1 ↔ DCLKB1 AK20 SB_CK[1]
8	-DCLKB1 ↔ -DCLKB1 AL23 SB_CK#1
8	-DCLKB1 ↔ -DCLKB1 AM22 SB_CK[2]
8	-DCLKB1 ↔ -DCLKB1 AV7 SB_CK[3]
8	-DCLKB1 ↔ -DCLKB1 AN21 SB_CK#3
8	VREF_DQB ← VREF_DQB AH1 FC_AH1
7	VREF_DOA ← VREF_DOA AH4 FC_AH4
8	AN16 SB_DQS[8]
8	AN15 SB_DQS#8
8	AN16 SB_ECC_CB[0]
8	AN16 SB_ECC_CB[1]
8	AN15 SB_ECC_CB[2]
8	AR16 SB_ECC_CB[3]
8	AL15 SB_ECC_CB[4]
8	AM15 SB_ECC_CB[5]
8	AR15 SB_ECC_CB[6]
8	AP15 SB_ECC_CB[7]
8	AP32 MDB40
8	AP21 MDB41
8	AP35 MDB42
8	AP34 MDB43
8	AR32 MDB44
8	AR31 MDB45
8	AR35 MDB46
8	AR34 MDB47
8	AL33 DQSB6
8	AM33 -DQSB6
8	AM32 MDB48
8	AM31 MDB49
8	AL35 MDB50
8	AL32 MDB51
8	AM34 MDB52
8	AL31 MDB53
8	AM35 MDB54
8	AL34 MDB55
8	AG35 DQSB7
8	AG34 -DQSB7
8	AH35 MDB56
8	AH34 MDB57
8	AE34 MDB58
8	AE35 MDB59
8	AJ35 MDB60
8	AJ34 MDB61
8	AF33 MDB62
8	AF35 MDB63

DDR_1

2 OF 10

LGA1155[10SC1-F01155-01R_10SC1-F01155-02R]

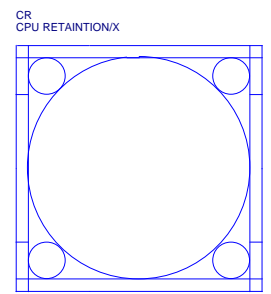

Need check the new CPU ME

CPU



ILM_BP/1156/CSP/[12KRC-0F0001-31R]

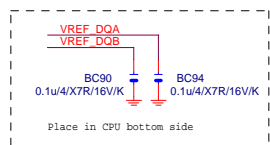

Place in CPU bottom side

Title		CPU LGA1156-B	
Size	Document Number	GA-H61M-DS2	
Custom		Rev	4.01
Date:	Wednesday, September 25, 2013	Sheet	5 of 30

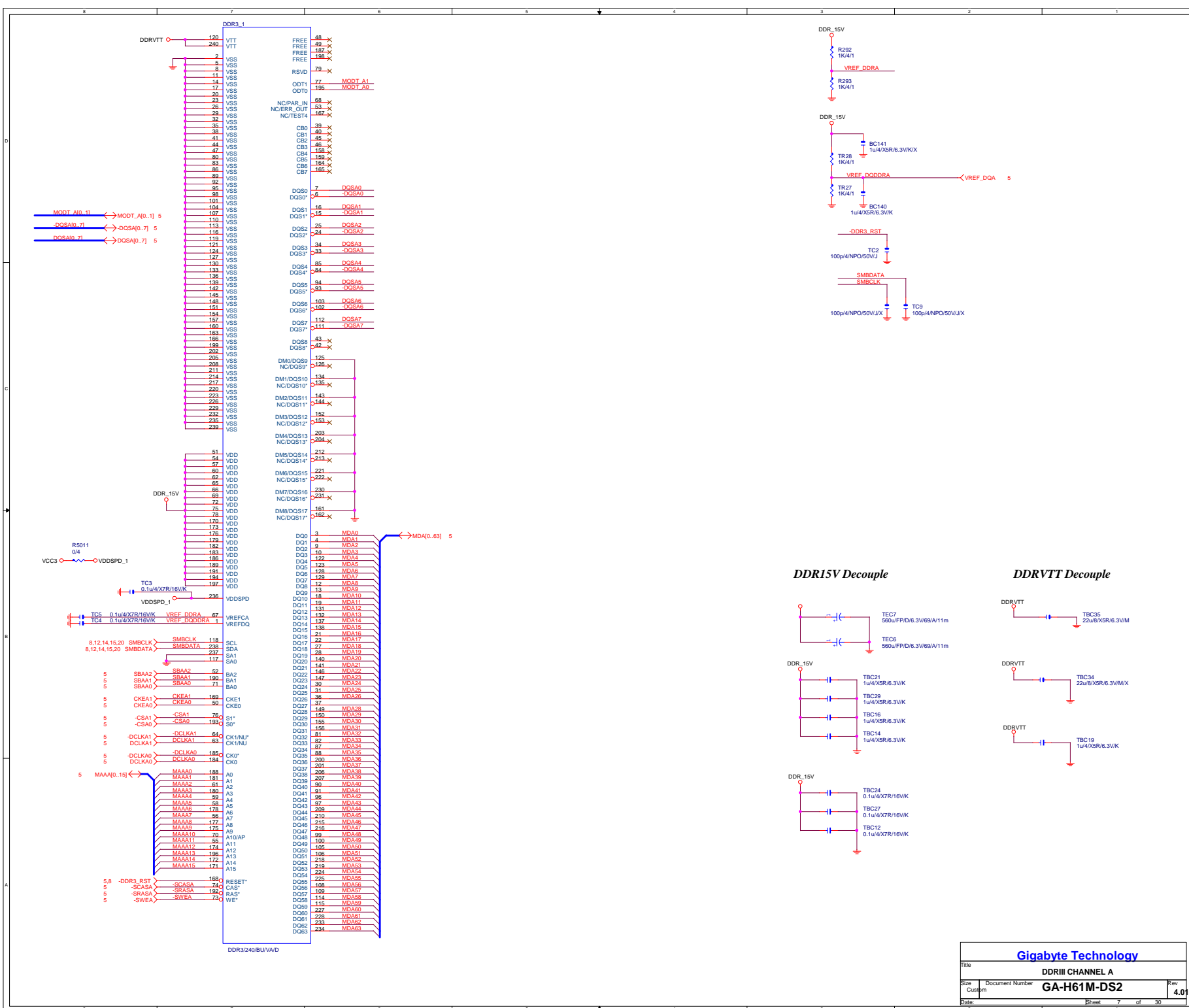

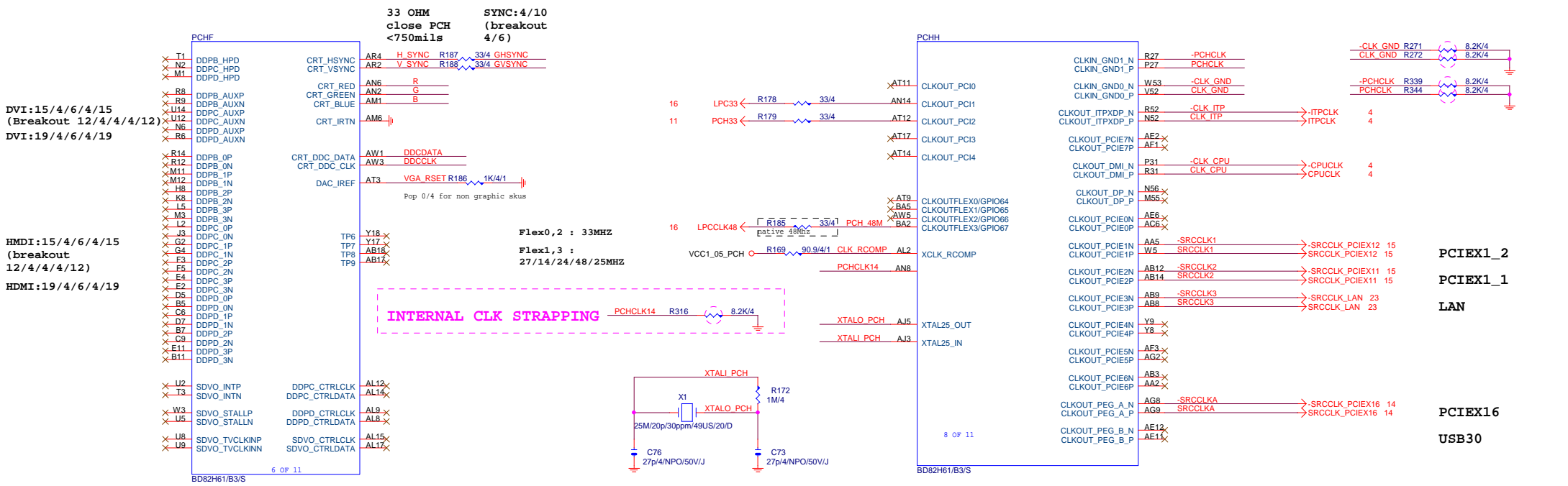

VGA DDC

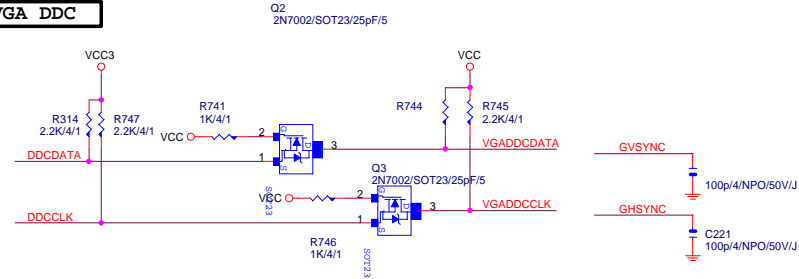

VGA DDC

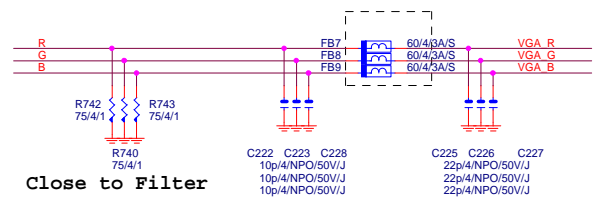

VGA CONNECTOR

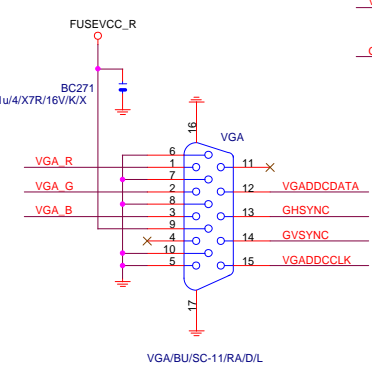

VGA ESD

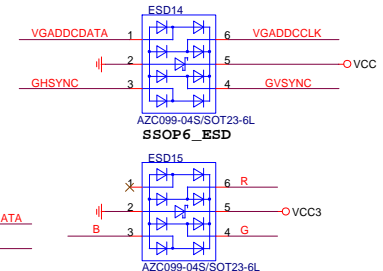

Gigabyte Technology		
PCH DISPLAY ,CLK BUFFER		
File	Document Number	Rev
	GA-H61M-DS2	4.01
Date:	Wednesday, September 25, 2013	Sheet 10 of 30

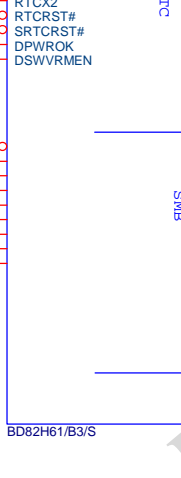
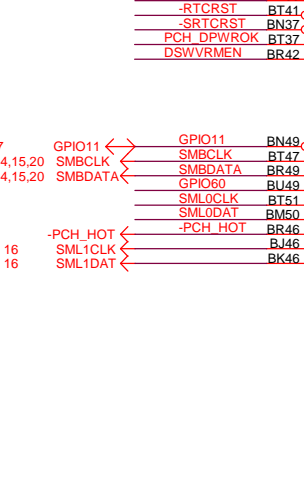
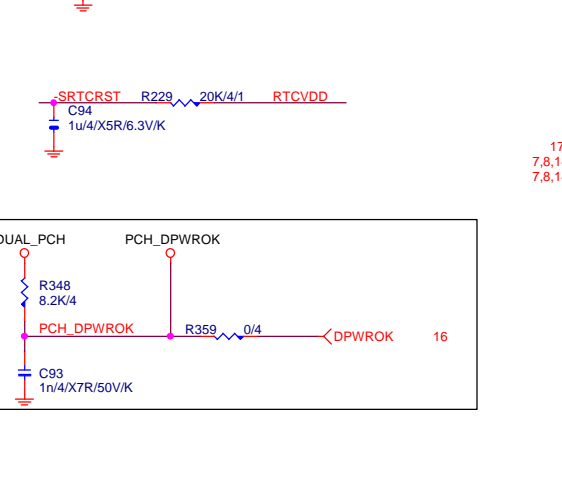
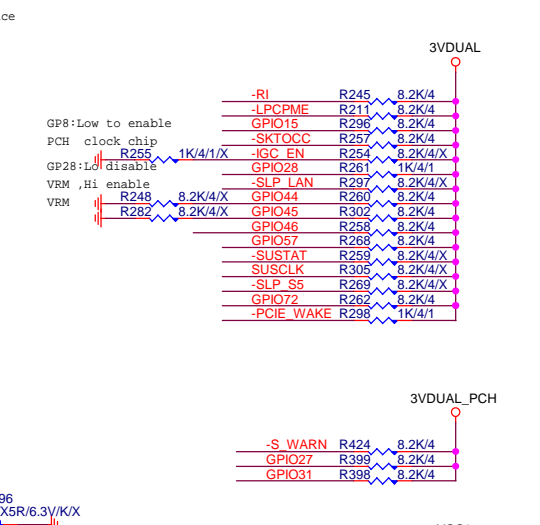
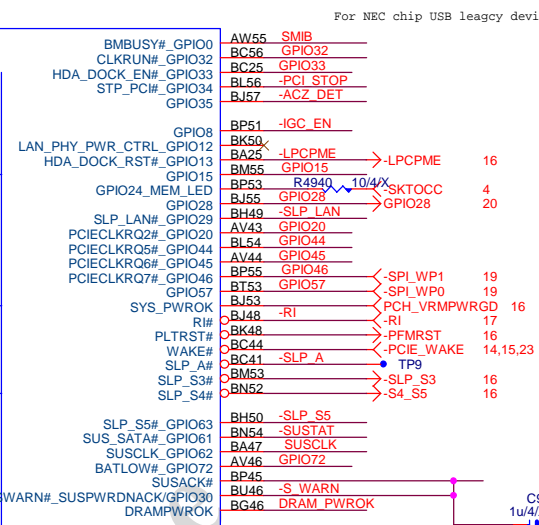
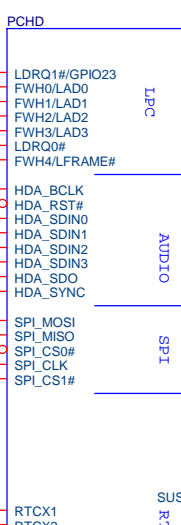
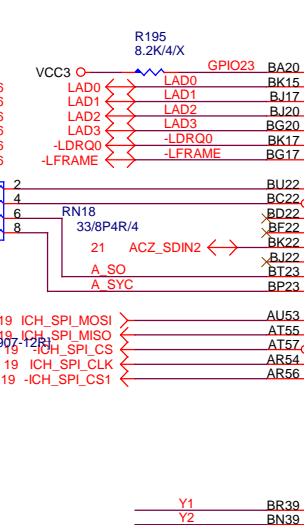
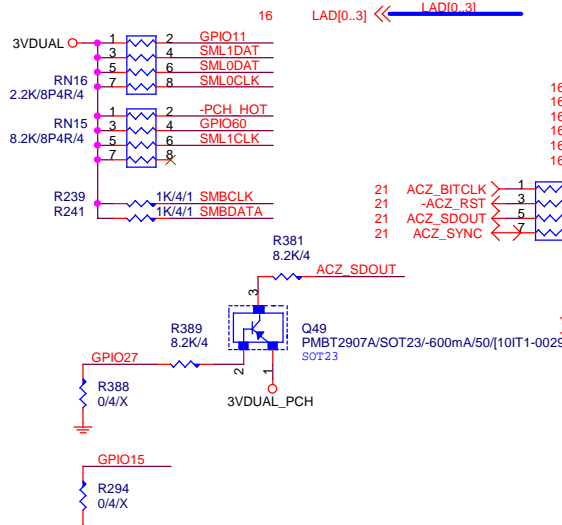

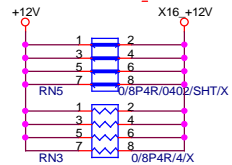
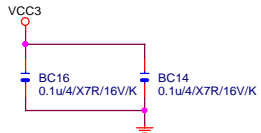

EXP A_RXP0_15I >>> EXP_A_RXP[0..15] 4
EXP A_RXN0_15I >>> EXP_A_RXN[0..15] 4
EXP A_TXP0_15I >>> EXP_A_TXP[0..15] 4
EXP A_TXN0_15I >>> EXP_A_TXN[0..15] 4

EXP A_TXP0	C22	0.22u/4/X5R/6.3V/K	EXP A_TXP0C
EXP A_TXN0	C26	0.22u/4/X5R/6.3V/K	EXP A_TXN0C
EXP A_TXP1	C29	0.22u/4/X5R/6.3V/K	EXP A_TXP1C
EXP A_TXN1	C31	0.22u/4/X5R/6.3V/K	EXP A_TXN1C
EXP A_TXP2	C33	0.22u/4/X5R/6.3V/K	EXP A_TXP2C
EXP A_TXN2	C35	0.22u/4/X5R/6.3V/K	EXP A_TXN2C
EXP A_TXP3	C37	0.22u/4/X5R/6.3V/K	EXP A_TXP3C
EXP A_TXN3	C40	0.22u/4/X5R/6.3V/K	EXP A_TXN3C
EXP A_TXP4	C48	0.22u/4/X5R/6.3V/K	EXP A_TXP4C
EXP A_TXN4	C49	0.22u/4/X5R/6.3V/K	EXP A_TXN4C
EXP A_TXP5	C52	0.22u/4/X5R/6.3V/K	EXP A_TXP5C
EXP A_TXN5	C54	0.22u/4/X5R/6.3V/K	EXP A_TXN5C
EXP A_TXP6	C56	0.22u/4/X5R/6.3V/K	EXP A_TXP6C
EXP A_TXN6	C58	0.22u/4/X5R/6.3V/K	EXP A_TXN6C
EXP A_TXP7	C60	0.22u/4/X5R/6.3V/K	EXP A_TXP7C
EXP A_TXN7	C61	0.22u/4/X5R/6.3V/K	EXP A_TXN7C
EXP A_TXP8	C63	0.22u/4/X5R/6.3V/K	EXP A_TXP8C
EXP A_TXN8	C64	0.22u/4/X5R/6.3V/K	EXP A_TXN8C
EXP A_TXP9	C66	0.22u/4/X5R/6.3V/K	EXP A_TXP9C
EXP A_TXN9	C67	0.22u/4/X5R/6.3V/K	EXP A_TXN9C
EXP A_TXP10	C69	0.22u/4/X5R/6.3V/K	EXP A_TXP10C
EXP A_TXN10	C70	0.22u/4/X5R/6.3V/K	EXP A_TXN10C
EXP A_TXP11	C71	0.22u/4/X5R/6.3V/K	EXP A_TXP11C
EXP A_TXN11	C72	0.22u/4/X5R/6.3V/K	EXP A_TXN11C
EXP A_TXP12	C74	0.22u/4/X5R/6.3V/K	EXP A_TXP12C
EXP A_TXN12	C75	0.22u/4/X5R/6.3V/K	EXP A_TXN12C
EXP A_TXP13	C77	0.22u/4/X5R/6.3V/K	EXP A_TXP13C
EXP A_TXN13	C78	0.22u/4/X5R/6.3V/K	EXP A_TXN13C
EXP A_TXP14	C79	0.22u/4/X5R/6.3V/K	EXP A_TXP14C
EXP A_TXN14	C80	0.22u/4/X5R/6.3V/K	EXP A_TXN14C
EXP A_TXP15	C82	0.22u/4/X5R/6.3V/K	EXP A_TXP15C
EXP A_TXN15	C83	0.22u/4/X5R/6.3V/K	EXP A_TXN15C

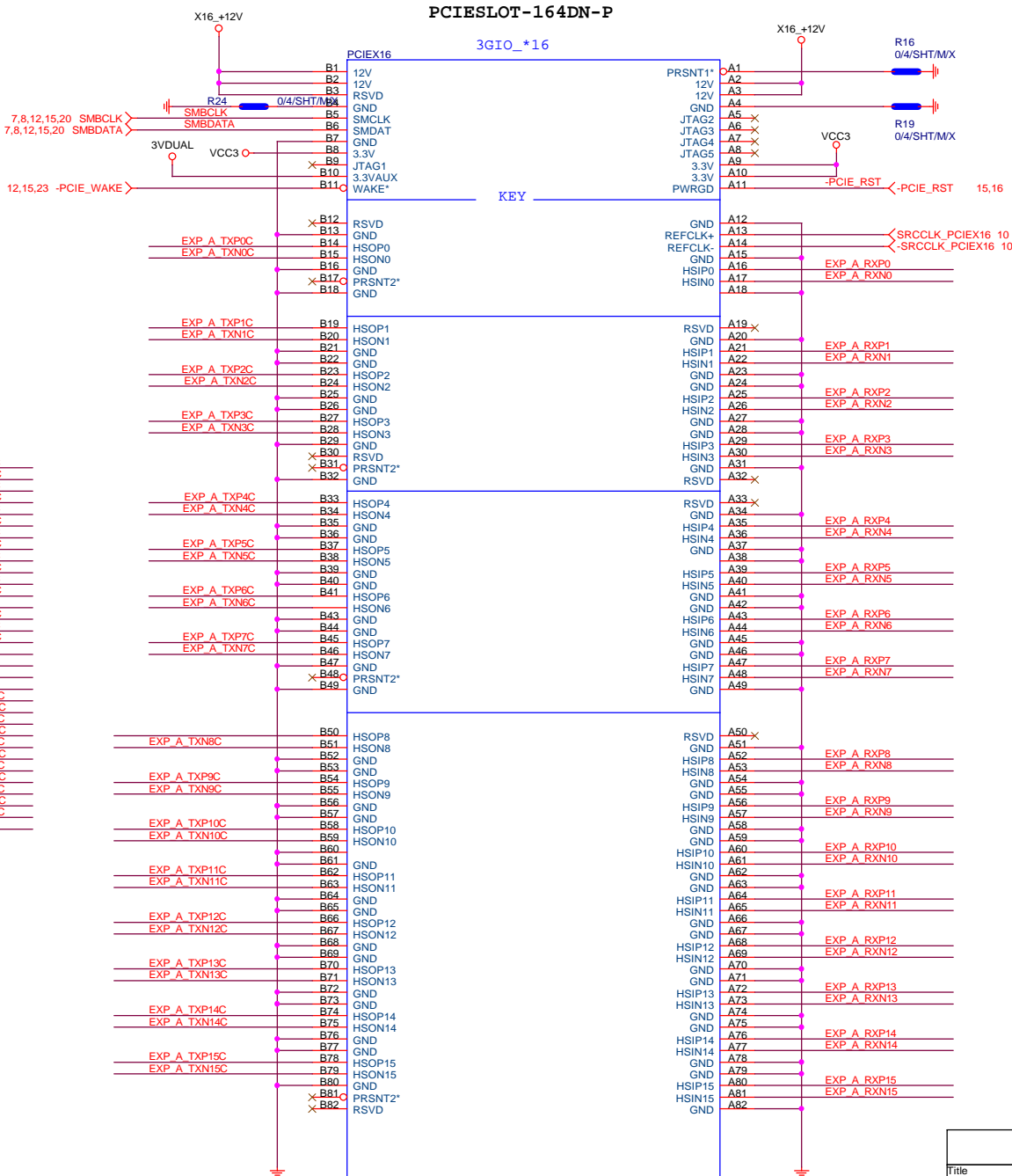

PCI-E/16X-164P/297C/LONG DOUBL

Gigabyte Technology
PCI EXPRESS * 16
Document Number **GA-H61M-DS2** Rev **4.01**
Date: Wednesday, September 25, 2013 Sheet 14 of 30

PCIE*1

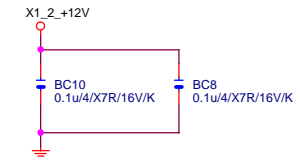
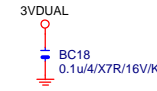
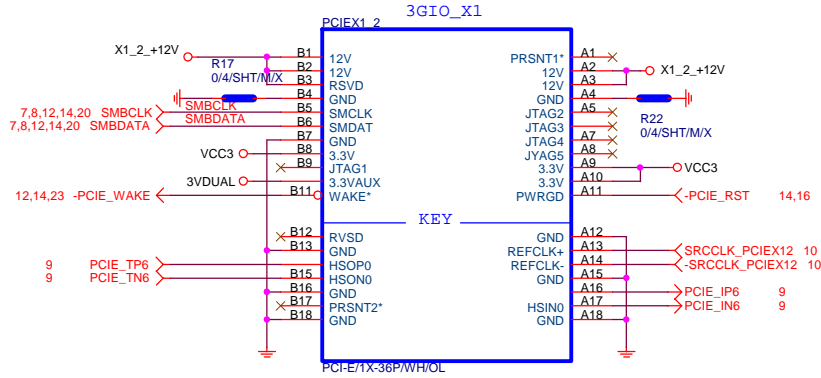
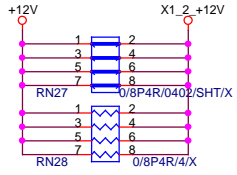
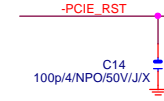
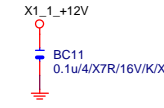
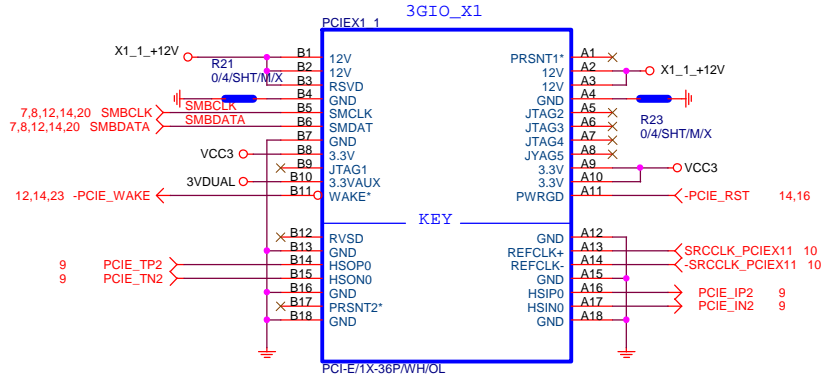
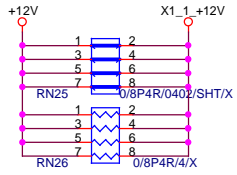

Gigabyte Technology

Title			PCIEX1,X2/CLK GEN	
Size	Document Number	GA-H61M-DS2		Rev
Custom				4.01
Date:	Wednesday, September 25, 2013	Sheet	15	of 30

GP22 Default GP22 DIOD8
GP23 Default CPU_PG DOD8

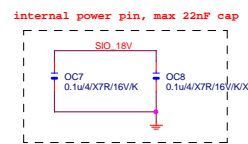
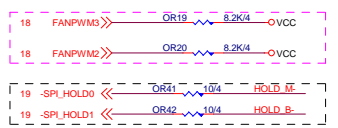
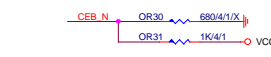
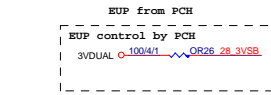
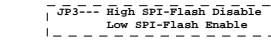
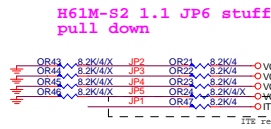
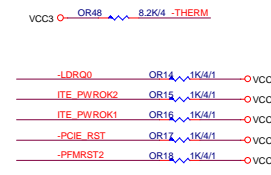
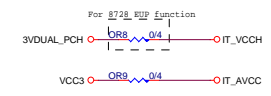
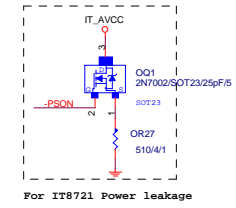
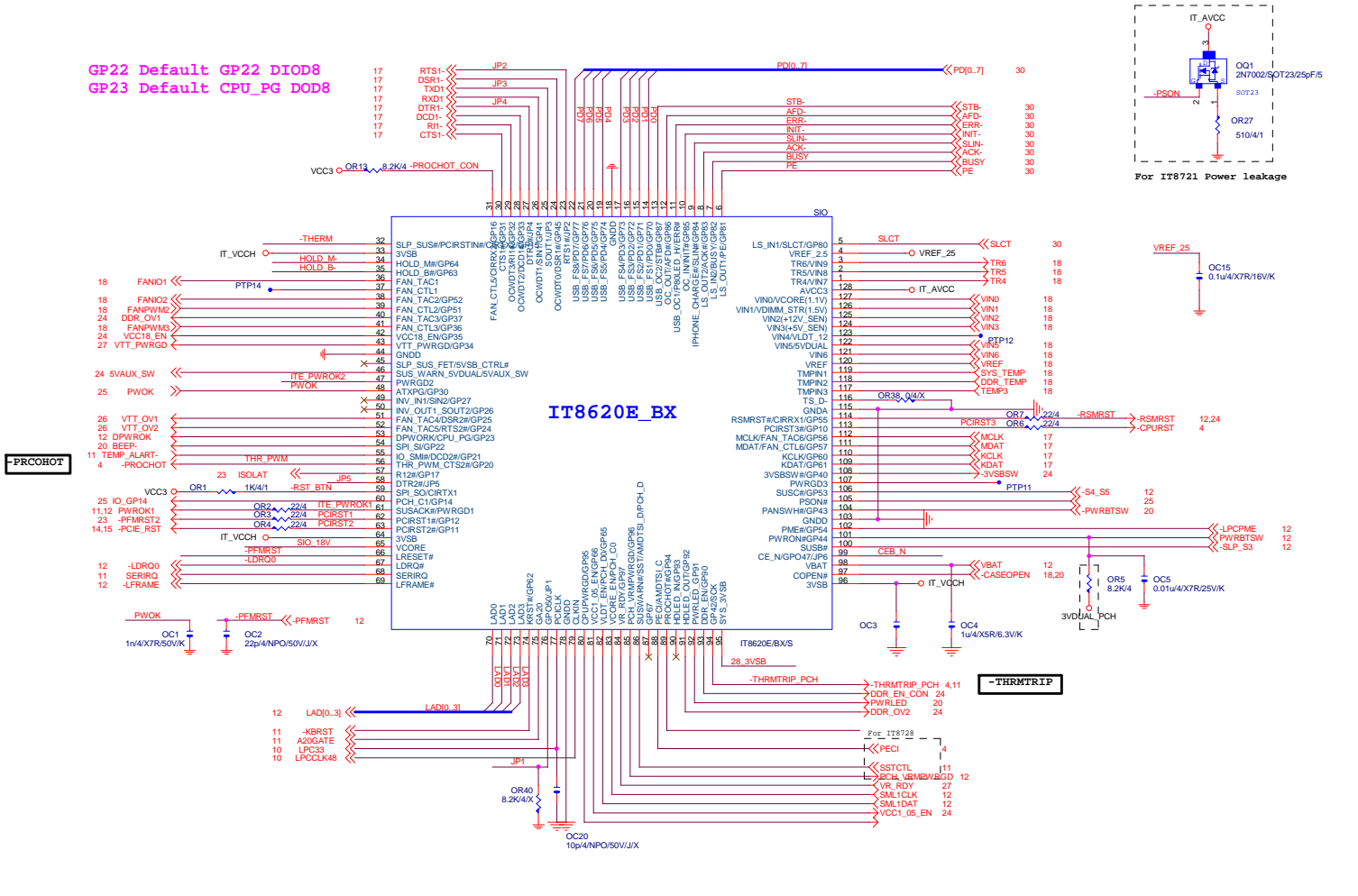

IT8728	
FIN21	VCORE_EN/PCH_C0
FIN20	VLDI_TN/PCH_D0
FIN19	ATXPO
FIN31	PCH_C1
FIN53	SST/AMDTSS1_D/MTR8M/PCH_D1
FIN55	PBC1/AMDTSS1_C/DK9M
FIN66	SYS_3VSB
FIN70	GP47
FIN95	VIN2 (VCC5)
FIN96	VIN1 (VCC12)
FIN97	VIN1_VDIMM_STR(1.5V)
FIN98	VIN0_VCORE(1.1V)/NC

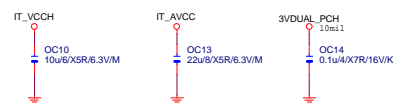

COM

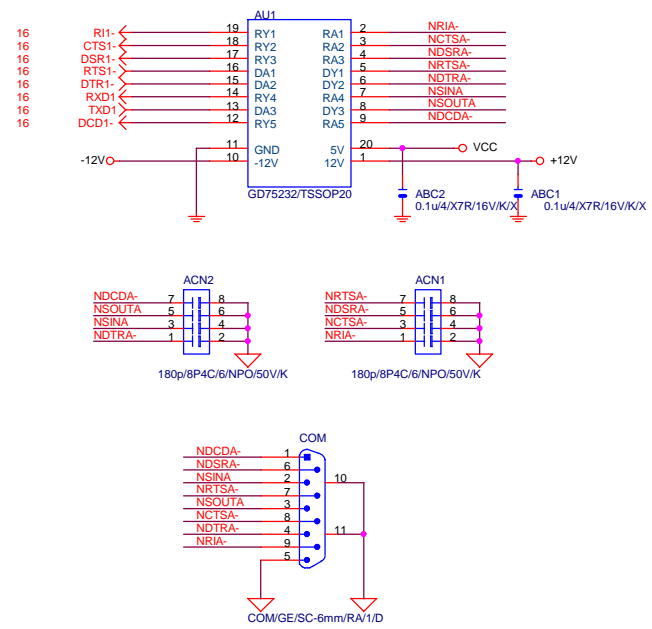

COM RI

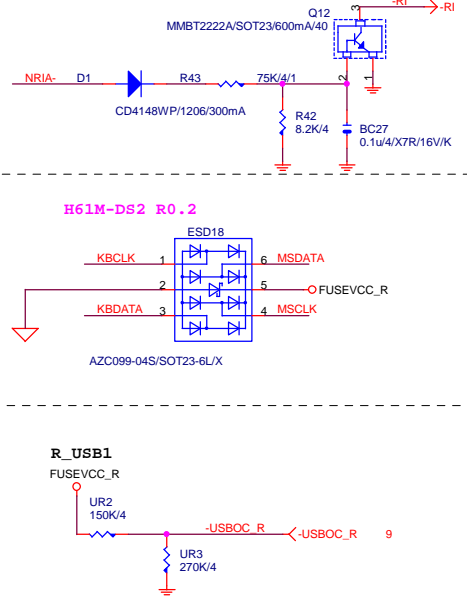

KB/MS

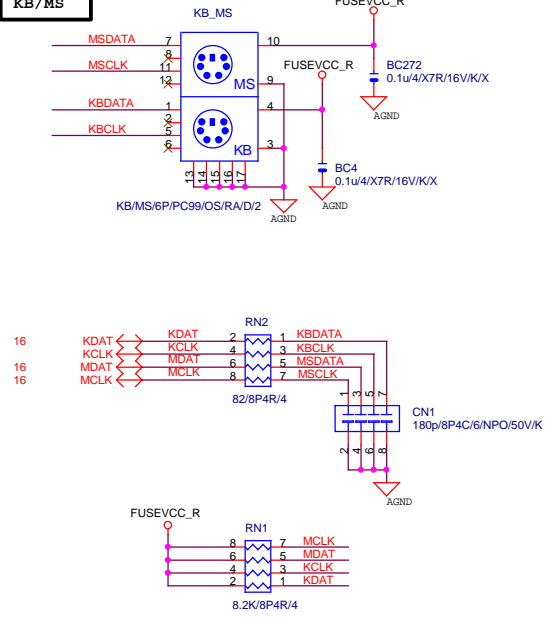

R_USB1

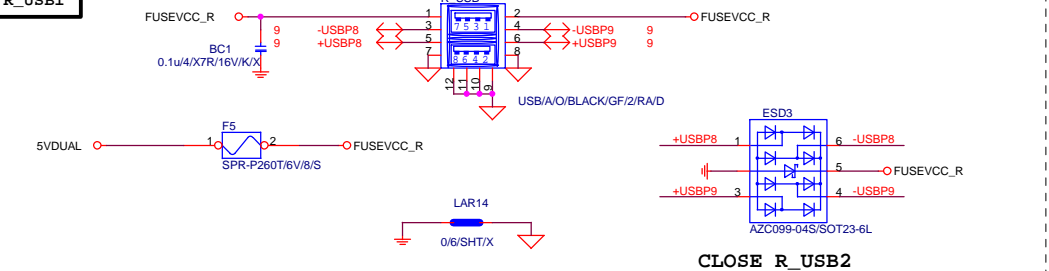

CLOSE R_USB2

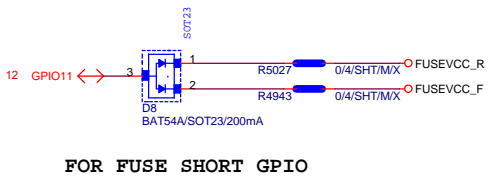

FOR FUSE SHORT GPIO

TEMP H/W MONITOR

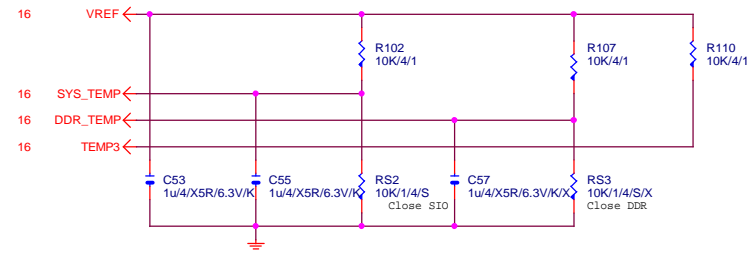

CASE OPEN

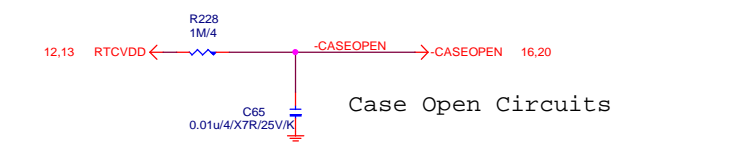

VOLTAGE-- H/W MONITOR

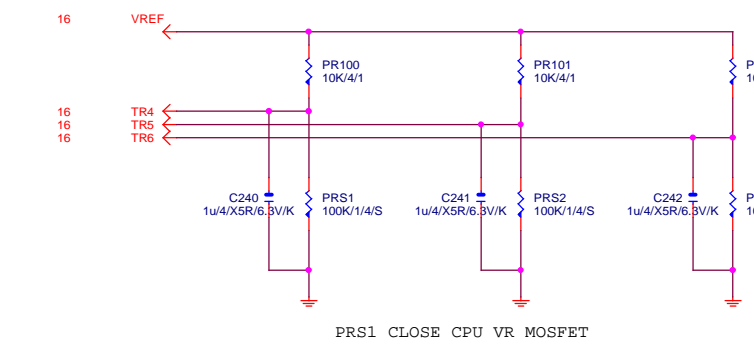
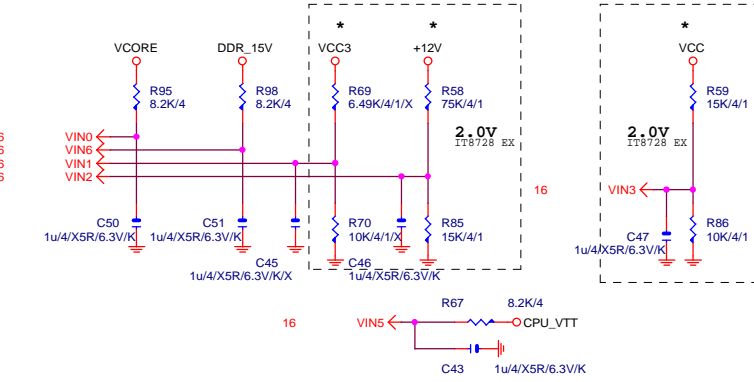

CPU SMART FAN

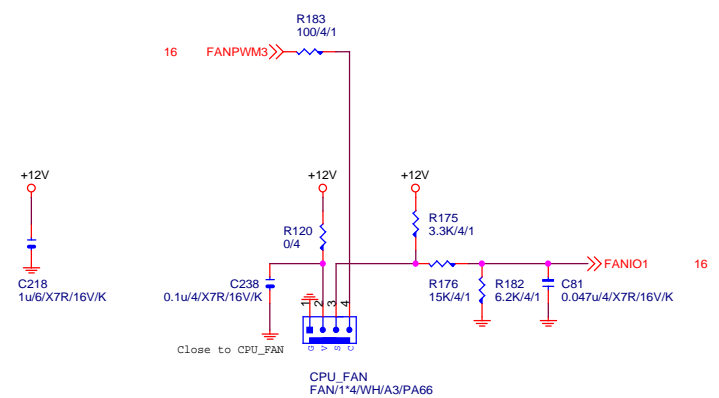

SYS SMART FAN

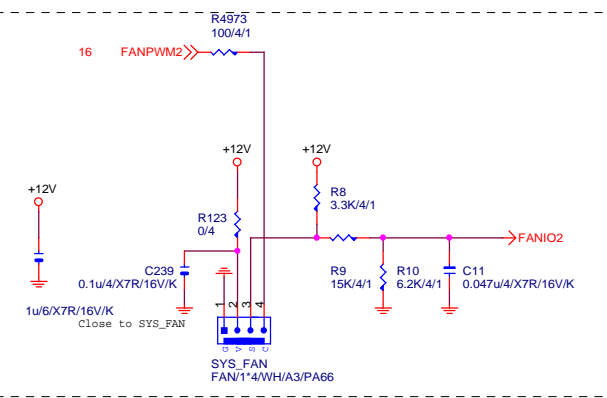

Gigabyte Technology			
Title HWM,FAN CTRL,OV			
Size Custpm	Document Number GA-H61M-DS2	Rev 4.01	
Date:	Wednesday, September 25, 2013	Sheet	18 of 30

DUAL BIOS

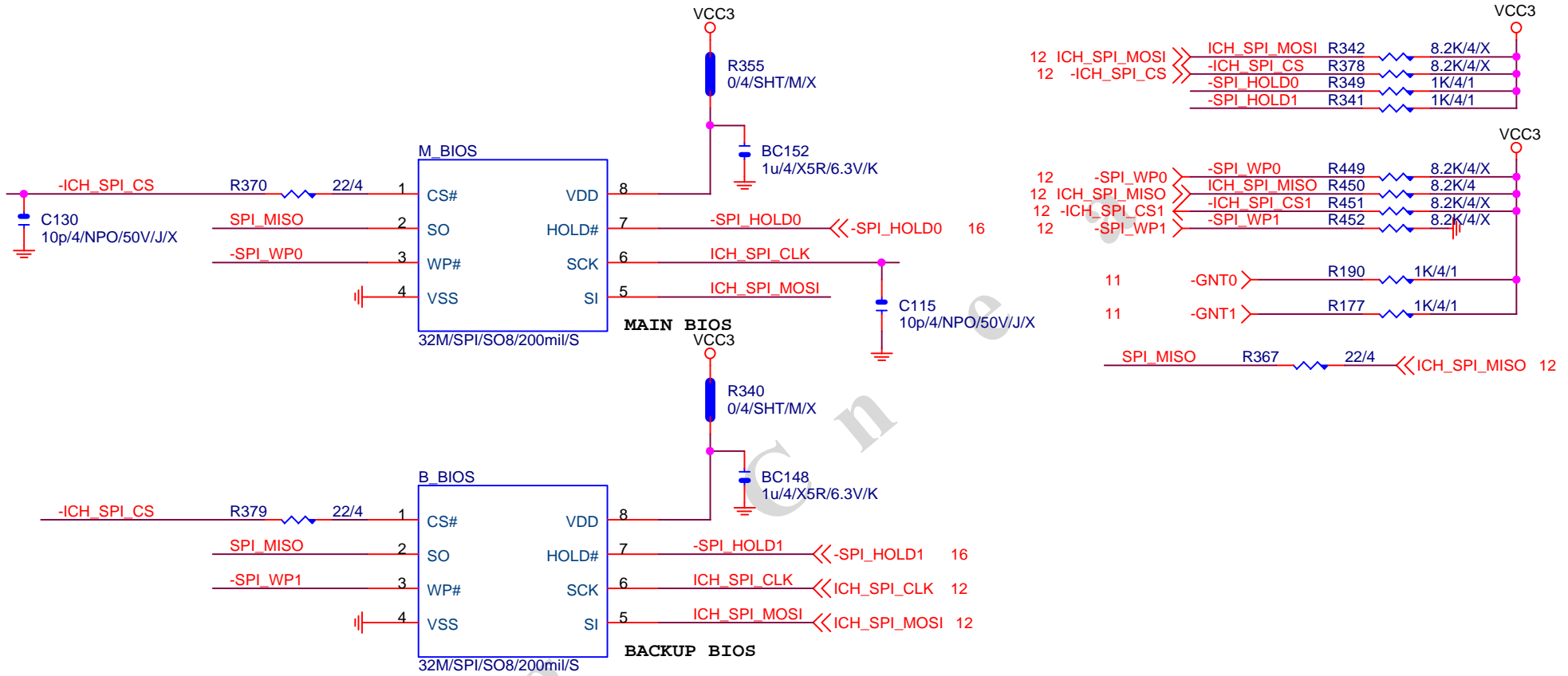

BOOT DEVICE	GNT1	GNT0
LPC	0	0
PCI	0	1
SPI	1	1

1 means floating
0 means PD 1K

Gigabyte Technology

Title		
SINGLE BIOS		
Size A	Document Number	Rev
	GA-H61M-DS2	4.01
Date:	Wednesday, September 25, 2013	Sheet 19 of 30

FRONT USB1

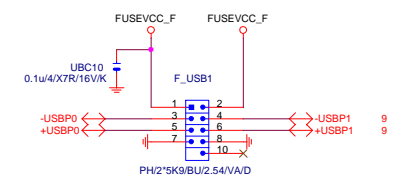

change to BLUE COLOR

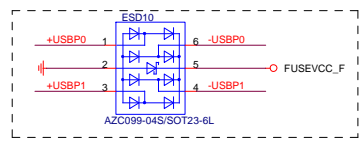

Close to connector

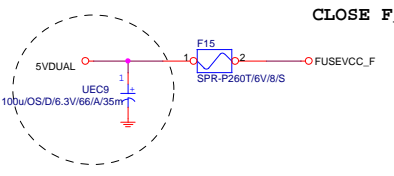

CLOSE F_USB1

FRONT USB2

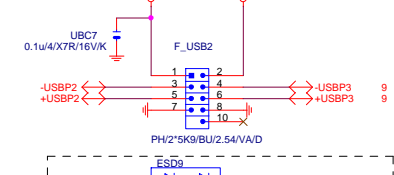

Close to connector

FRONT USB3

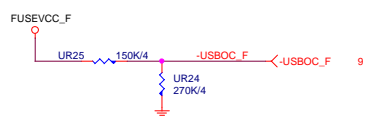

SATA LED



SPKR

RESETCONIN DEFAULT LOW
4sec, 會發BEEP, 故改2N7002

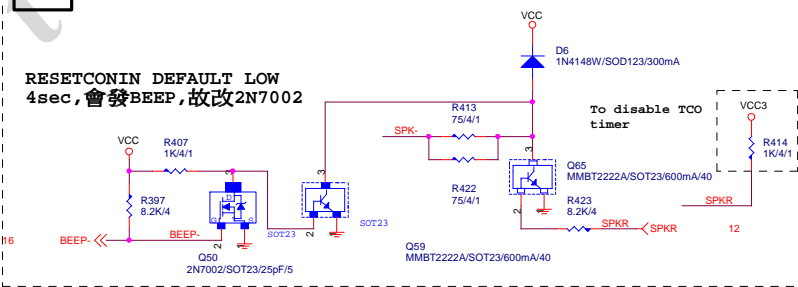

INTEL FRONT PANEL

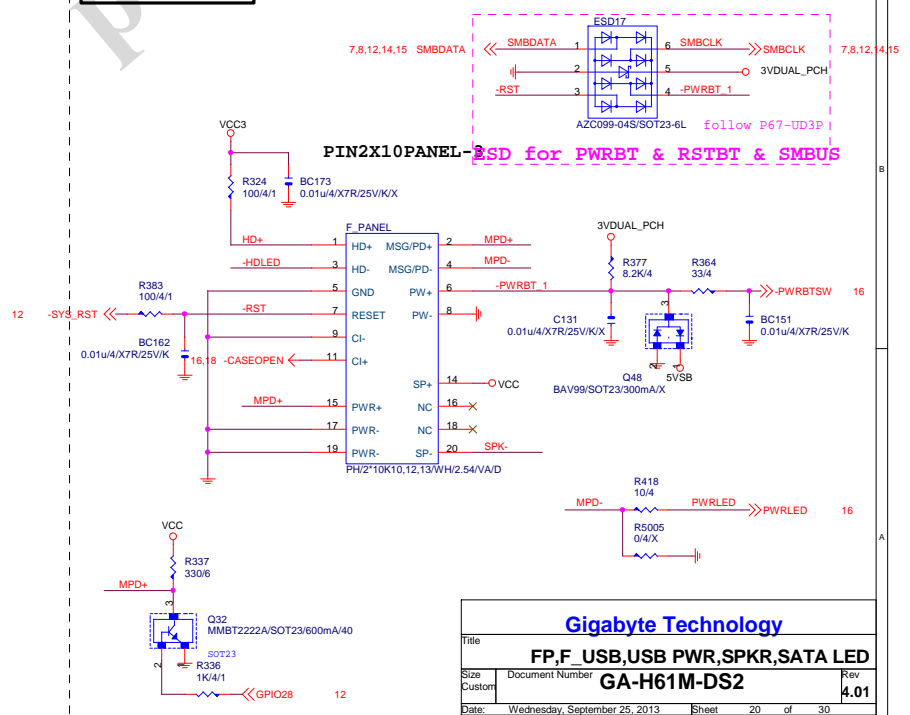

Gigabyte Technology			
Title	FP,F_USB,USB PWR,SPKR,SATA LED		
Size	Document Number	GA-H61M-DS2	
Custom			Rev 4.01
Date:	Wednesday, September 25, 2013	Sheet	20 of 30

	ALC883	ALC888-VA	ALC888B	ALC888-VD	ALC892R	ALC889	ALC889A
CR46	X	X	X	X	X	X	O
CR57	X	X	X	X	X	X	O
CR49	O	O	X	X	X	O	O
CBC40	X	X	X	10uF/X5R	10uF/X5R	X	X
CR20	O	X	X	X	X	X	X
CR26	20K/1%	20K/1%	20K/1%	20K/1%	20K/1%	20K/1%	20K/0.1%
CR47	X	X	O	X	O	O	X
CR48	O	O	X	O	X	X	O
CBC2/CBC4/CBC5/CBC6/CBC10/CBC11	4.7uF/X5R	4.7uF/X5R	4.7uF/X5R	4.7uF/X5R	4.7uF/X5R	10uF/X5R	4.7uF/X5R
CR1/CR3/CR10/CR12/CR15/CR19/CR56/CR27/CR55/CR37/CR28/CR34/CR6/CR9/CR51/CR61	75 ohm	75 ohm	75 ohm	75 ohm	75 ohm	66 ohm or lower	75 ohm
CR66/CR68/CD3/CBC41	X	X	X	O	X	X	X
CR67/CD1/CD2/CQ3/CQ5	O	O	O	X	O	O	O

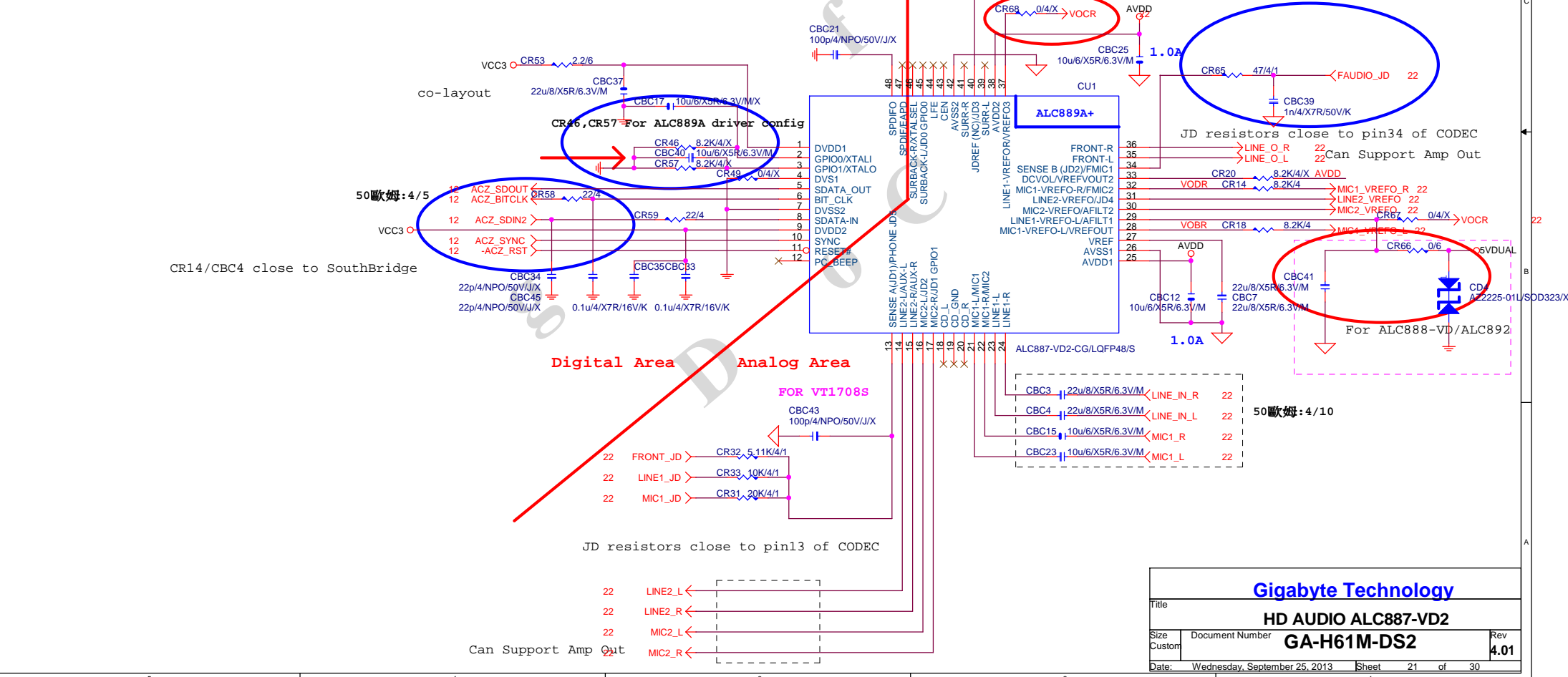

Gigabyte Technology

HD AUDIO ALC887-VD2

Size: Document Number **GA-H61M-DS2** Rev **4.01**

Date: Wednesday, September 25, 2013 Sheet 21 of 30

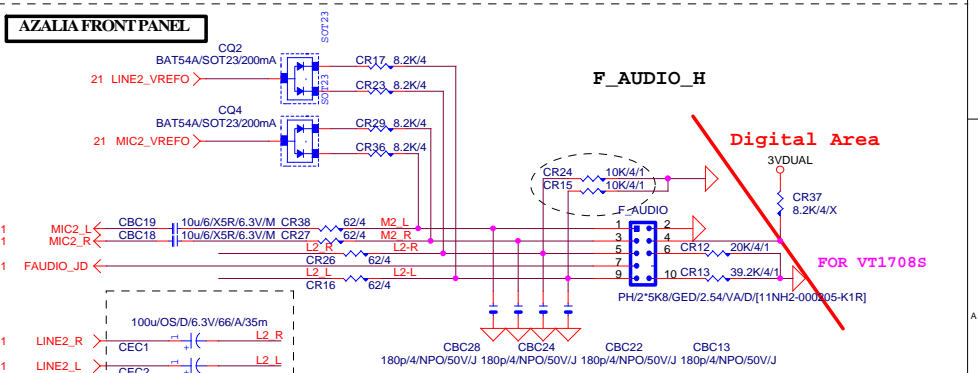
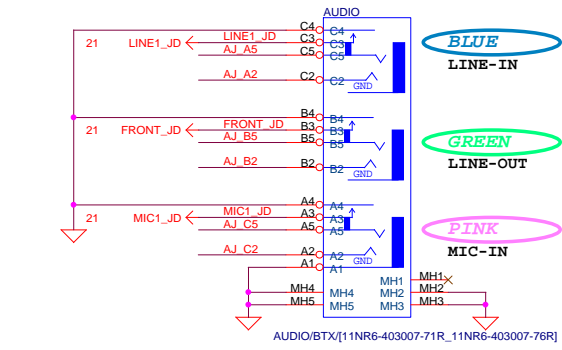
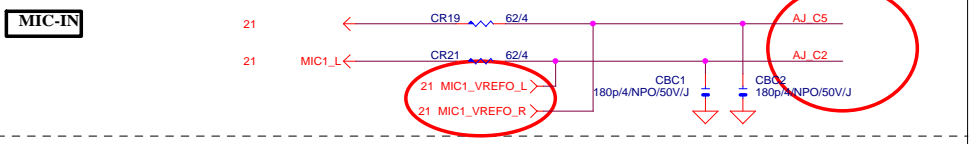
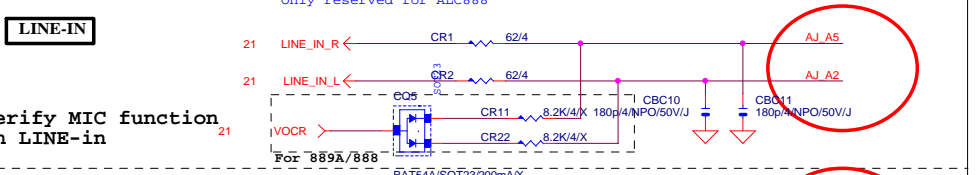
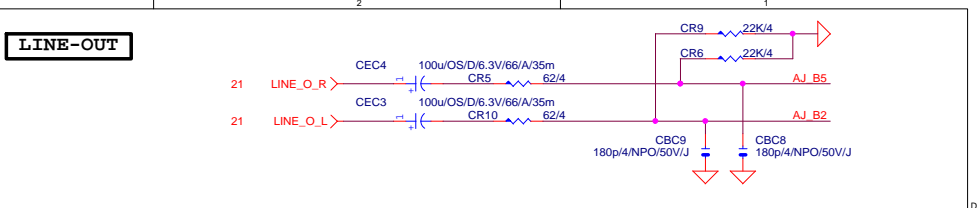
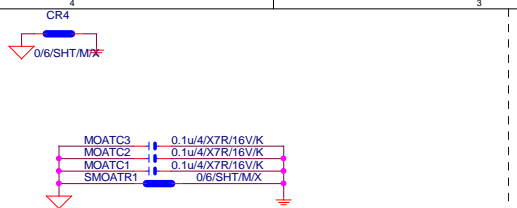
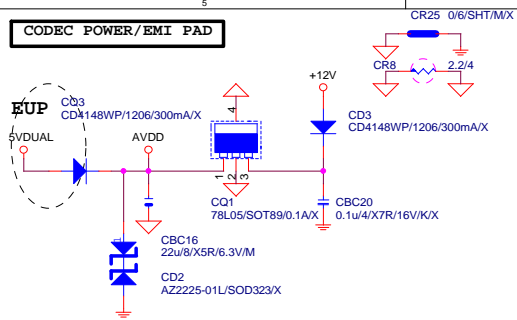

Gigabyte Technology		
Title		
AUDIO JACK		
Size	Document Number	Rev
Custom	GA-H61M-DS2	4.01
Date:	Wednesday, September 25, 2013	Sheet 22 of 30

LAN:RTL8111E/VB/VL

SCH BOM OPT: (二擇一使用)
 --> (LAR11) :M/B有CLK GEN 25M
 --> (LAX1, LAC5, LAC6) :M/B無CLK GEN 25M

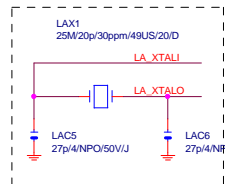
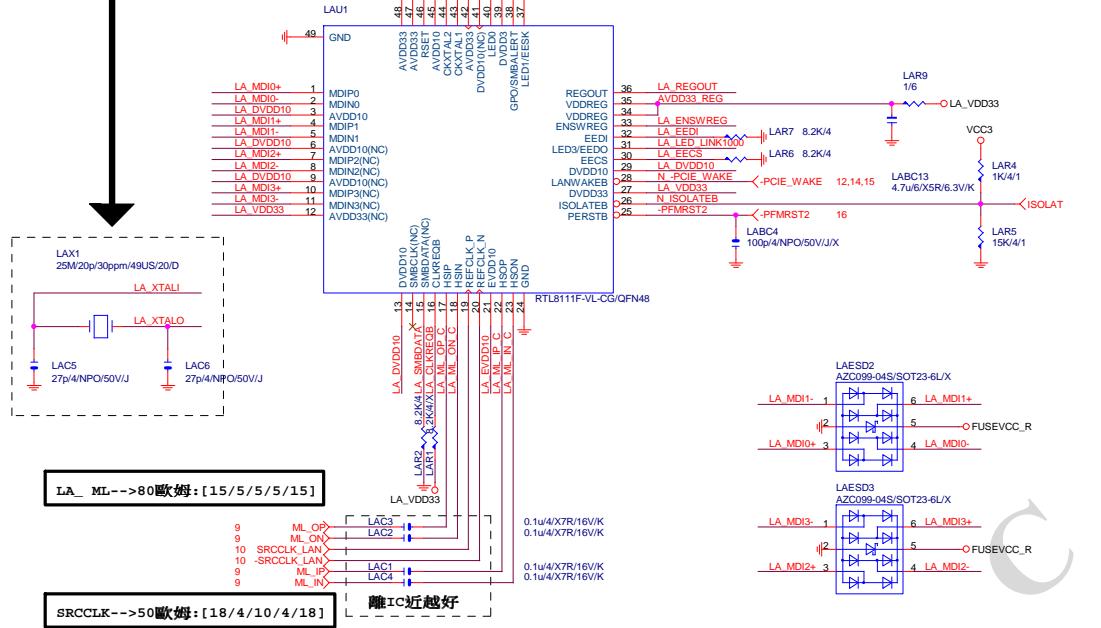

LA_ML-->80歐姆:[15/5/5/15]

SRCLK-->50歐姆:[18/4/10/4/18]

USB LAN CONNECTOR

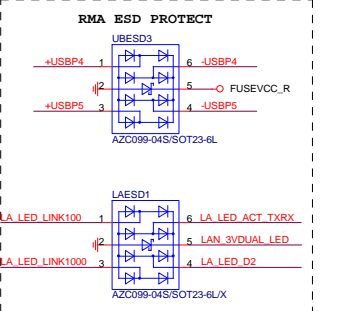

注意:LAN LED PROTECT:(CO-LAYOUT)
 1. ESD (6PIN):AOZ8902CIL/SOT23-6(DEFAULT)
 2. SURGE (5PIN):AZ2025-04S/SOT23-5L

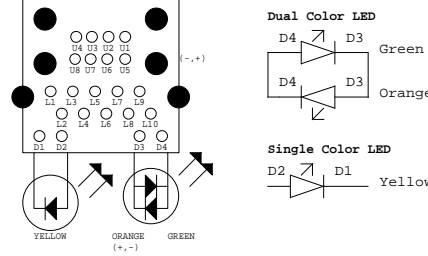

LA_MDI-->100歐姆:[20/4/8/4/20]

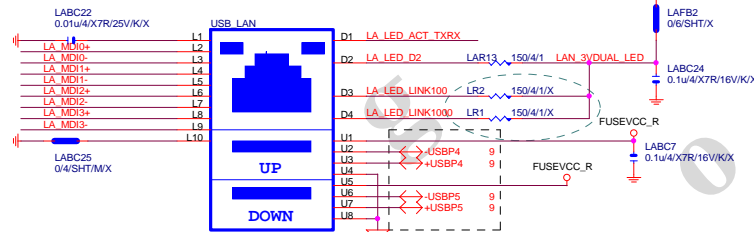

注意:USB PORT(目前:暫代6,7PORT)
 USB-->90歐姆:[15/4.5/7.5/4.5/15]

料號	規格	廠商
11NR6-702009-0ER	1G LAN (12core)	UDE
11NR6-702009-91R	1G LAN (8 core)	FOXCONN
11NR6-702009-92R	1G LAN (8 core)	UDE
11NR6-702009-11R	1G LAN (12core/RED)	UDE
11NR6-702009-12R	1G LAN (8 core/RED)	FOXCONN

USB LAN BOM區分:
 1. (紅色/12CORE/三倍):USB+LAN/1G/GO,Y/OS/RA/D/1/RED
 2. (黑色/12CORE):USB+LAN/1G/GO,Y/OS/RA/D/1
 3. (黑色/8CORE):USB+LAN/1G/GO,Y/OS/RA/D/8C

LAN POWER

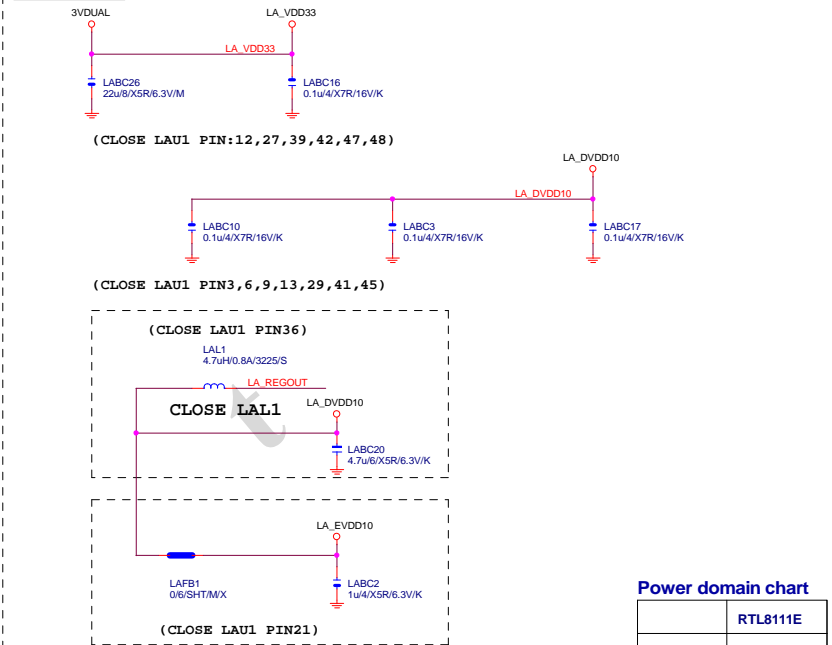

Power domain chart

	RTL8111E
AVDD33	3.3V
DVDD33	3.3V
VDDREG	3.3V
DVDD10	1.05V

USB X3 POWER

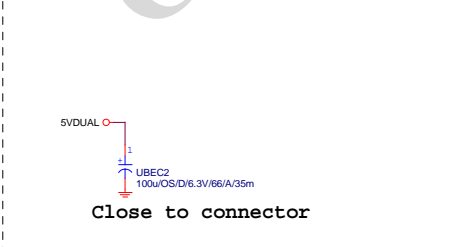

Close to connector

USB OC/FUSE PROTECT

EMI SHORT PAD

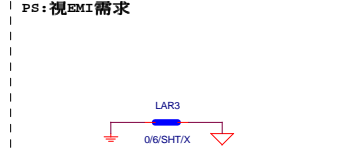

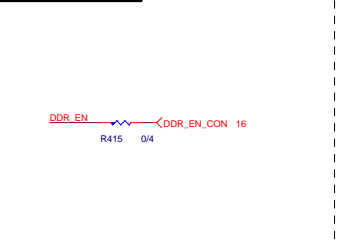
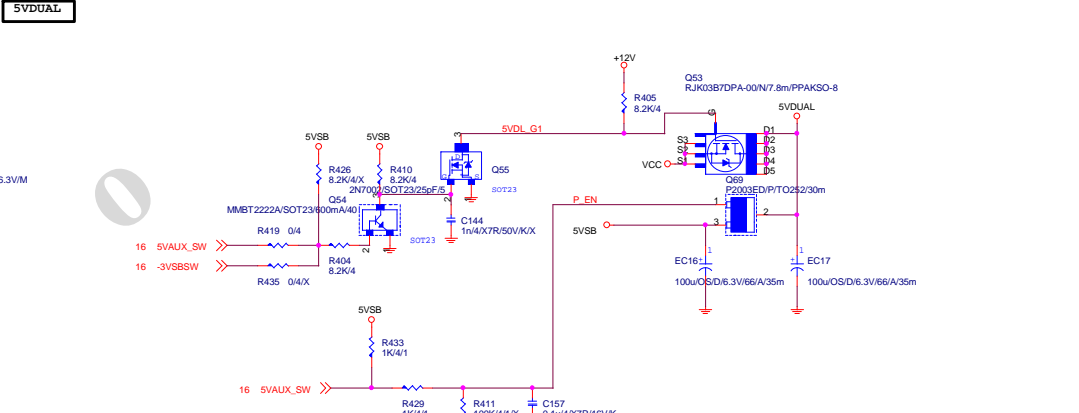
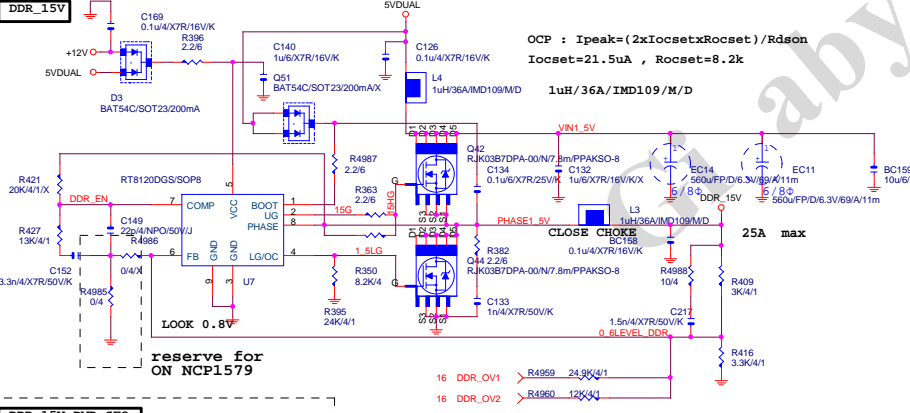
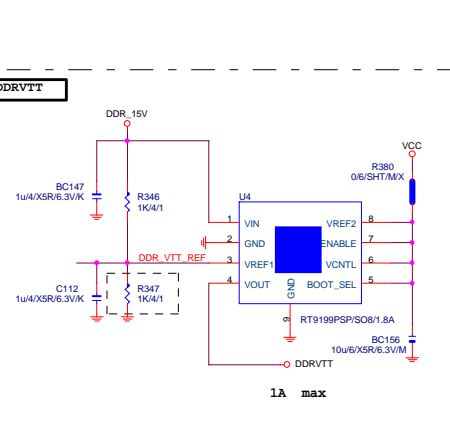
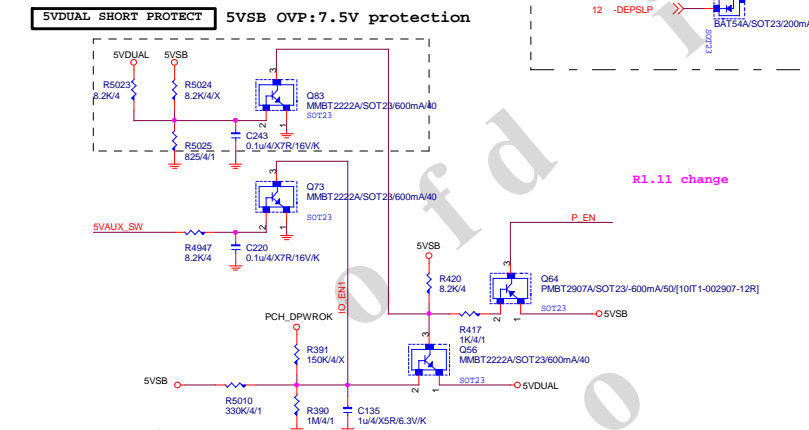
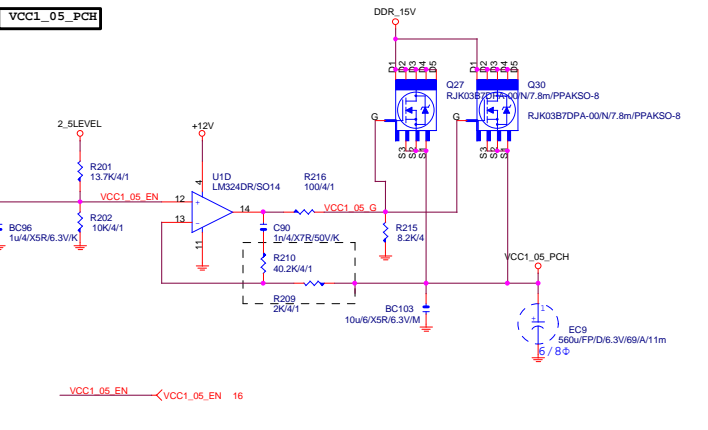
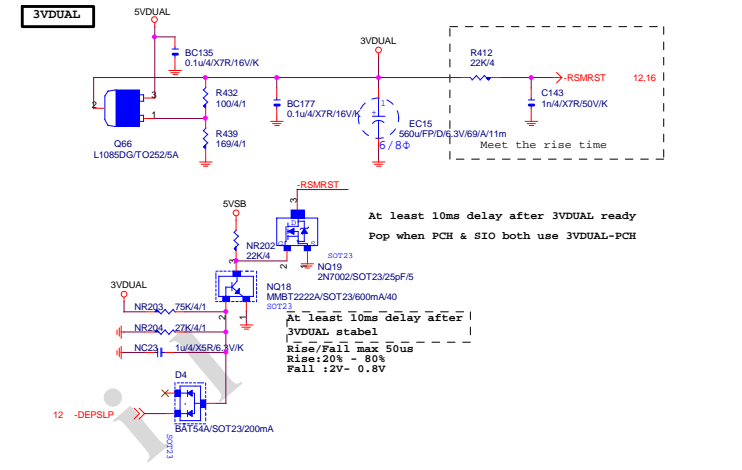
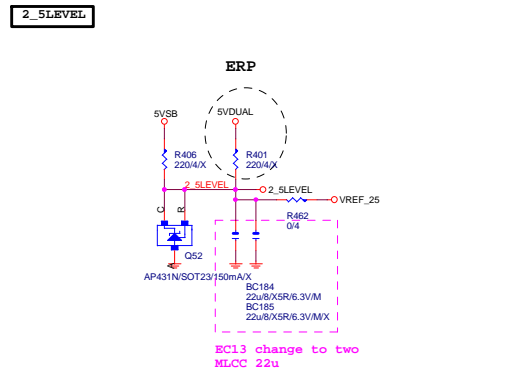
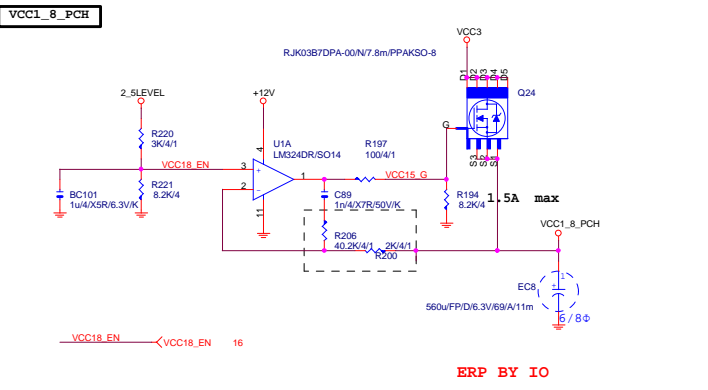

Gigabyte Technology			
File	DISCRETE POWER		
Size	Document Number	GA-H61M-DS2	
C			Rev 4.01
Date:	Wednesday, September 25, 2013	Sheet	24 of 30

ATXX24 POWER CONNECTOR

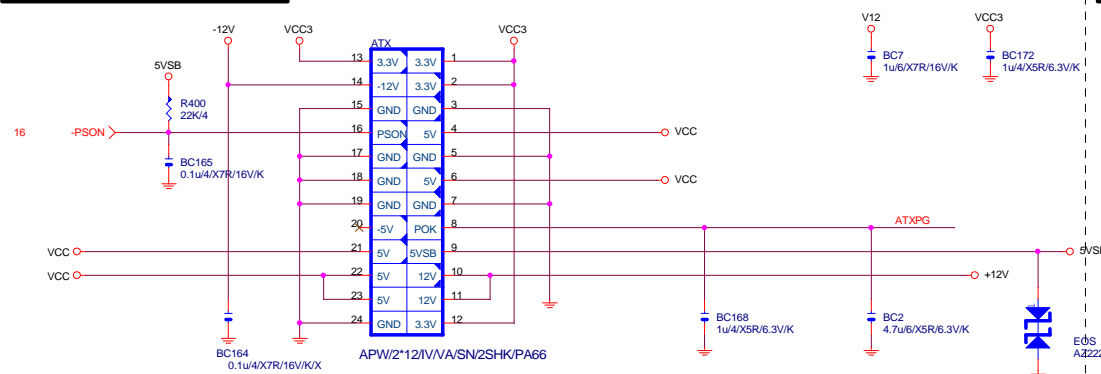

ATXX4 POWER CONNECTOR

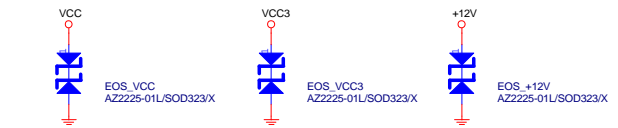
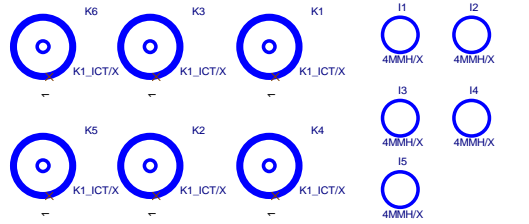
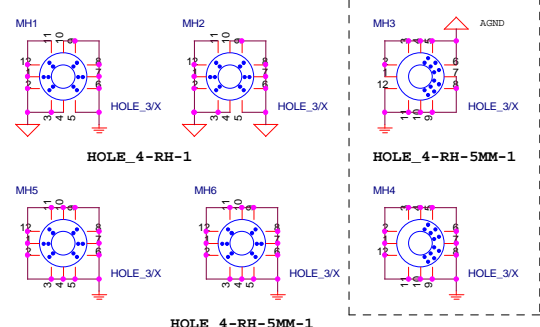
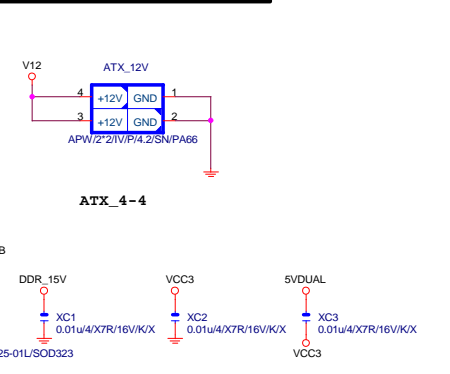

To prevent the 5VSB under loading when boot

5VDUAL1 (USB PORT/DDRIII POWER)
5VDUAL (3VDUAL/OTHER)

-S_WARN-->5VDUAL1-->-S_ACK (PCH)-->-DEPSLP/-RSMRST-->5VDUAL-->3VDUAL

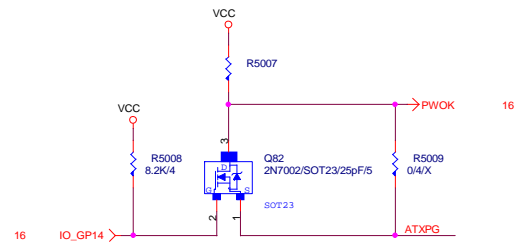

【技術通報R&D技術通報153】
To fix 12V light load abnormal issue

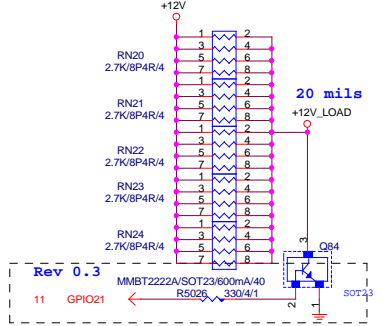

CPU_VTT

VTT_EN	
HI	ENABLE
LO	DISABLE

VTT OV option



VCCSA

PDG 0.8

VSA_SEL	
HI	0.85V
LO	0.925V

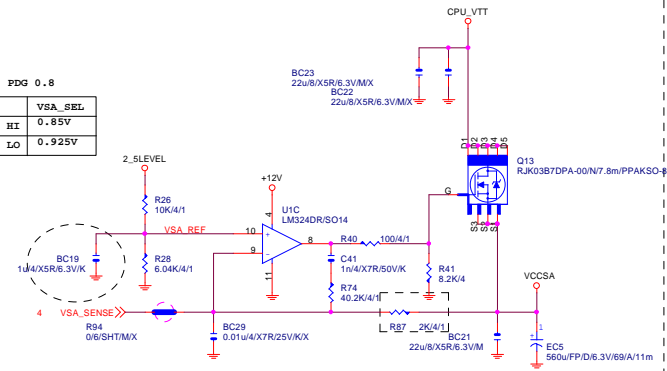

VCCSA PWR SEQ

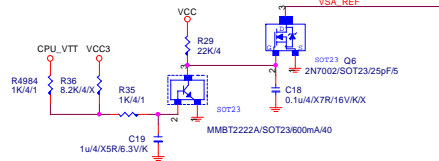

CPU_VTT PWR SEQ

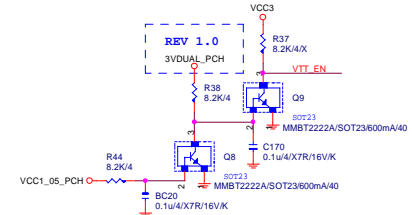

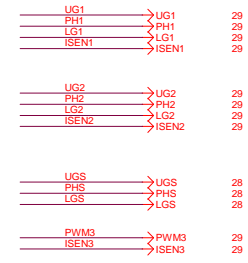
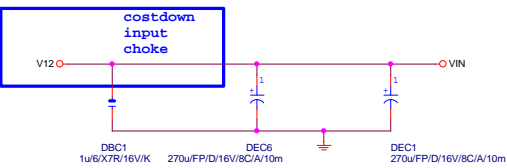
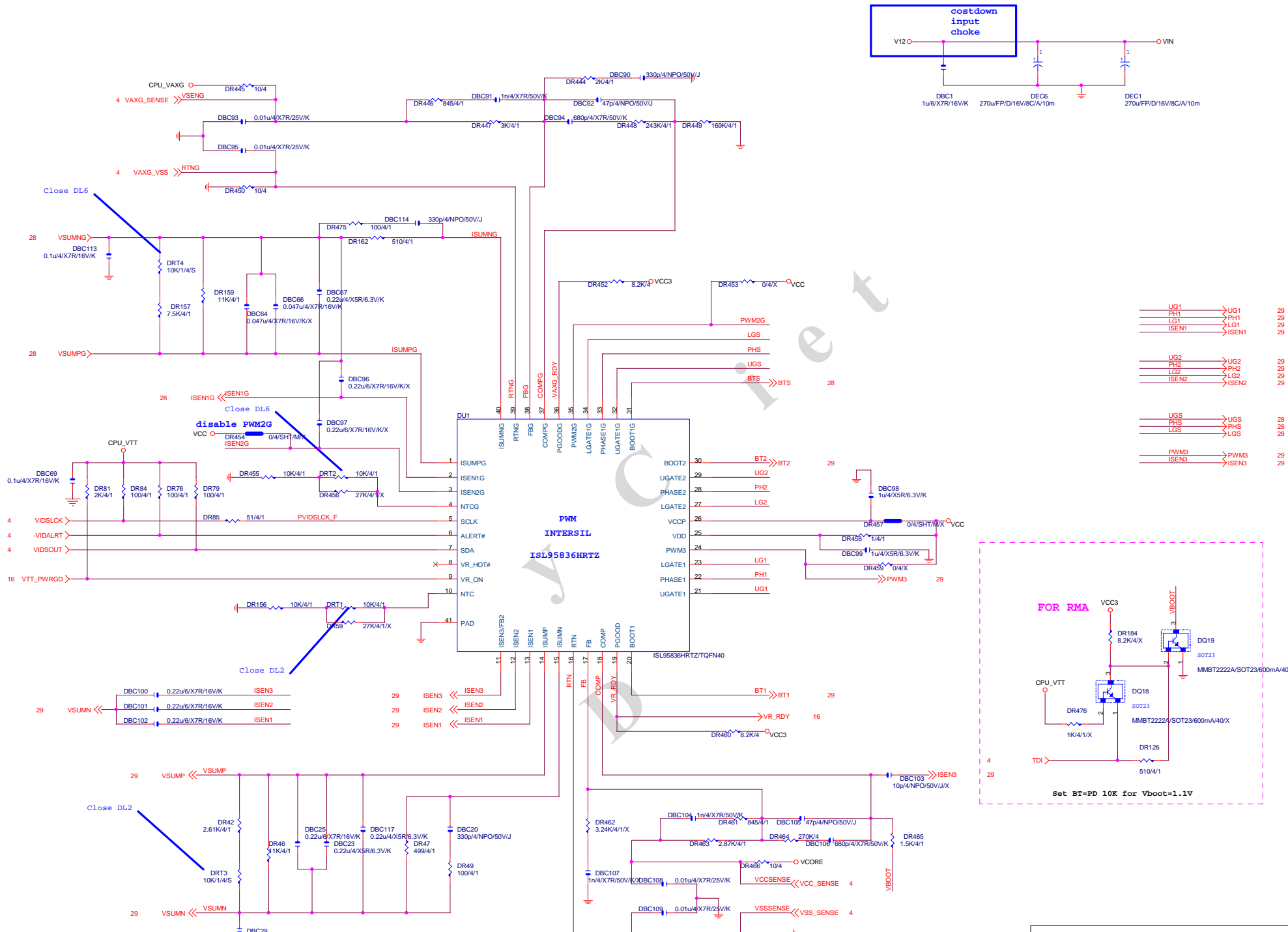

PWM
INTERSIL
ISL9583HRTZ

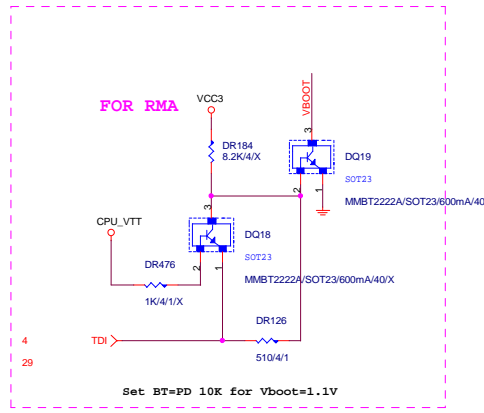

**BOTTOM PAD
CONNECT TO
GND
THROUGH 10
VIA**

Gigabyte Technology		
Title	CPU CORE VR-1	
Size	Document Number	Rev
Custom	GA-H61M-DS2	4.01
Date:	Wednesday, September 25, 2013	Sheet 27 of 30

VAXG

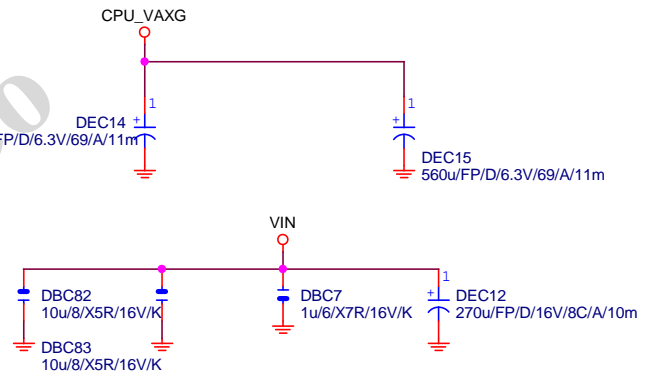
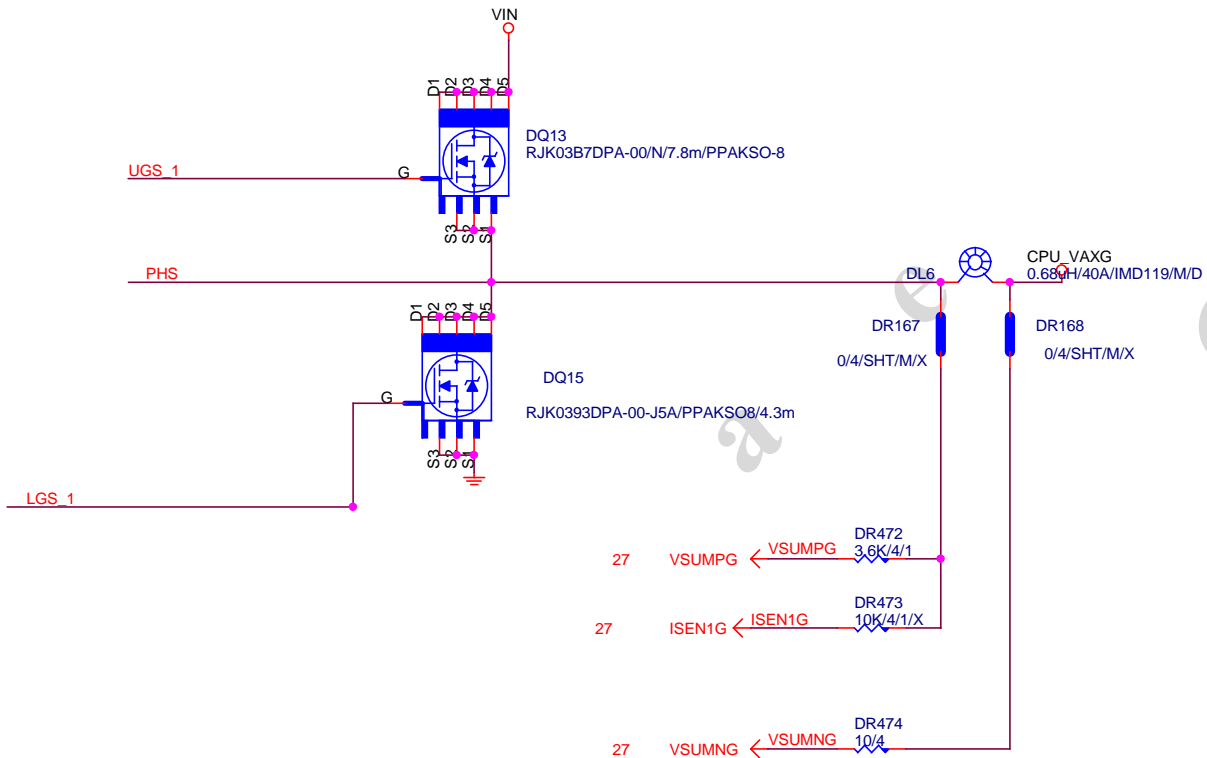
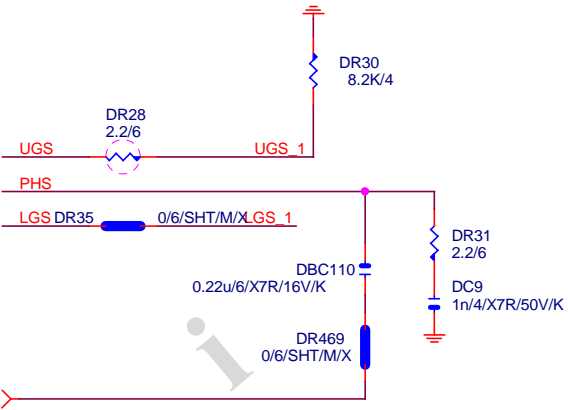
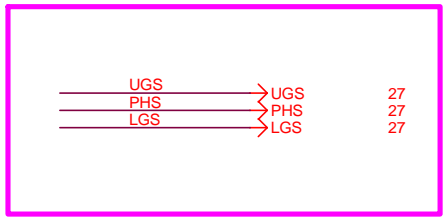

Gigabyte Technology		
Title CPU CORE VR-2		
Size Custom	Document Number GA-H61M-DS2	Rev 4.01
Date:	Wednesday, September 25, 2013	Sheet 28 of 30

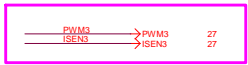
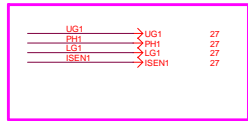

Pop 1S16625CB for PBT
[1S16625CBZ/908]

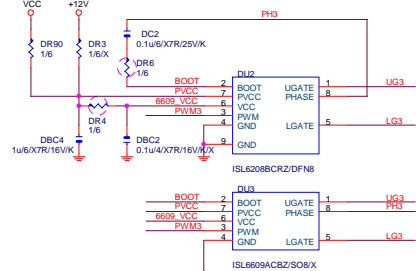

6609 colay with 6208

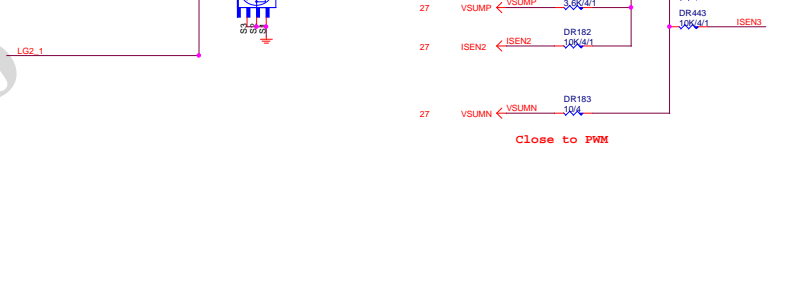
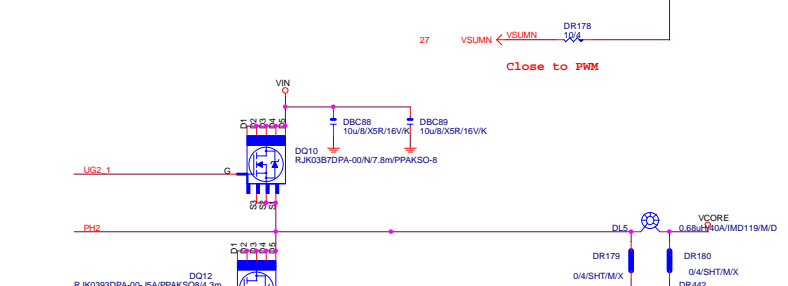
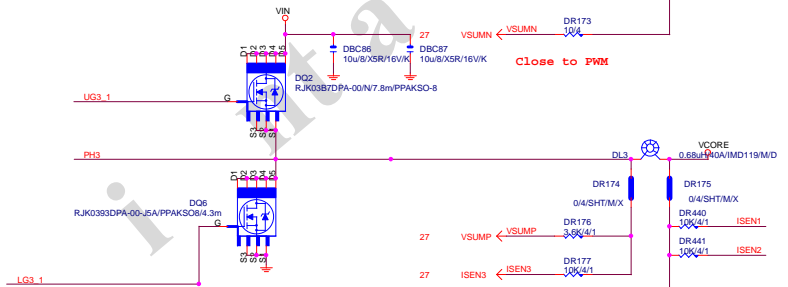
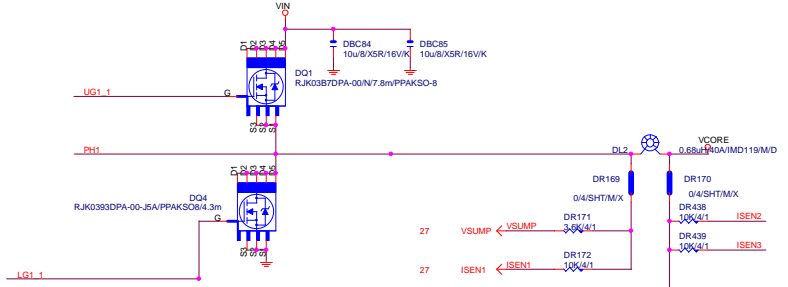
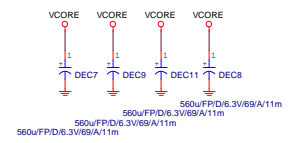
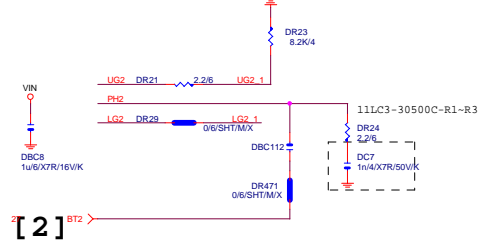
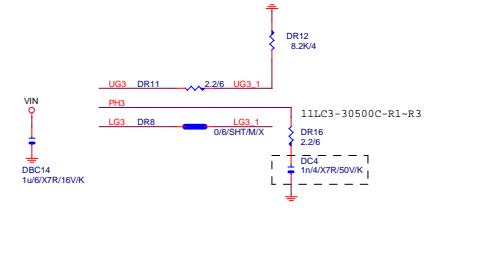
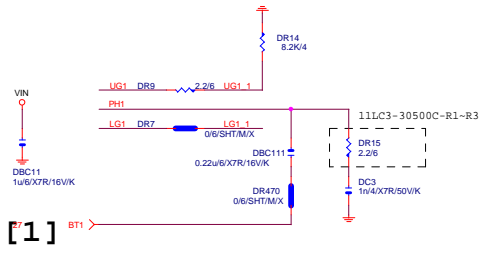
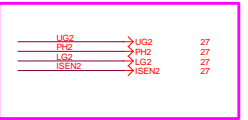

Gigabyte Technology

File		CPU CORE VR-3	
Size	Document Number	GA-H61M-DS2	
Custom			Rev 4.01
Date:	Wednesday, September 25, 2013	Sheet	29 of 30

LPT PORT

