

Model Name: GA-H61M-DS2

Revision 2.01

SHEET TITLE

SHEET TITLE

01	COVER SHEET
02	BOM & PCB MODIFY HISTORY
03	BLOCK DIAGRAM
04	CPU_LGA1155-A
05	CPU_LGA1155-B
06	CPU_LGA1155-C
07	DDR III CHANNEL A
08	DDR III CHANNEL B
09	PCH_FDI,DMI,USB,PCIE,NVRAM
10	PCH_DP,CLK BUFFER
11	PCH_HOST,SATA,PCI
12	PCH_GPIO,CTRL,AUDIO
13	PCH_PWR,GND
14	PCI EXPRESS*16 SLOT
15	PCI EXPRESS*1x2 SLOT
16	ITE 8728 LPC IO
17	COMA,KB_MS,R_USB,-PROCHOT
18	HWM,FAN CTRL,OV
19	DUAL BIOS
20	FP,FUSB,SPK,SATALED
21	ALC887
22	REAR AUDIO JACK
23	REALTEK 8111E/USB_LAN
24	DISCRETE POWER
25	ATX,-S_WARN,-S_ACK,5VDUAL
26	Richtek_RT8120_CPU_VTT
27	VCORE INTERSIL_95836_1

28	VCORE INTERSIL_95836_2
29	VCORE INTERSIL_95836_3
30	LPT

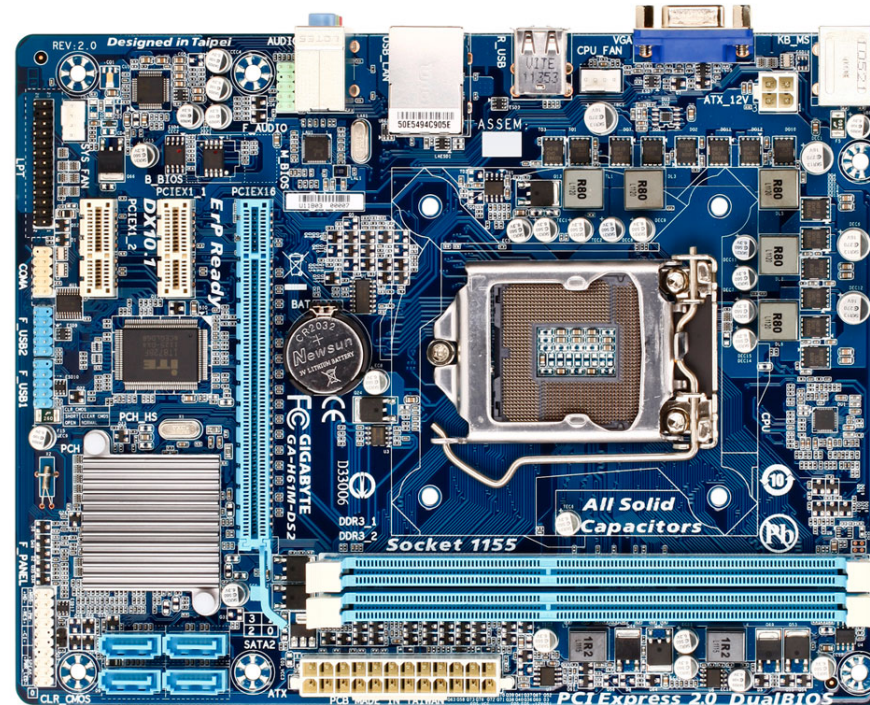

Gigabyte Technology		
Title	Cover Sheet	
Size	Document Number	Rev
Custom	GA-H61M-DS2	2.01
Date:	Wednesday, November 30, 2011	Sheet 1 of 30

Model Name: GA-H61M-DS2

Revision 2.01

Component value change history

2011/11/30

Data	Change Item	Reason
2011.08.22	9MH61MDS2-00-12A	H61M-DS2 R1.2 BOM first release
	remove BC35 & BC34 change to 0.lu fix SIO 8728 factory issue	
	some CAP change to Japan's os-con & adjust loadline	
	add second source ON-MOSFET for VRM	
2011.09.08	9MH61MDS2-00-12B	
	costdown BOM	
2011.10.31	9MH61MDS2-00-12C	
	MOSFET change to 9+6 solution	
2011.11.16	9MH61MDS2-00-12D	
	PWM change to ISL95836	
	DDR & CPU_VTT PWM change to RT8120DGSP	
2011.11.16	9MH61MDS2-00-20A	
	costdown sequence , VTT_SEL & VSA_SEL circuit	
	9MH61MDS2-00-20B	
	LAN change to RTL8111F-VL	
	remove R37 to fix CPU_VTT no Voltage ready	
	9MH61MDS2-00-20C	
	TR68 & R416 changet to 3.3K fix Voltage level	
	add BC165 fix STR issue	
	9MH61MDS2-00-20D	
	fix frequency down issue & change to PBOM	
	9MH61MDS2-00-20E	
	TR68 change to 3K adjust CPU_VTT Voltage level	
	9MH61MDS2-00-20F	

Circuit or PCB layout change

DATE	Change Item	Reason
2011.08.16	H61M-DS2 R1.2 gerber out	
	add LAR14 shortpin short R_USB AGND & DGND	
2011.09.07	H61M-DS2 R1.21 gerber out	
	PWM change to ISL95836	
	DDR & CPU_VTT PWM change to RT8120DGSP	
2011.11.01	H61M-DS2 R2.0 gerber out	
	VBOOT circuit change	
	ISOLAT change from SIO GP40 to SIO GP17	
2011.11.24	H61M-DS2 R2.01 gerber out	

Gigabyte Technology			
BOM & PCB MODIFY HISTORY			
Title	Document Number		Rev
Size	GA-H61M-DS2		2.01
Custom			
Date:	Wednesday, November 30, 2011	Sheet	2 of 30

BLOCK DIAGRAM

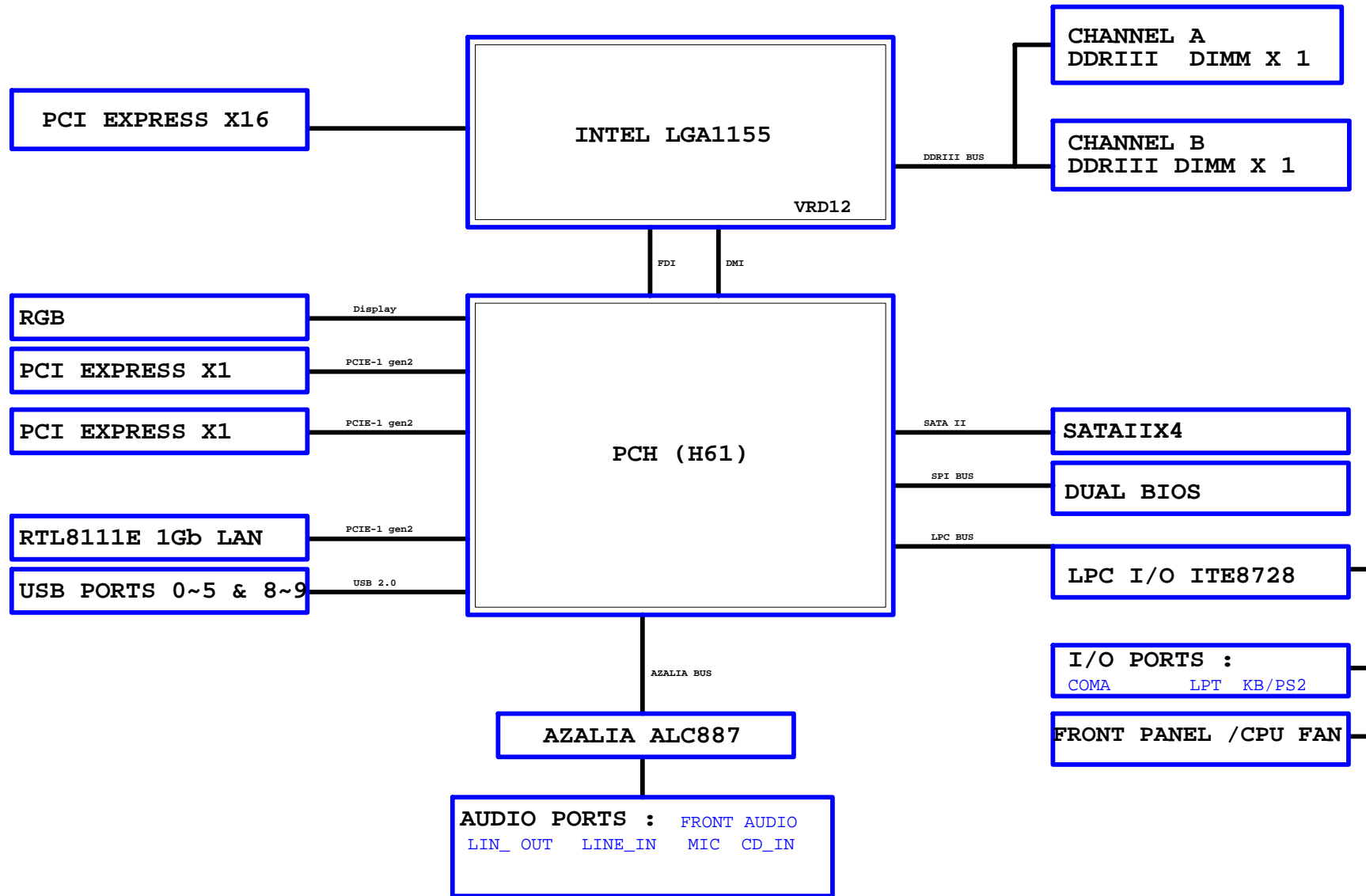

CPUPWROK

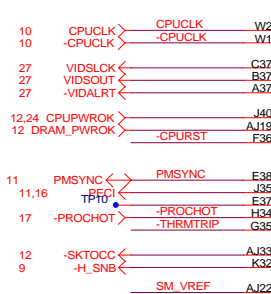

H61M-S2C-B3 remove

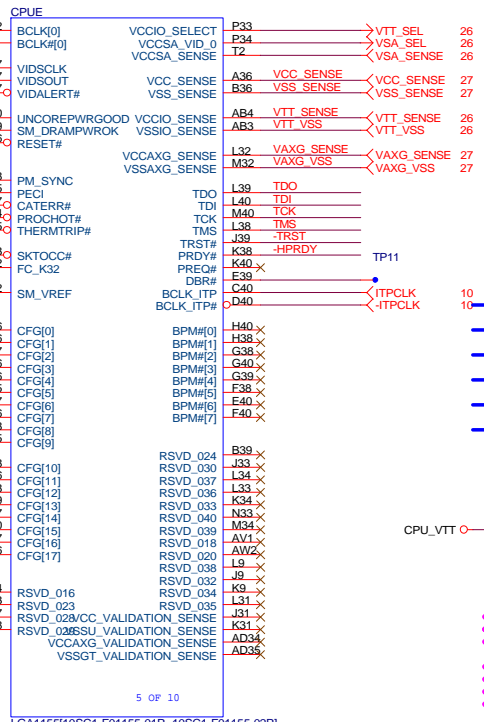

CFG#	H	L	NOTE
0	RSVD	RSVD	RSVD
1	RSVD	RSVD	RSVD
2	NORM	Reverse	LANE REVERSAL[0]..x16
3	RSVD	RSVD	RSVD
4	RSVD	RSVD	RSVD
7	RSVD	RSVD	RSVD
8	RSVD	RSVD	RSVD
9	RSVD	RSVD	RSVD
10	RSVD	RSVD	RSVD
11	RSVD	RSVD	RSVD
12	RSVD	RSVD	RSVD
13	RSVD	RSVD	RSVD
14	RSVD	RSVD	RSVD
15	RSVD	RSVD	RSVD
16	RSVD	RSVD	RSVD
17	RSVD	RSVD	RSVD

CFG6	CFG5	PCIE CONFIG
1	1	1x16, Default
1	0	2x8
0	1	RSVD
0	0	X8, X4, X4

CFG 0-17 all internal PULL-UP

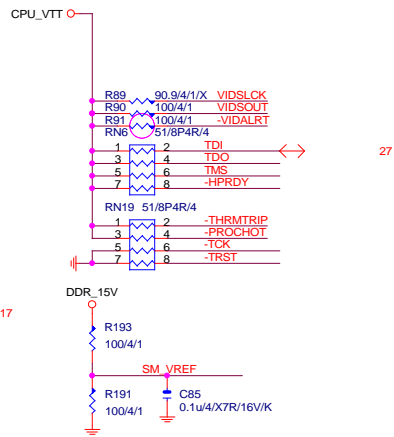
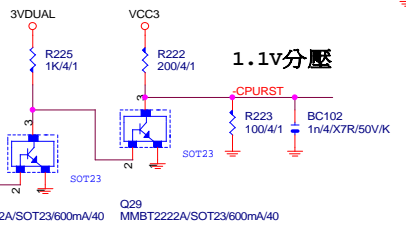
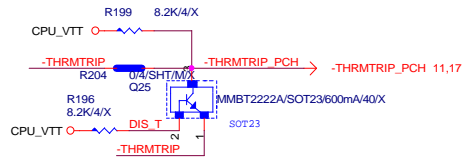
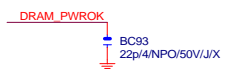

Stitching caps for PCIe,DMI,FDI bus

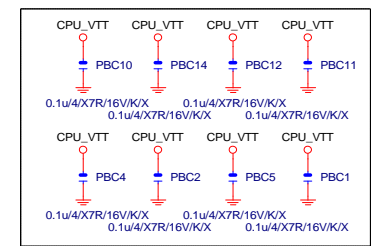
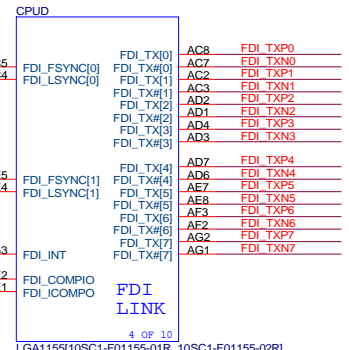
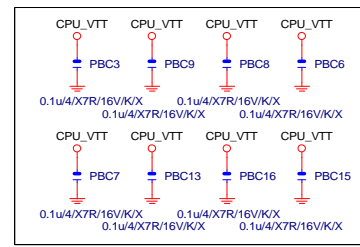

Stitching caps for PCIe,DMI,FDI bus

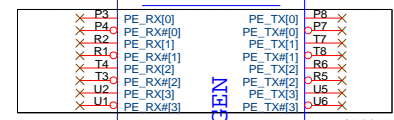
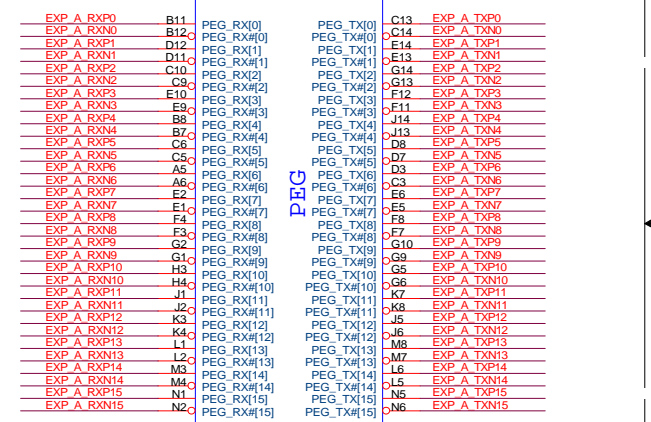

Gigabyte Technology

Title: **GPU LGA1155-A**

Size: **GA-H61M-DS2**

Document Number: **GA-H61M-DS2**

Date: **Wednesday, November 30, 2011**

Sheet: **4** of **30**

Rev: **2.01**

CPUA

MAAA0	AV27	SA_MA[0]	AK3	DQSA0
MAAA1	AV24	SA_MA[1]	AK2	-DQSA0
MAAA2	AW24	SA_MA[2]		
MAAA3	AW23	SA_MA[3]		
MAAA4	AV23	SA_MA[4]	AJ3	MDA0
MAAA5	AT24	SA_MA[5]	AJ4	MDA1
MAAA6	AT23	SA_MA[6]	AI3	MDA2
MAAA7	AU22	SA_MA[7]	AI4	MDA3
MAAA8	AV22	SA_MA[8]	AJ2	MDA4
MAAA9	AT22	SA_MA[9]	AI1	MDA5
MAAA10	AU28	SA_MA[10]	AI2	MDA6
MAAA11	AU21	SA_MA[11]	AI1	MDA7
MAAA12	AT21	SA_MA[12]		
MAAA13	AW32	SA_MA[13]	AP3	DQSA1
MAAA14	AU20	SA_MA[14]	AP2	-DQSA1
MAAA15	AT20	SA_MA[15]		
-SWEA	AW29	SA_WE#	AN1	MDA8
-SCASA	AV30	SA_CAS#	AN4	MDA9
-SRASA	AU28	SA_RAS#	AR3	MDA10
SBA40	SBA40	SA_BS[0]	AR4	MDA12
SBA41	SBA41	SA_BS[1]	AN2	MDA11
SBA42	SBA42	SA_BS[2]	AN3	MDA13
-CSA0	AU29	SA_CS#	AR2	MDA14
-CSA1	AV32	SA_CS#	AR1	MDA15
CKEA0	CKEA0	SA_CKE[0]	AW4	DQSA2
CKEA1	CKEA1	SA_CKE[1]	AV4	-DQSA2
MODT_A0	AV31	SA_ODT[0]	AV2	MDA16
MODT_A1	AU32	SA_ODT[1]	AW3	MDA17
AU30	AU30	SA_ODT[2]	AV5	MDA18
AU33	AU33	SA_ODT[3]	AW5	MDA19
DCLKA0	DCLKA0	SA_CK[0]	AJ2	MDA20
-DCLKA0	-DCLKA0	SA_CK[0]	AU3	MDA21
DCLKA1	DCLKA1	SA_CK[1]	AU5	MDA22
-DCLKA1	-DCLKA1	SA_CK[1]	AV5	MDA23
DCLKA2	DCLKA2	SA_CK[2]	AW8	DQSA3
-DCLKA2	-DCLKA2	SA_CK[2]	AW8	-DQSA3
DCLKA3	DCLKA3	SA_CK[3]	AW7	MDA24
-DCLKA3	-DCLKA3	SA_CK[3]	AU7	MDA25
DCLKA4	DCLKA4	SA_CK[4]	AW9	MDA26
-DCLKA4	-DCLKA4	SA_CK[4]	AU9	MDA27
DCLKA5	DCLKA5	SA_CK[5]	AW7	MDA28
-DCLKA5	-DCLKA5	SA_CK[5]	AU7	MDA29
DCLKA6	DCLKA6	SA_CK[6]	AW9	MDA30
-DCLKA6	-DCLKA6	SA_CK[6]	AU9	MDA31
DCLKA7	DCLKA7	SA_CK[7]	AV37	DQSA4
-DCLKA7	-DCLKA7	SA_CK[7]	AV36	-DQSA4
AU13	AU13	SA_DQS[8]	AJ35	MDA32
AV12	AV12	SA_DQS[8]	AW37	MDA33
AU12	AU12	SA_DQS[9]	AJ39	MDA34
AU14	AU14	SA_DQS[9]	AJ36	MDA35
AV13	AV13	SA_DQS[9]	AW35	MDA36
AU13	AU13	SA_ECC_CB[0]	AJ36	MDA37
AV11	AV11	SA_ECC_CB[1]	AJ38	MDA38
AV12	AV12	SA_ECC_CB[2]	AJ37	MDA39
AV13	AV13	SA_ECC_CB[3]	AJ37	MDA39
AV13	AV13	SA_ECC_CB[4]	AP38	DQSA5
AV11	AV11	SA_ECC_CB[5]	AP39	-DQSA5
AV12	AV12	SA_ECC_CB[6]	AR40	MDA40
AV12	AV12	SA_ECC_CB[7]	AR37	MDA41
			AN38	MDA42
			AN37	MDA43
			AR39	MDA44
			AR38	MDA45
			AN39	MDA46
			AN40	MDA47
			AK38	DQSA6
			AK39	-DQSA6
			AL40	MDA48
			AL37	MDA49
			AJ38	MDA50
			AJ37	MDA51
			AL39	MDA52
			AL38	MDA53
			AJ39	MDA54
			AJ40	MDA55
			AF38	DQSA7
			AF39	-DQSA7
			AG40	MDA56
			AG37	MDA57
			AE39	MDA58
			AE37	MDA59
			AG39	MDA60
			AG38	MDA61
			AE39	MDA62
			AE40	MDA63

DDR_0

1 OF 10

LGA1155[10SC1-F01155-01R_10SC1-F01155-02R]

CPUB

MAAB0	AK24	SB_MA[0]	AH7	DQSB0
MAAB1	AM20	SB_MA[1]	AH6	-DQSB0
MAAB2	AM19	SB_MA[2]		
MAAB3	AK18	SB_MA[3]		
MAAB4	AP19	SB_MA[4]	AG7	MDB0
MAAB5	AP18	SB_MA[5]	AG8	MDB1
MAAB6	AM18	SB_MA[6]	AJ9	MDB2
MAAB7	AI18	SB_MA[7]	AJ8	MDB3
MAAB8	AN18	SB_MA[8]	AG5	MDB4
MAAB9	AV17	SB_MA[9]	AG6	MDB5
MAAB10	AI16	SB_MA[10]	AJ6	MDB6
MAAB11	AU17	SB_MA[11]	AJ7	MDB7
MAAB12	AT18	SB_MA[12]		
MAAB13	AR28	SB_MA[13]	AM8	DQSB1
MAAB14	AI16	SB_MA[14]	AL8	-DQSB1
MAAB15	AV16	SB_MA[15]		
-SWEB	-SWEB	SB_WE#	AL7	MDB8
-SCASB	-SCASB	SB_CAS#	AM7	MDB9
-SRASB	-SRASB	SB_RAS#	AM10	MDB10
SBAB0	AP23	SB_BS[0]	AL10	MDB11
SBAB1	SBAB1	SB_BS[1]	AL6	MDB12
SBAB2	SBAB2	SB_BS[2]	AM6	MDB13
-CSB0	-CSB0	SB_CS#	AL9	MDB14
-CSB1	-CSB1	SB_CS#	AM9	MDB15
CKEB0	CKEB0	SB_CKE[0]	AR8	DQSB2
CKEB1	CKEB1	SB_CKE[1]	AP8	-DQSB2
MODT_B0	AL26	SB_ODT[0]	AP7	MDB16
MODT_B1	AP26	SB_ODT[1]	AR7	MDB17
	AV15	SB_ODT[2]	AP10	MDB18
	AK26	SB_ODT[3]	AR10	MDB19
			AP6	MDB20
			AR6	MDB21
			AP9	MDB22
			AR9	MDB23
			AM13	DQSB3
			AM12	-DQSB3
DCLKB0	DCLKB0	SB_CK[0]	AM12	MDB24
-DCLKB0	-DCLKB0	SB_CK[0]	AM13	MDB25
DCLKB1	DCLKB1	SB_CK[1]	AR13	MDB26
-DCLKB1	-DCLKB1	SB_CK[1]	AP13	MDB27
			AL12	MDB28
			AR13	MDB29
			AR12	MDB30
			AP12	MDB31
			AN29	DQSB4
			AN28	-DQSB4
VREF_DOB	AH1	FC_AH1	AR28	MDB32
VREF_DOA	AH4	FC_AH4	AR29	MDB33
			AL28	MDB34
			AL29	MDB35
			AP28	MDB36
			AP29	MDB37
			AM28	MDB38
			AM29	MDB39
			AP33	DQSB5
			AR33	-DQSB5
			AP32	MDB40
			AP31	MDB41
			AP35	MDB42
			AP34	MDB43
			AR32	MDB44
			AR31	MDB45
			AR35	MDB46
			AR34	MDB47
			AL33	DQSB6
			AM33	-DQSB6
			AM32	MDB48
			AM31	MDB49
			AL35	MDB50
			AL32	MDB51
			AM34	MDB52
			AL31	MDB53
			AM35	MDB54
			AL34	MDB55
			AG35	DQSB7
			AG34	-DQSB7
			AH35	MDB56
			AH34	MDB57
			AE34	MDB58
			AE35	MDB59
			AJ35	MDB60
			AJ34	MDB61
			AF33	MDB62
			AF35	MDB63

DDR_1

2 OF 10

LGA1155[10SC1-F01155-01R_10SC1-F01155-02R]

CR CPU RETENTION X

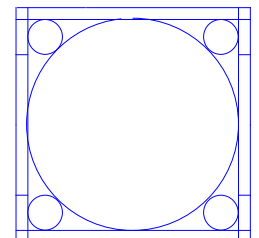

Need check the new CPU ME

CPU



ILM_BP1156/CSP[12KRC-0F0001-04R]

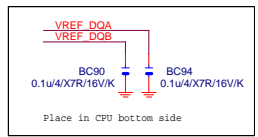

Place in CPU bottom side

Gigabyte Technology

CPU LGA1156-B

Title	CPU LGA1156-B	
Size	Document Number	GA-H61M-DS2
Customer		Rev 2.01
Date:	Wednesday, November 30, 2011	Sheet 5 of 30

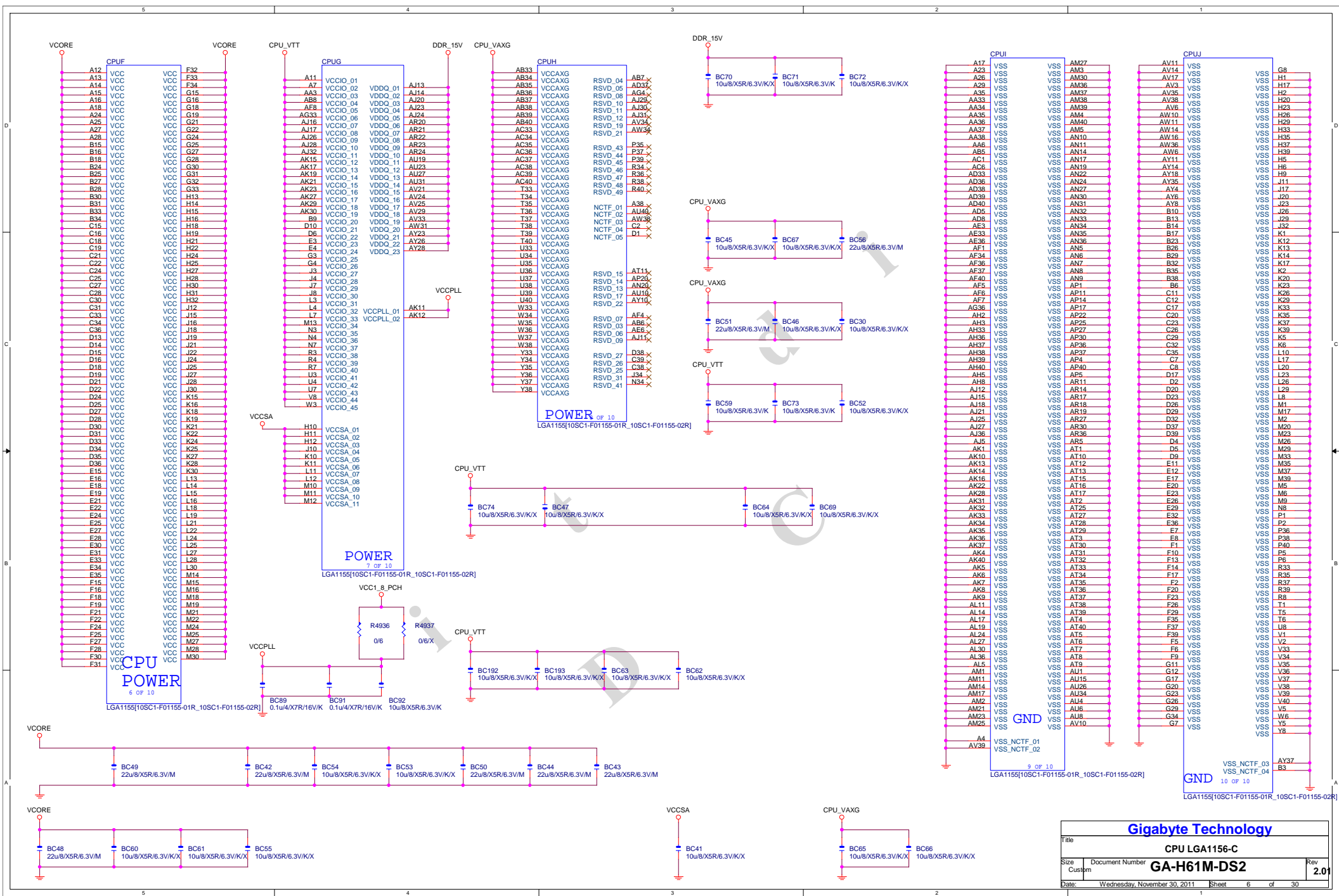

Gigabyte Technology			
CPU LGA1156-C			
Size	Document Number	Rev	
Custom	GA-H61M-DS2	2.01	
Date:	Wednesday, November 30, 2011	Sheet	6 of 30

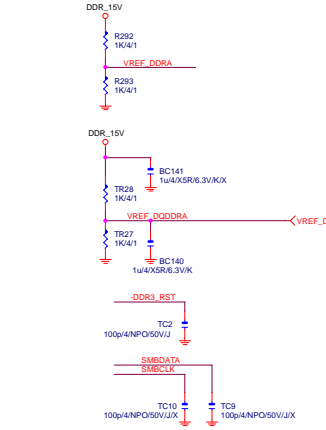
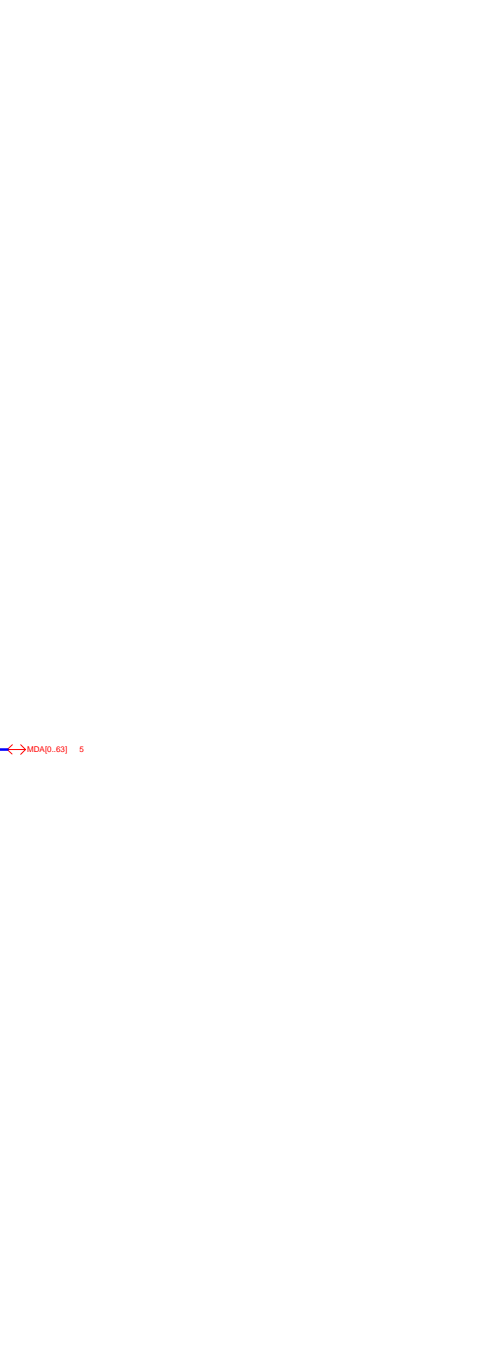
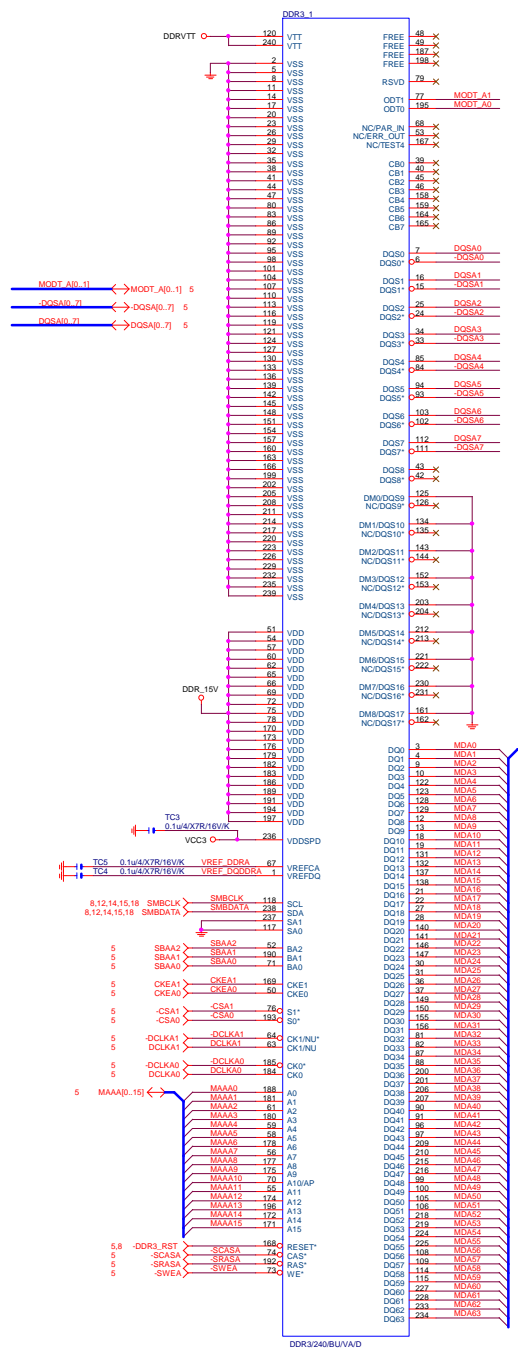

DDR15V Decouple

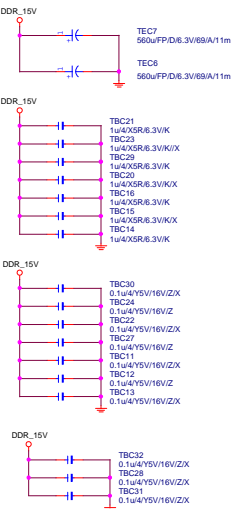

DDRVRTT Decouple

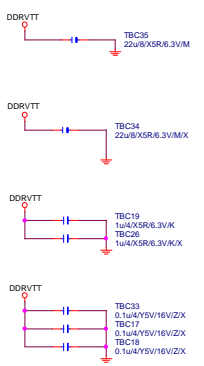

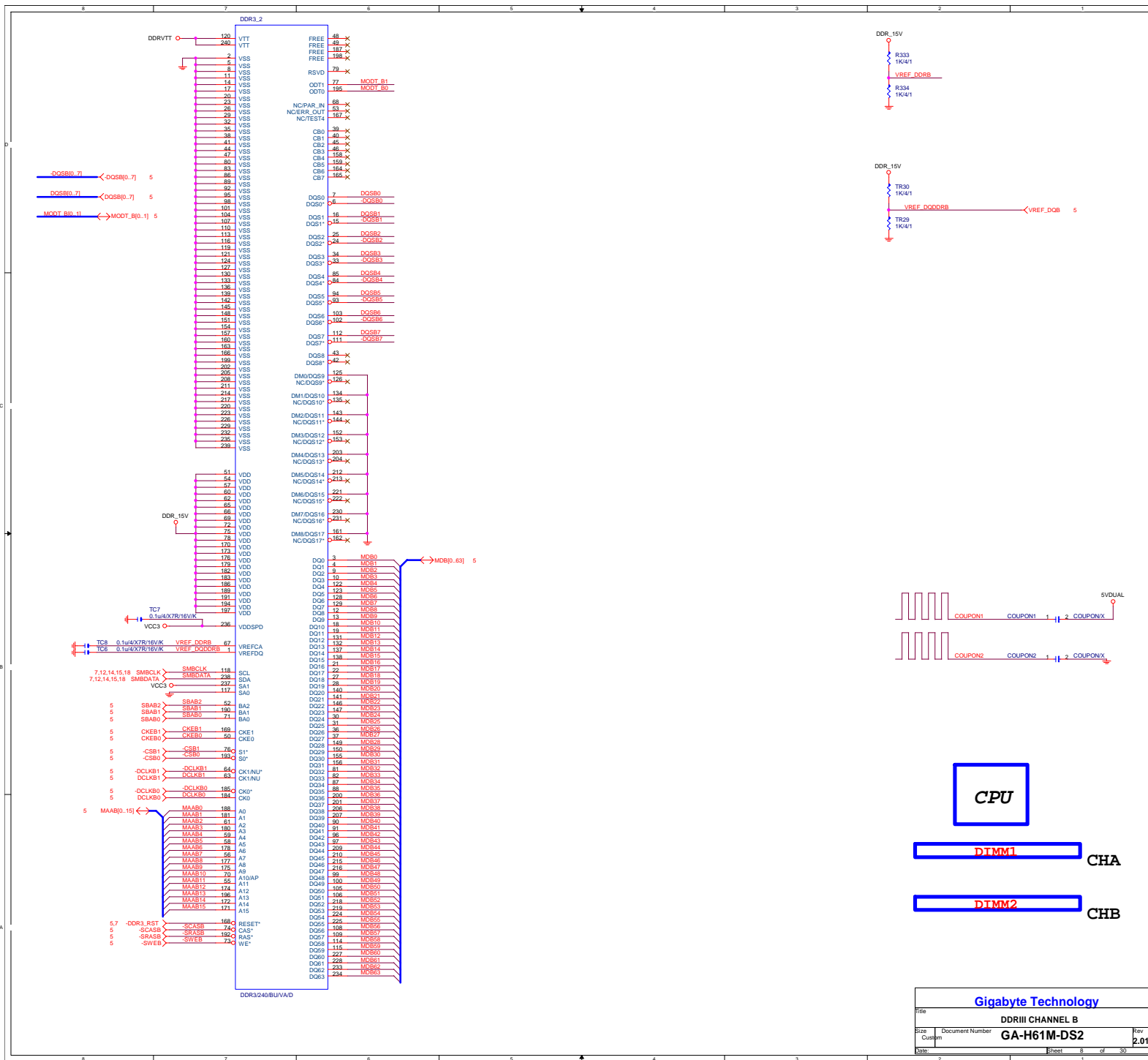

Gigabyte Technology		
Title DDRIII CHANNEL B		
Size	Document Number	Rev
Custpm	GA-H61M-DS2	2.01
Date	Sheet 8 of 30	

H61 disable
USB6,7,12,13

FRONT

REAR

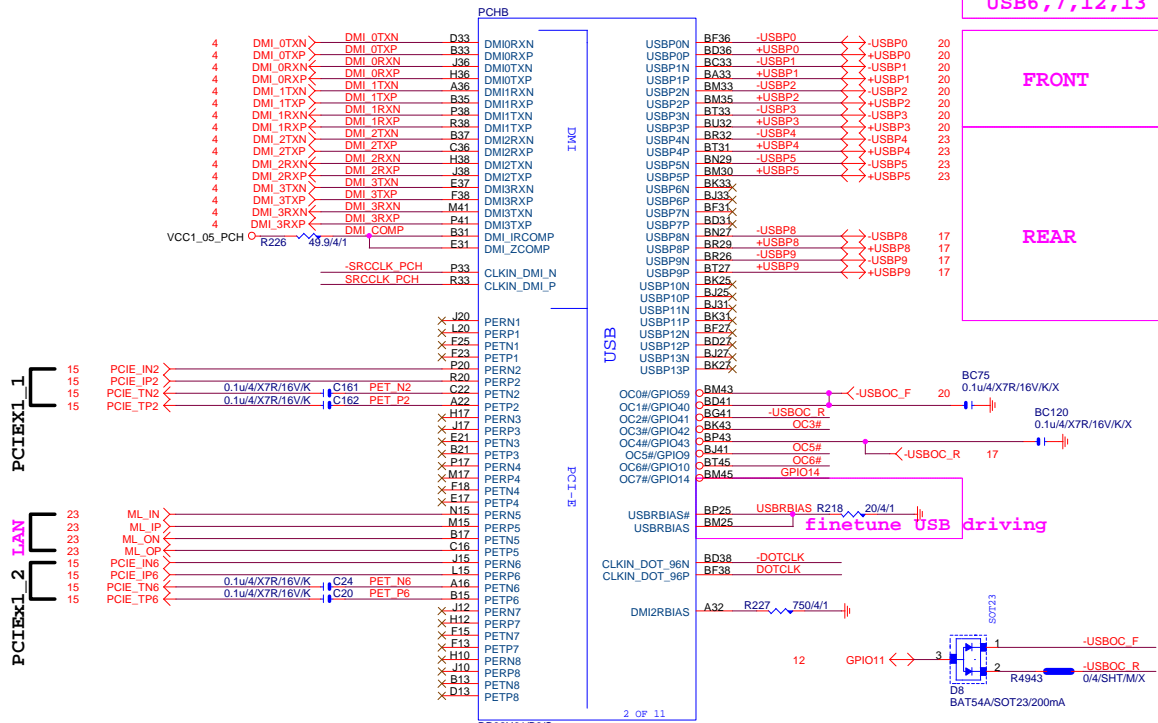
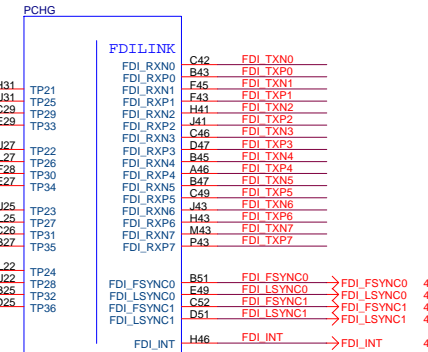

PCIEX1_1

PCIEX1_2 LAN

finetune USB driving

FOR FUSE SHORT GPIO

USB OC#	Configure for H61
OC0#	USB0,1(F_USB1)
OC1#	USB2,3(F_USB2)
OC2#	USB4,5(USB_LAN)
OC3#	N/A
OC4#	USB8,9(R_USB1)
OC5#	USB10-11(R_USB2)
OC6#	N/A
OC7#	GPIO14

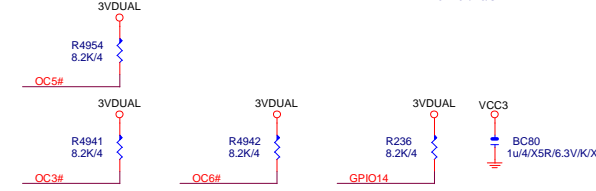

NEW FOOTPRINT: BGAHSINK_PCH_HS

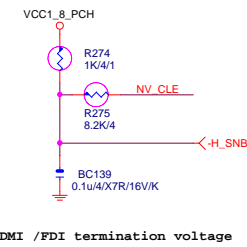
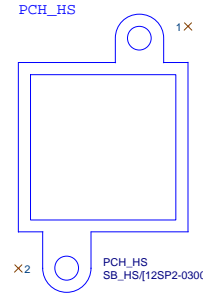

DMI / FDI termination voltage

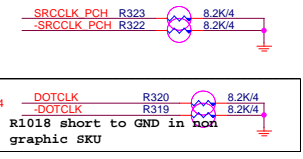

INTERNAL CLK STRAPPING

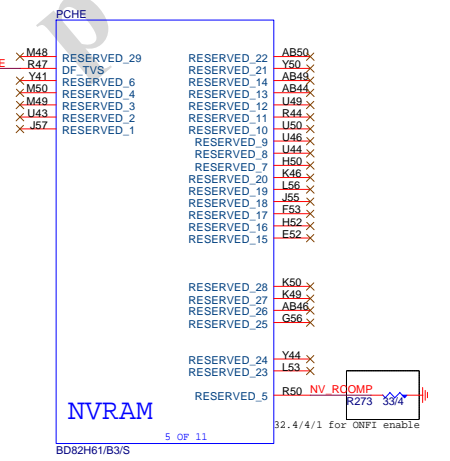

NVRAM

Gigabyte Technology

Title			PCH FDI,DMI,USB ,PCIE,NVRAM		
Size	Document Number	Rev			
Custom	GA-H61M-DS2	2.01			
Date:	Wednesday, November 30, 2011	Sheet	9	of	30

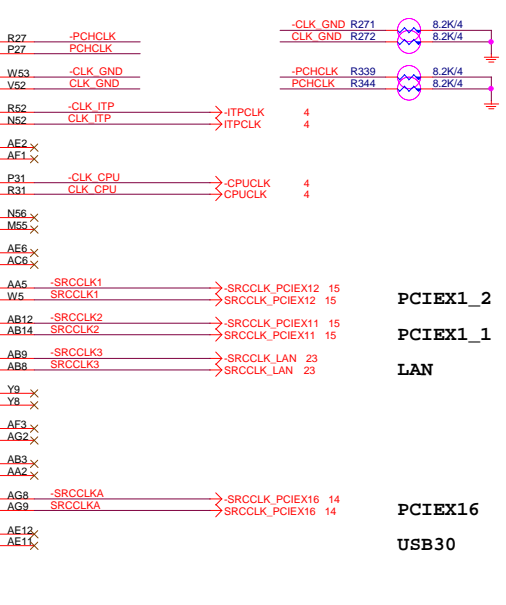
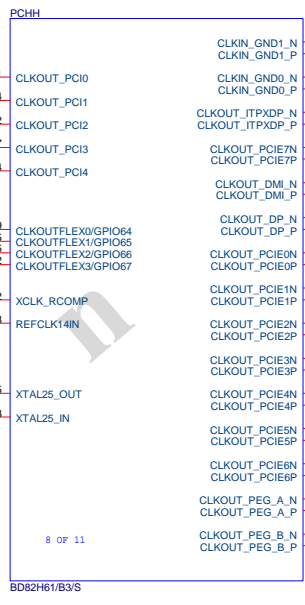
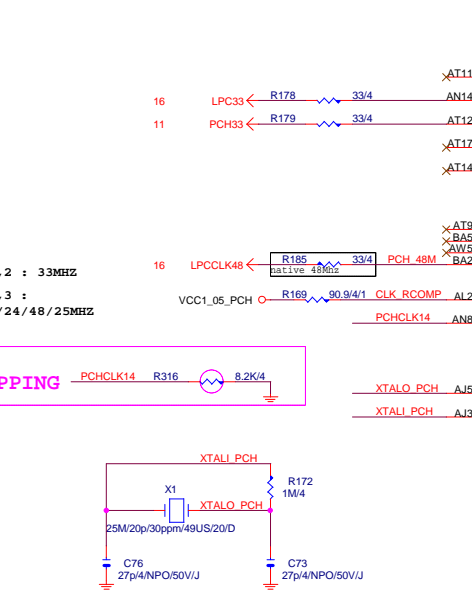
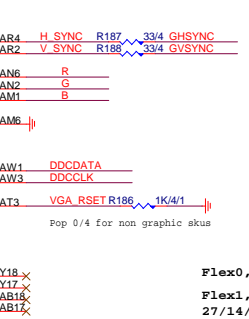
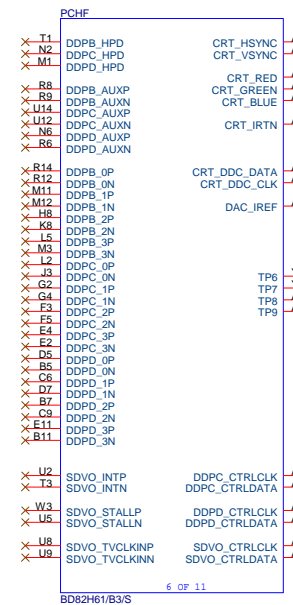

PCIEX1_2
PCIEX1_1
LAN
PCIEX16
USB30

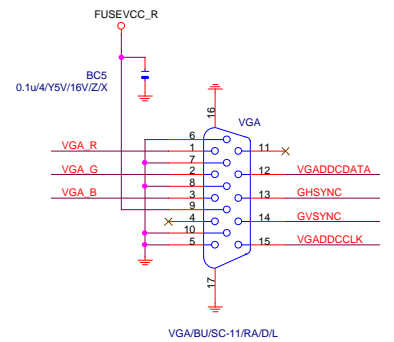
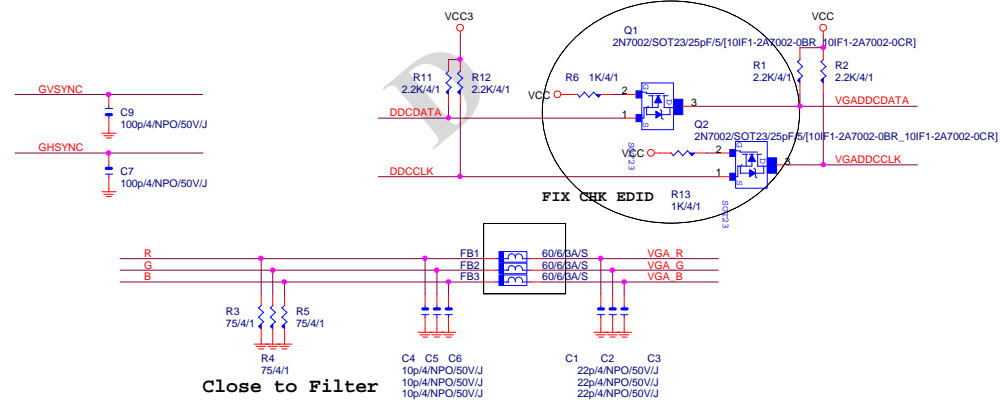
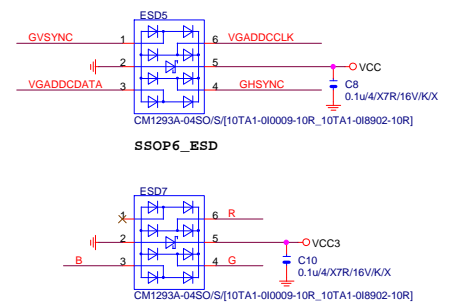

Gigabyte Technology			
PCH DISPLAY, CLK BUFFER			
Title	Document Number	Rev	
Size	Custom	GA-H61M-DS2	
Date:	Wednesday, November 30, 2011	Sheet	10 of 30

H61 SATA3.0 Disable

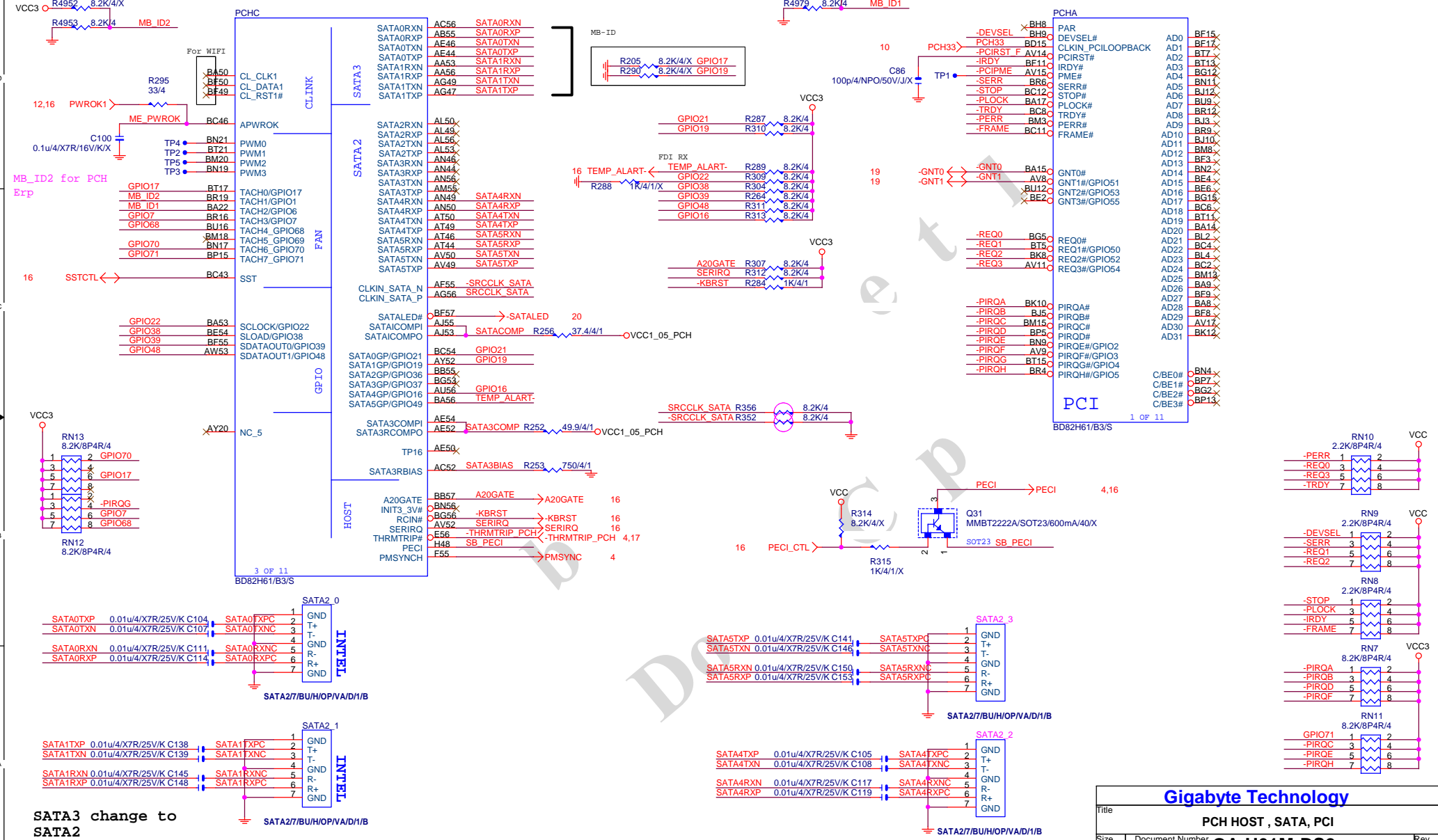

SATA3 change to SATA2

H1X7-SATA2-HS-MASK

Gigabyte Technology

Title: PCH HOST, SATA, PCI		
Size B	Document Number: GA-H61M-DS2	Rev: 2.01
Date:	Wednesday, November 30, 2011	Sheet 11 of 30

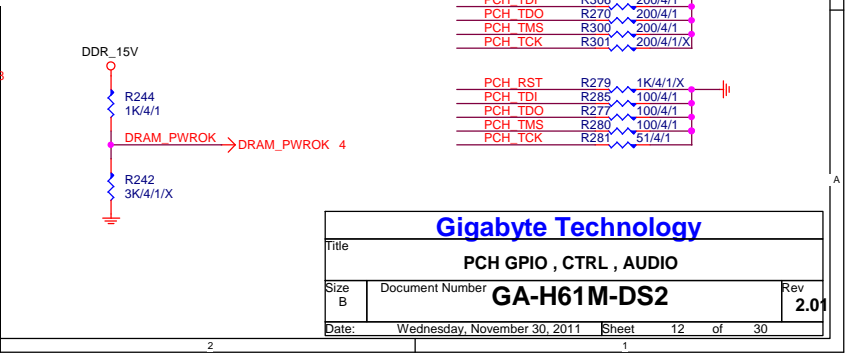
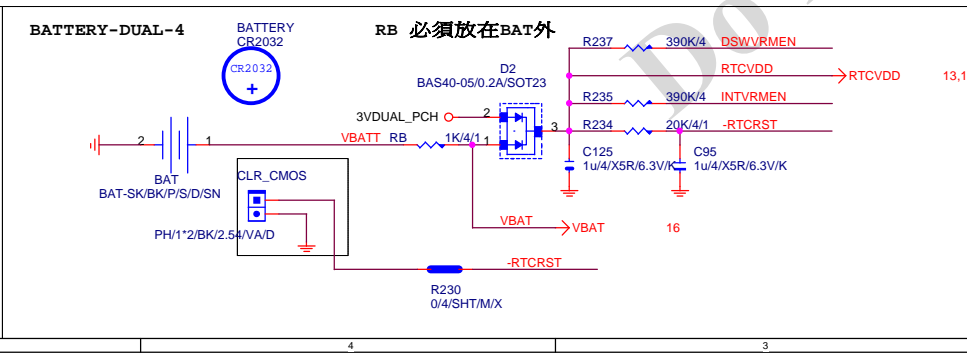
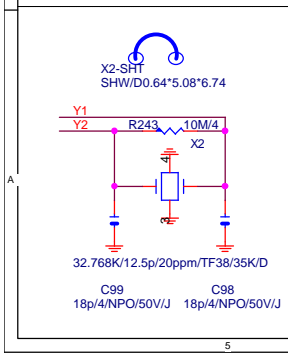
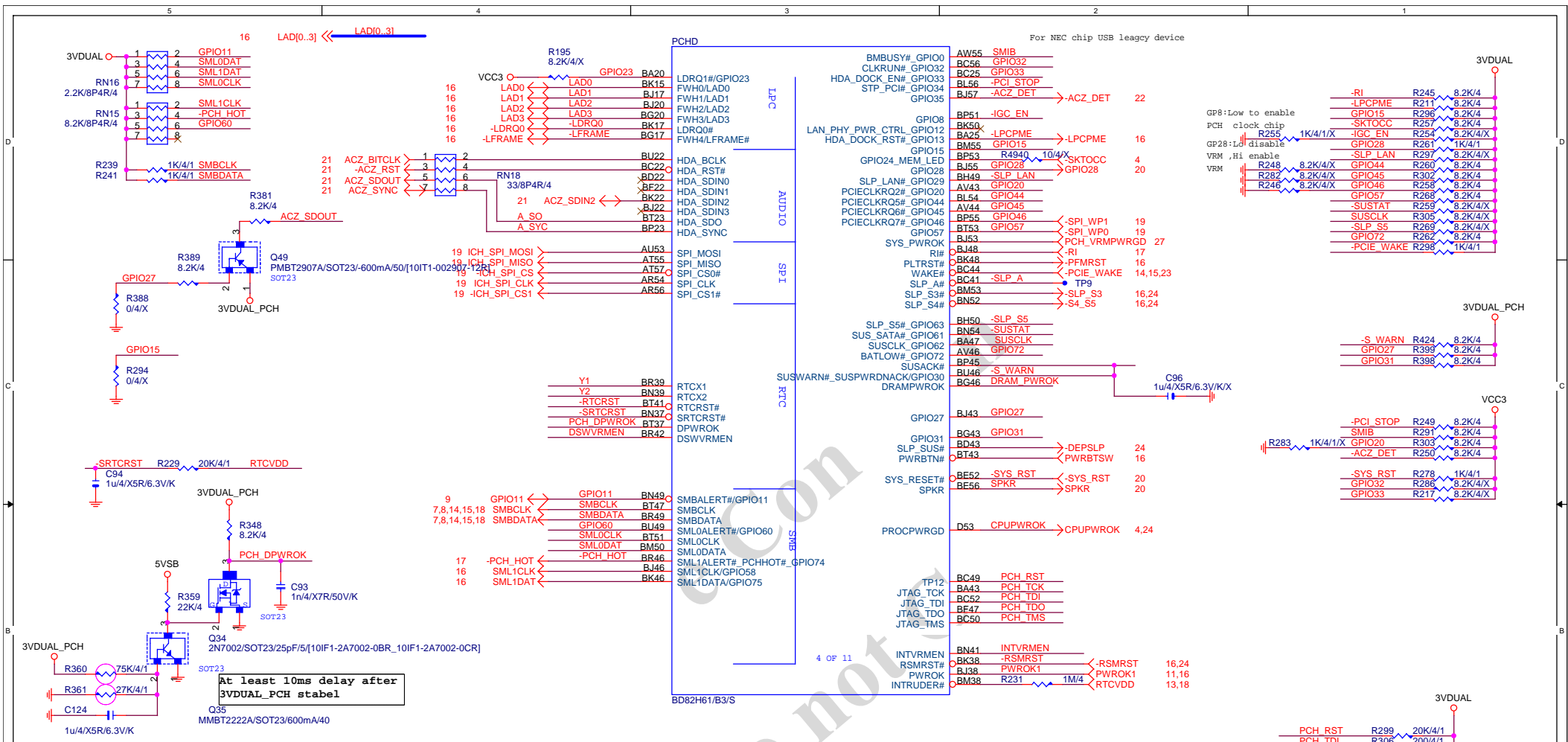

Gigabyte Technology			
PCH GPIO , CTRL , AUDIO			
Size B	Document Number	GA-H61M-DS2	Rev 2.01
Date:	Wednesday, November 30, 2011	Sheet 12	of 30

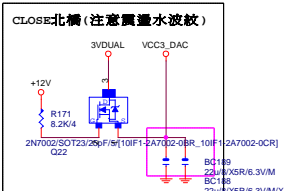
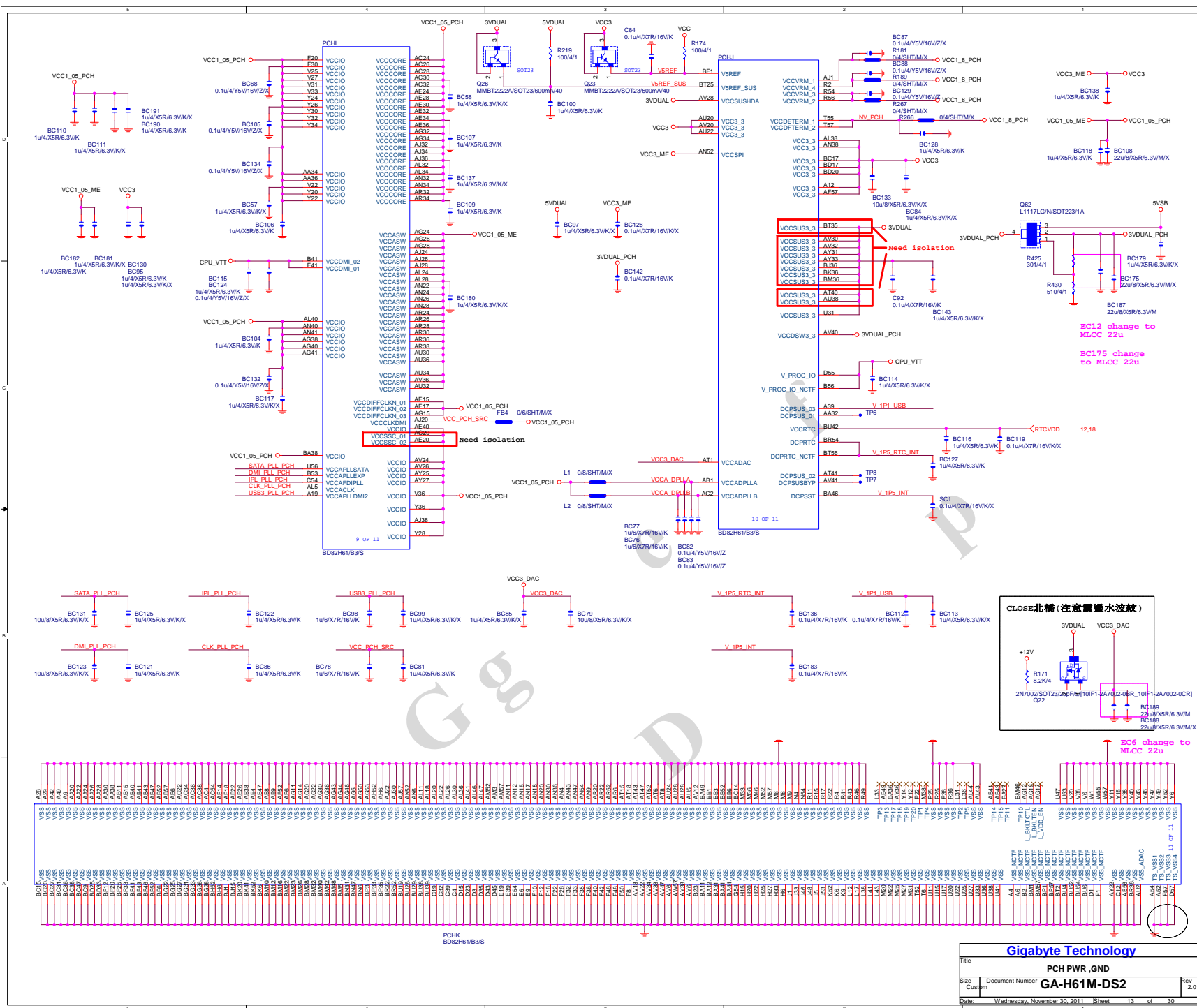

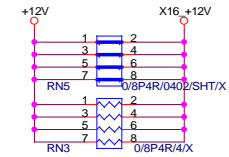
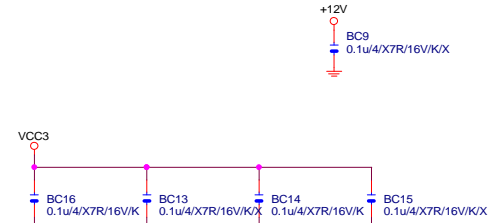

EXP_A_TXP0	C22	0.22u/4X5R/6.3V/K	EXP_A_TXP0C
EXP_A_TXN0	C26	0.22u/4X5R/6.3V/K	EXP_A_TXN0C
EXP_A_TXP1	C29	0.22u/4X5R/6.3V/K	EXP_A_TXP1C
EXP_A_TXN1	C31	0.22u/4X5R/6.3V/K	EXP_A_TXN1C
EXP_A_TXP2	C33	0.22u/4X5R/6.3V/K	EXP_A_TXP2C
EXP_A_TXN2	C35	0.22u/4X5R/6.3V/K	EXP_A_TXN2C
EXP_A_TXP3	C37	0.22u/4X5R/6.3V/K	EXP_A_TXP3C
EXP_A_TXN3	C40	0.22u/4X5R/6.3V/K	EXP_A_TXN3C
EXP_A_TXP4	C48	0.22u/4X5R/6.3V/K	EXP_A_TXP4C
EXP_A_TXN4	C49	0.22u/4X5R/6.3V/K	EXP_A_TXN4C
EXP_A_TXP5	C52	0.22u/4X5R/6.3V/K	EXP_A_TXP5C
EXP_A_TXN5	C54	0.22u/4X5R/6.3V/K	EXP_A_TXN5C
EXP_A_TXP6	C56	0.22u/4X5R/6.3V/K	EXP_A_TXP6C
EXP_A_TXN6	C58	0.22u/4X5R/6.3V/K	EXP_A_TXN6C
EXP_A_TXP7	C60	0.22u/4X5R/6.3V/K	EXP_A_TXP7C
EXP_A_TXN7	C61	0.22u/4X5R/6.3V/K	EXP_A_TXN7C
EXP_A_TXP8	C63	0.22u/4X5R/6.3V/K	EXP_A_TXP8C
EXP_A_TXN8	C64	0.22u/4X5R/6.3V/K	EXP_A_TXN8C
EXP_A_TXP9	C66	0.22u/4X5R/6.3V/K	EXP_A_TXP9C
EXP_A_TXN9	C67	0.22u/4X5R/6.3V/K	EXP_A_TXN9C
EXP_A_TXP10	C69	0.22u/4X5R/6.3V/K	EXP_A_TXP10C
EXP_A_TXN10	C70	0.22u/4X5R/6.3V/K	EXP_A_TXN10C
EXP_A_TXP11	C71	0.22u/4X5R/6.3V/K	EXP_A_TXP11C
EXP_A_TXN11	C72	0.22u/4X5R/6.3V/K	EXP_A_TXN11C
EXP_A_TXP12	C74	0.22u/4X5R/6.3V/K	EXP_A_TXP12C
EXP_A_TXN12	C75	0.22u/4X5R/6.3V/K	EXP_A_TXN12C
EXP_A_TXP13	C77	0.22u/4X5R/6.3V/K	EXP_A_TXP13C
EXP_A_TXN13	C78	0.22u/4X5R/6.3V/K	EXP_A_TXN13C
EXP_A_TXP14	C79	0.22u/4X5R/6.3V/K	EXP_A_TXP14C
EXP_A_TXN14	C80	0.22u/4X5R/6.3V/K	EXP_A_TXN14C
EXP_A_TXP15	C82	0.22u/4X5R/6.3V/K	EXP_A_TXP15C
EXP_A_TXN15	C83	0.22u/4X5R/6.3V/K	EXP_A_TXN15C

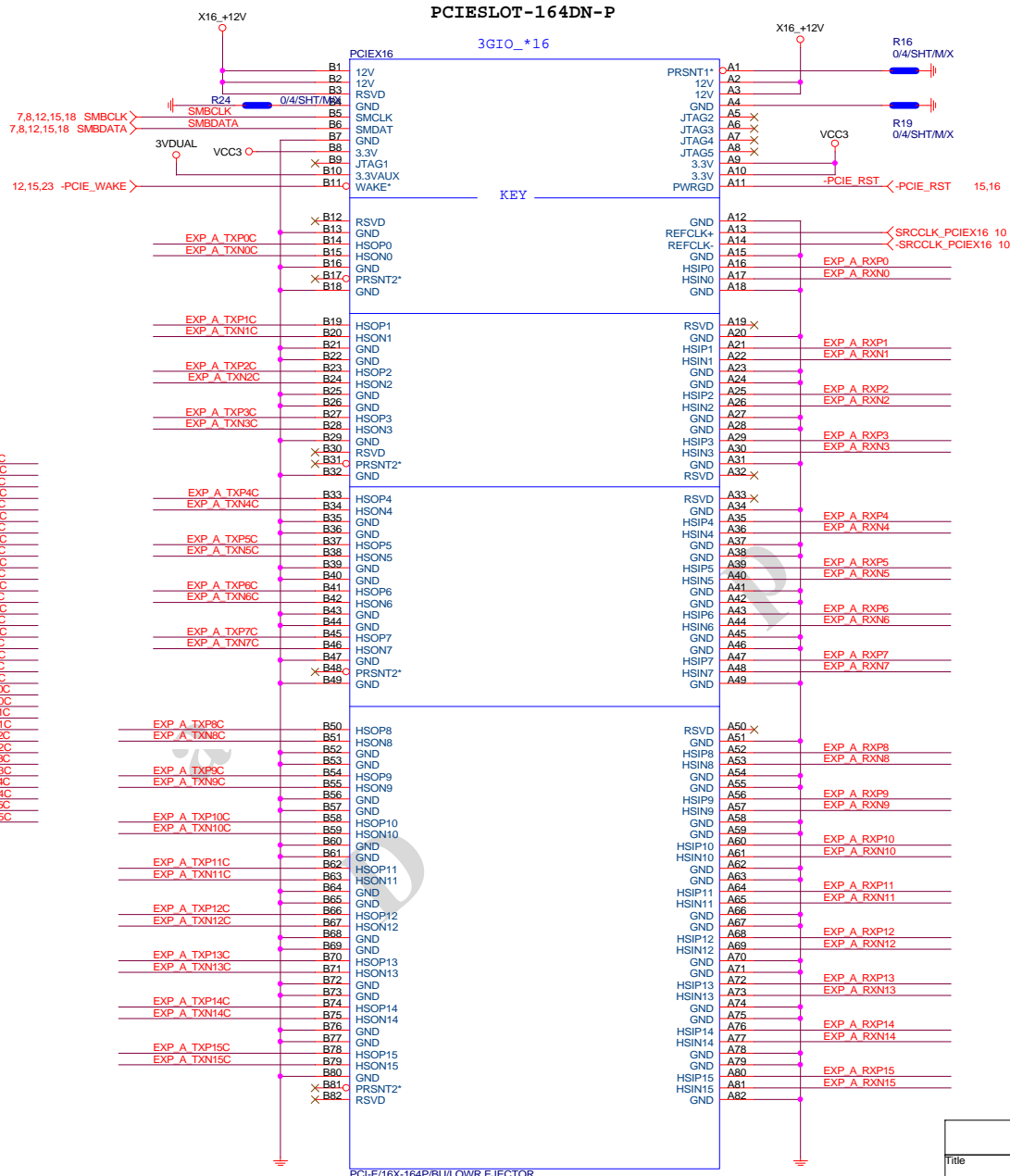

Gigabyte Technology

Title		PCI EXPRESS * 16	
Size	Document Number	GA-H61M-DS2	
Custom		Rev	2.01
Date:	Wednesday, November 30, 2011	Sheet	14 of 30

PCIE*1

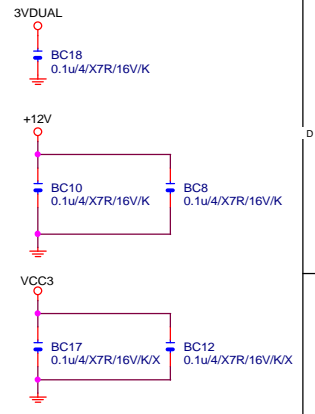
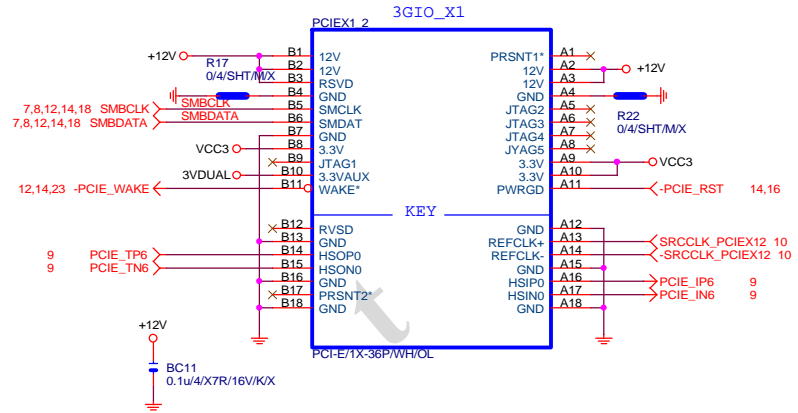
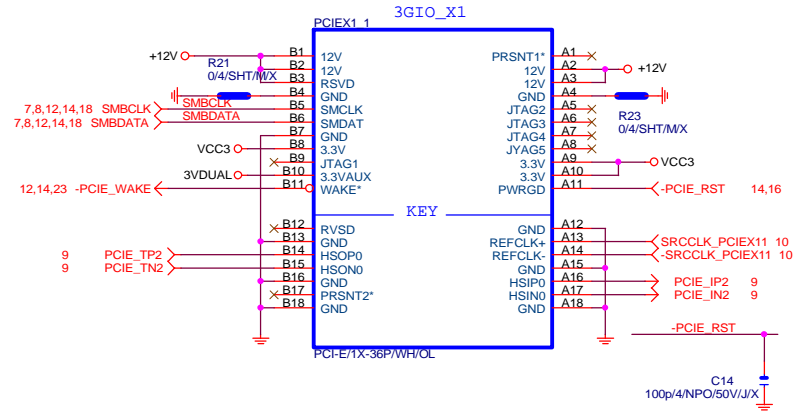

CLK GEN

Gigabyte Technology			
PCIEX1,X2/CLK GEN			
Size Custom	Document Number	GA-H61M-DS2	Rev 2.01
Date:	Wednesday, November 30, 2011	Sheet 15 of 30	

GP22 Default GP22 DIOD8
GP23 Default CPU_PG DOD8

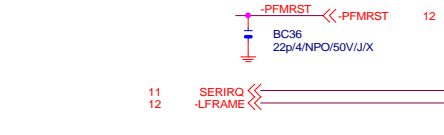
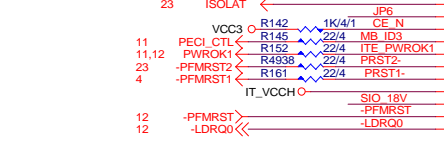
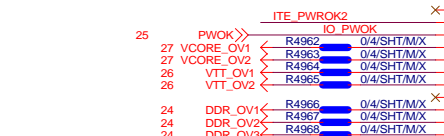
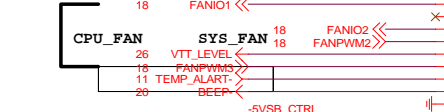
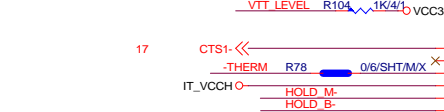
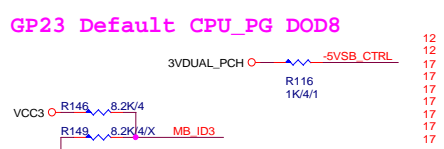

IT8728	
PIN121	VCORE_EN/PCH_C0
PIN120	VLDT_EN/PCH_D0
PIN19	ATXPG
PIN31	PCH_C1
PIN53	SST/AMDTSI_D/MIRB#/PCH_DI
PIN55	PECI/AMDTSI_C/DRV#
PIN66	SYS_3VSB
PIN70	GP47
PIN95	VIN2(VCC5)
PIN96	VIN1(VCC12)
PIN97	VIN1/VDIMM_STR(1.5V)
PIN98	VIN0/VCORE(1.1V)/VNC

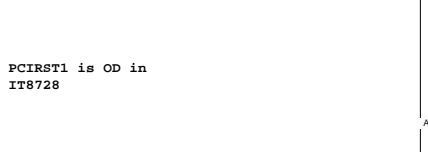
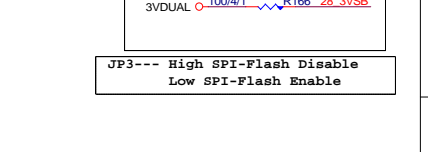
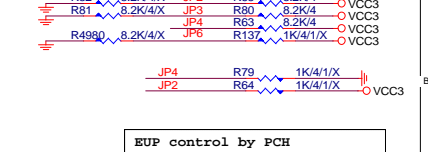
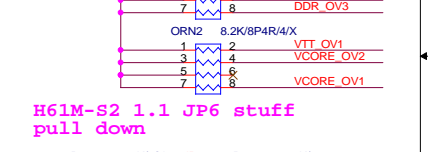
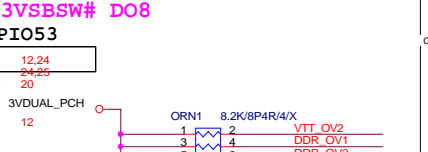
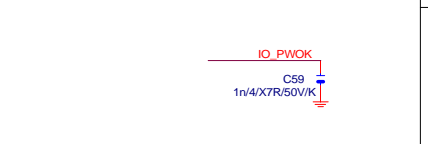
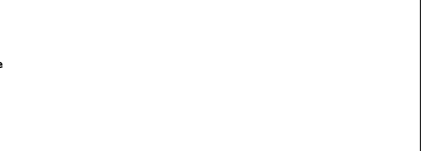
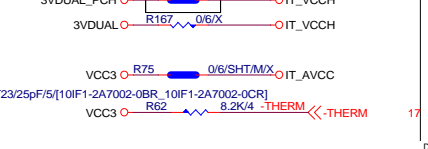
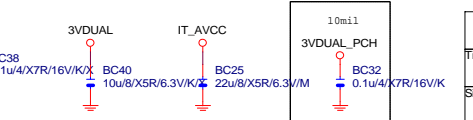
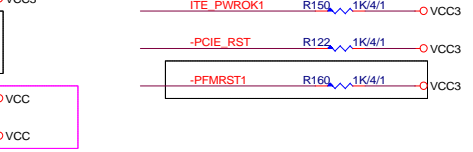
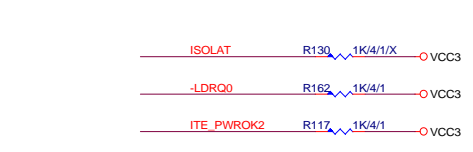
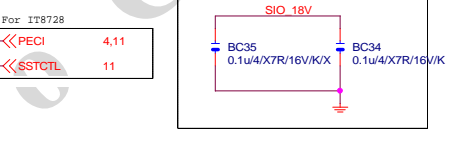
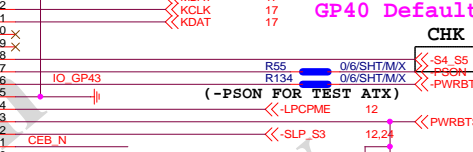
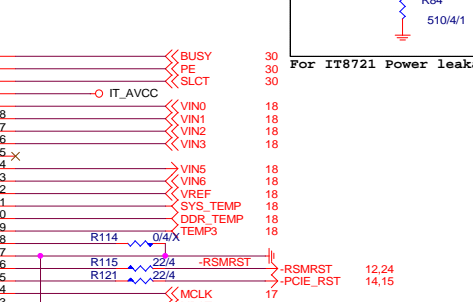
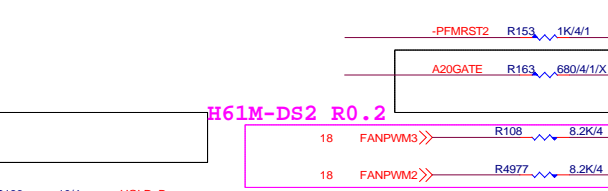
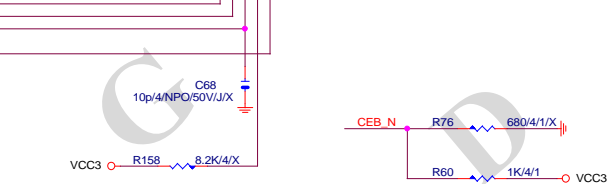
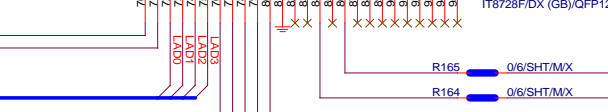
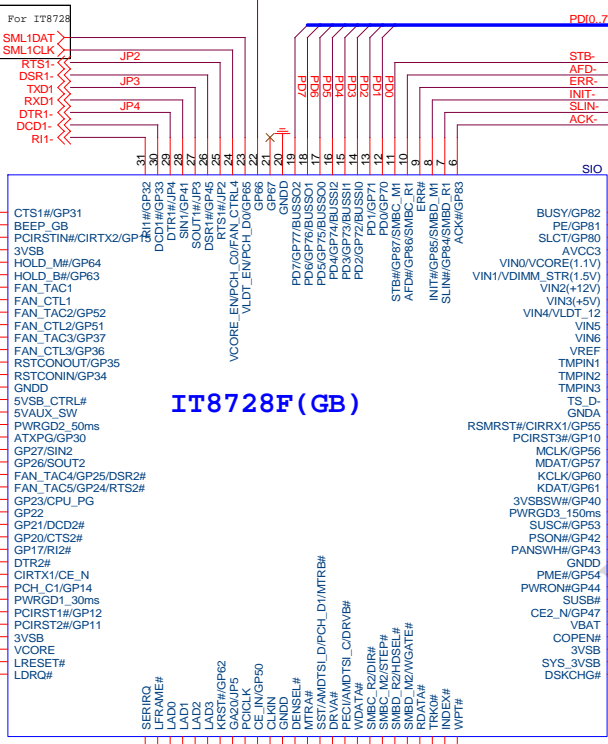

Gigabyte Technology		
Title	ITE 8728 LPC IO	
Size B	Document Number	GA-H61M-DS2
Date:	Wednesday, November 30, 2011	Sheet 16 of 30
	Rev	2.01

internal power pin, max 22nF cap

PCIRST1 is od in
IT8728

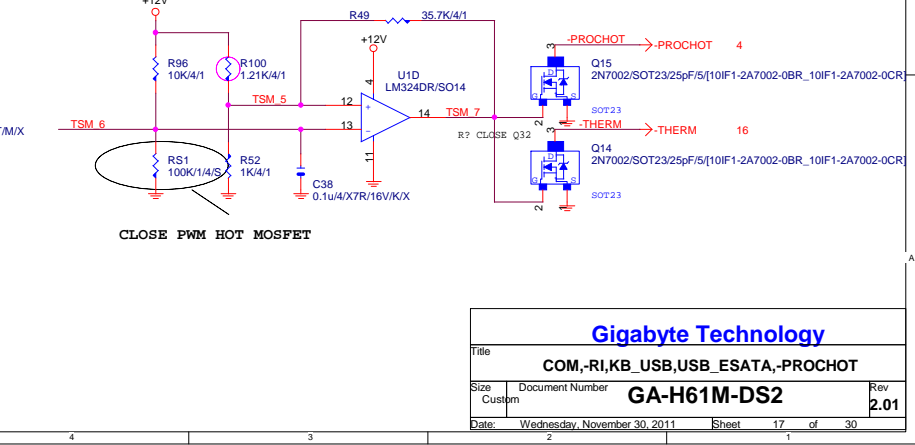
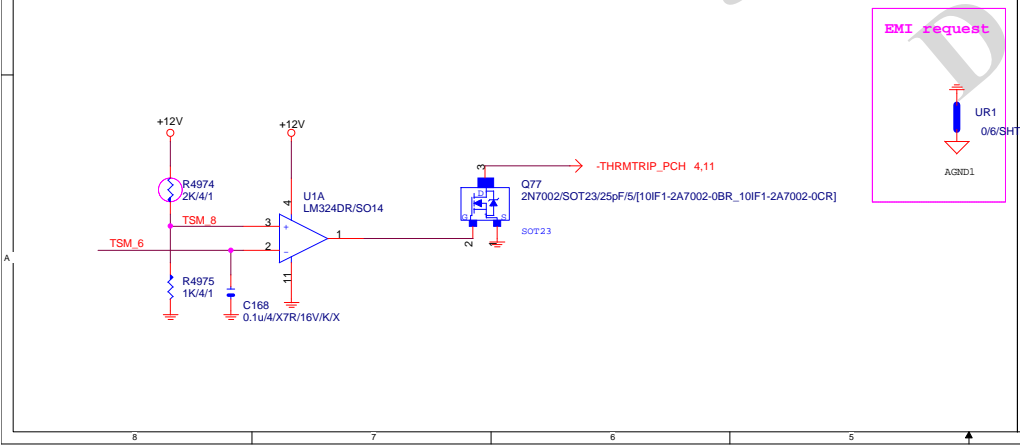
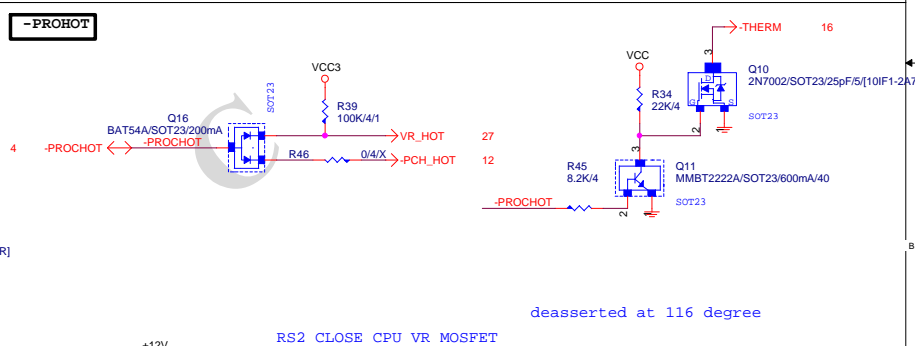
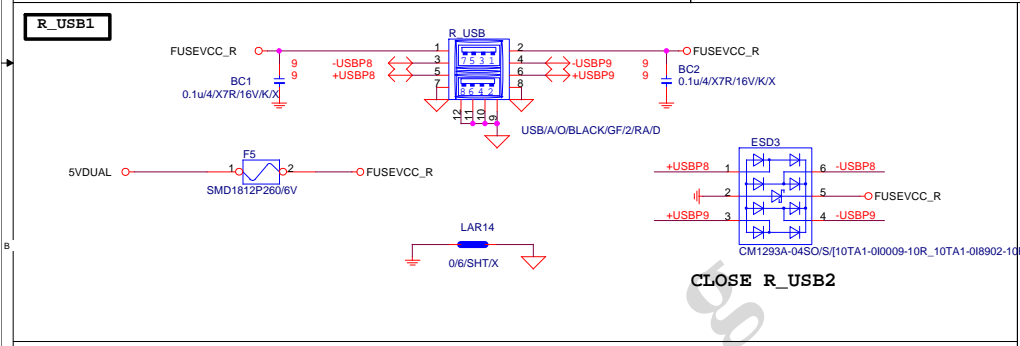
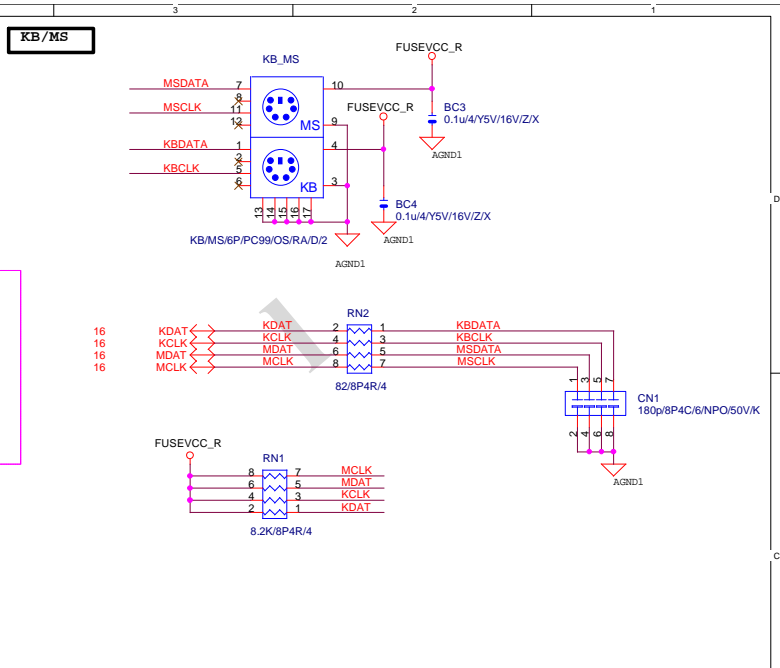
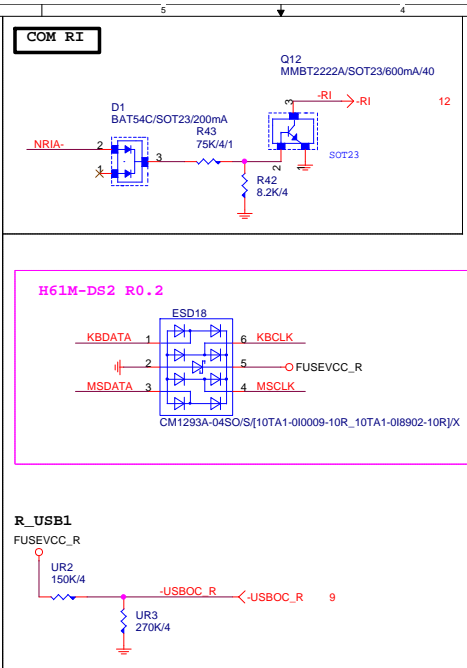
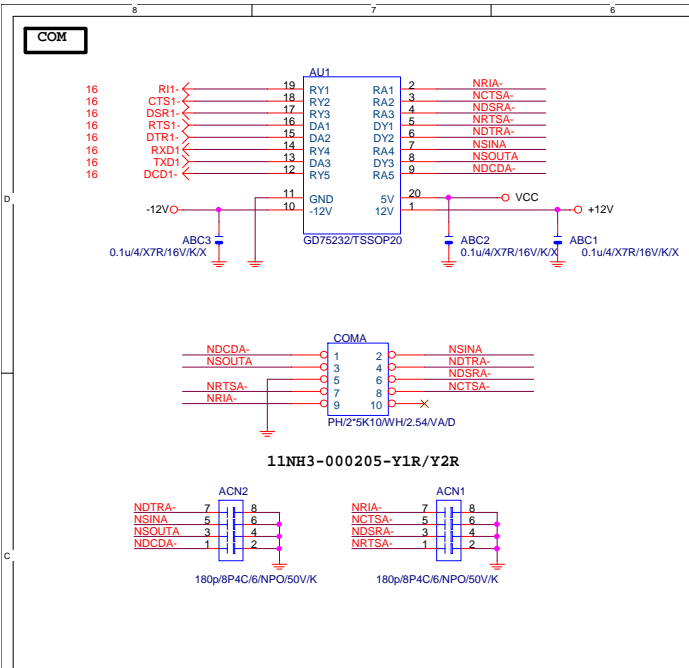

TEMP H/W MONITOR

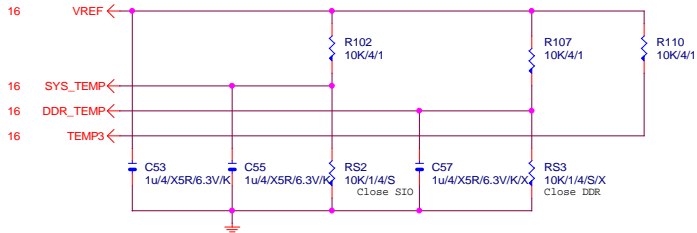

CASE OPEN

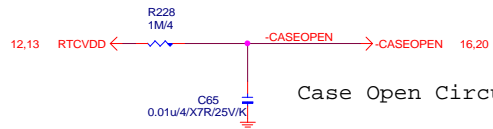

Case Open Circuits

VOLTAGE-- H/W MONITOR

I (VAXG)

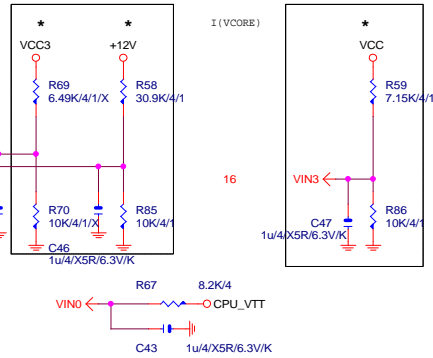

CPU SMART FAN

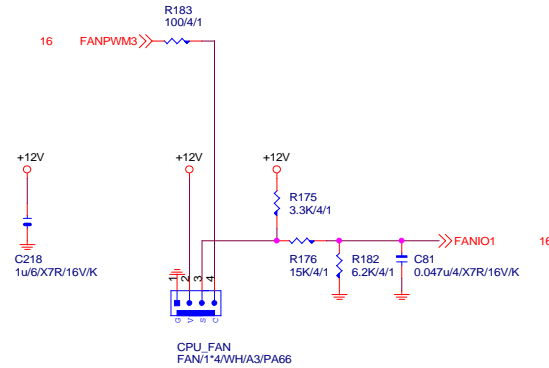

SYS SMART FAN

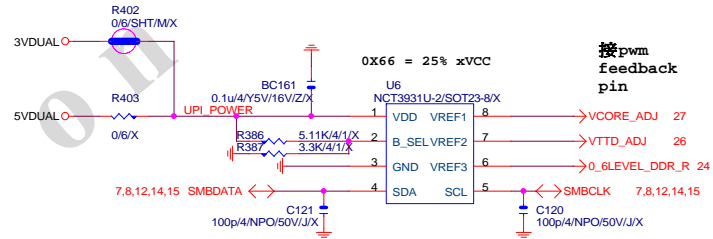
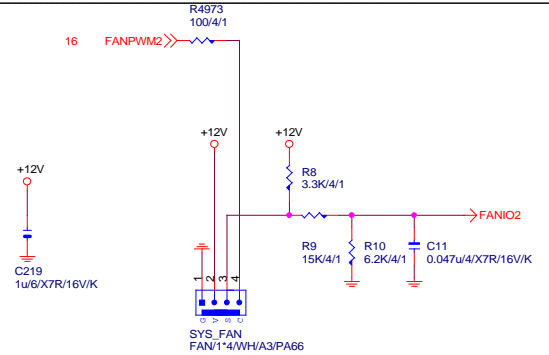

Gigabyte Technology

Title			HWM,FAN CTRL_OV
Size			GA-H61M-DS2
Document Number	Rev	2.01	
Date:	Wednesday, November 30, 2011	Sheet	18 of 30

DUAL BIOS

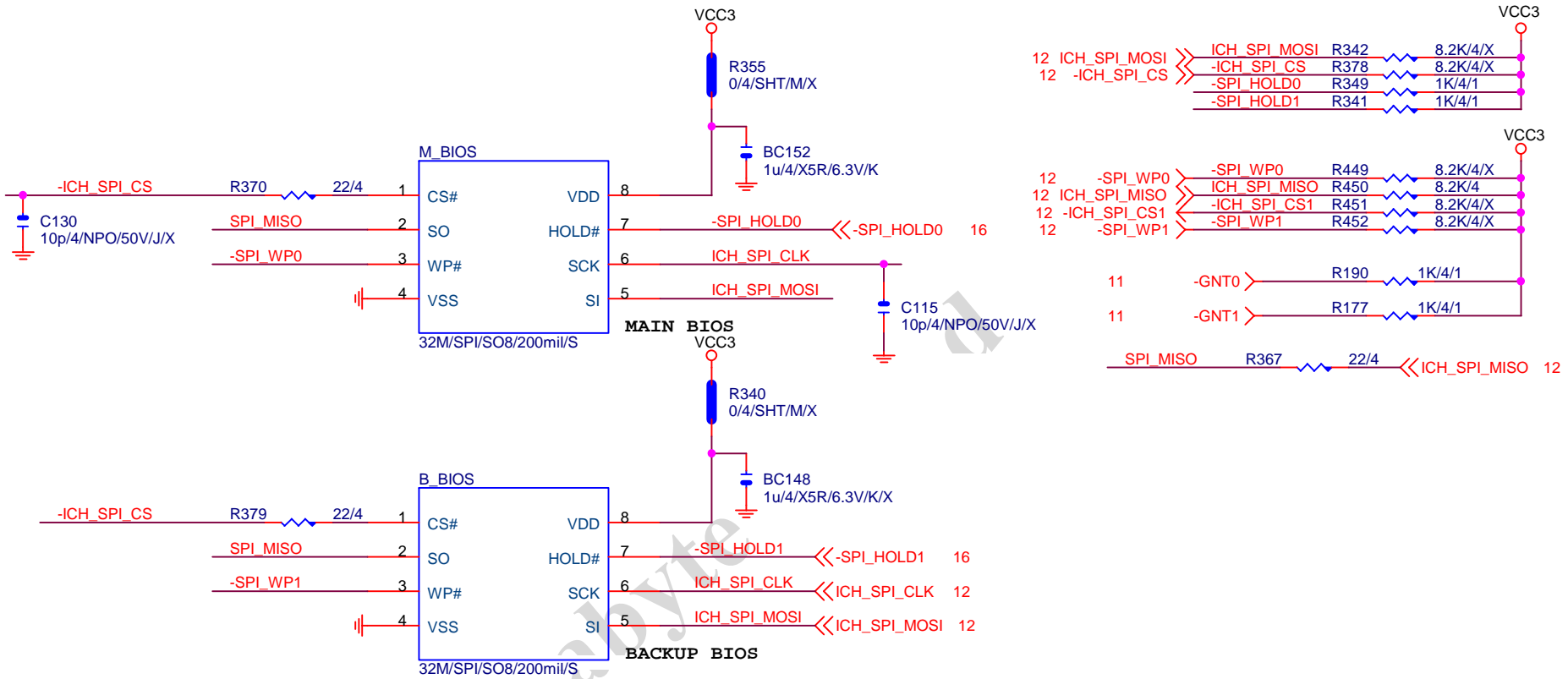

BOOT DEVICE	GNT1	GNT0
LPC	0	0
PCI	0	1
SPI	1	1

1 means floating
0 means PD 1K

Gigabyte Technology

Title		
DUAL BIOS		
Size A	Document Number	Rev
	GA-H61M-DS2	2.01
Date:	Wednesday, November 30, 2011	Sheet 19 of 30

FRONT USB1

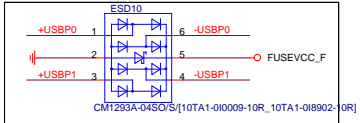
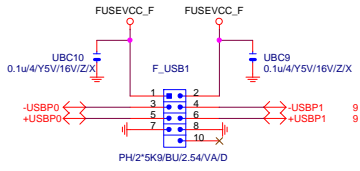

Close to connector

change to BLUE COLOR

SATA LED



CLOSE F_USB1

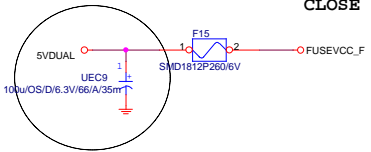

SPKR

RESETCONIN DEFAULT LOW
4sec, 會發BEEP, 故改2N7002

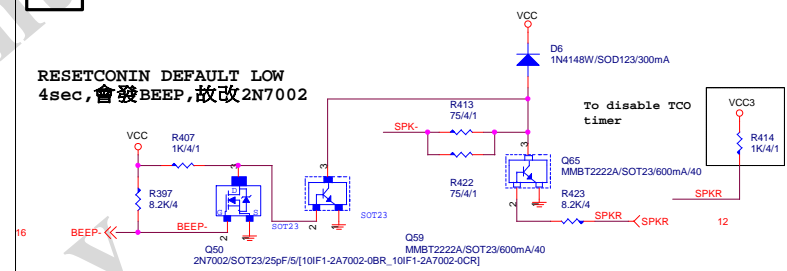

FRONT USB2

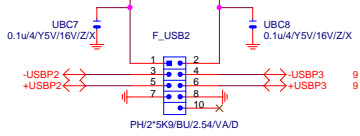

FRONT USB3

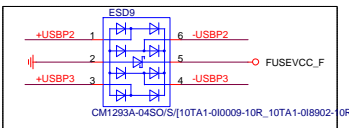

Close to connector

INTEL FRONT PANEL

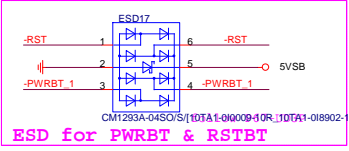

H2X10PANEL-2

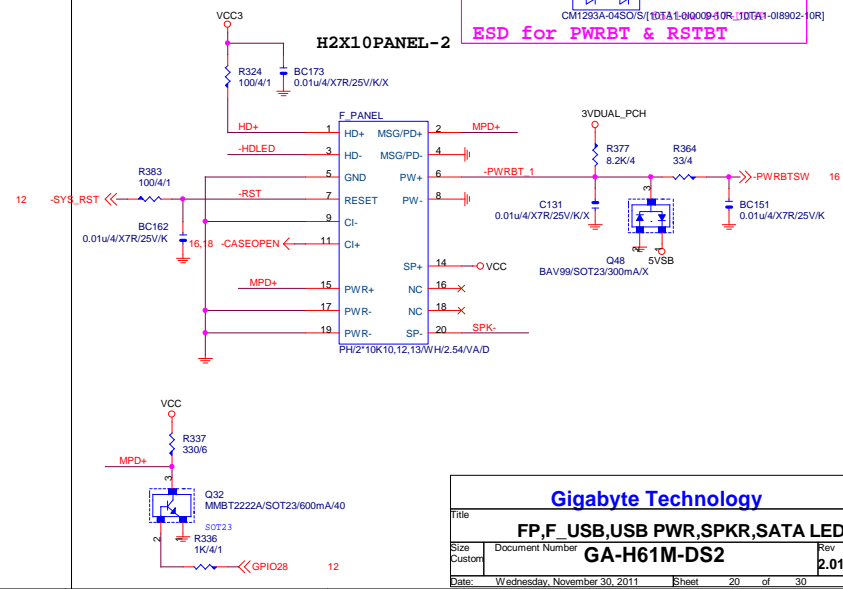

	ALC883	ALC888-VA	ALC888B	ALC888-VD	ALC892R	ALC889	ALC889A
CR46	X	X	X	X	X	X	O
CR57	X	X	X	X	X	X	O
CR49	O	O	X	X	X	O	O
CBC40	X	X	X	10uF/X5R	10uF/X5R	X	X
CR20	O	X	X	X	X	X	X
CR26	20K/1%	20K/1%	20K/1%	20K/1%	20K/1%	20K/1%	20K/0.1%
CR47	X	X	O	X	O	O	X
CR48	O	O	X	O	X	X	O
CBC2/CBC4/CBC5/CBC6/CBC10/CBC11	4.7uF/X5R	4.7uF/X5R	4.7uF/X5R	4.7uF/X5R	4.7uF/X5R	10uF/X5R	4.7uF/X5R
CR1/CR3/CR10/CR12/CR15/CR19/CR56/CR27/CR55/CR37/CR28/CR34/CR6/CR9/CR51/CR61	75 ohm	75 ohm	75 ohm	75 ohm	75 ohm	66 ohm or lower	75 ohm
CR66/CR68/CD3/CBC41	X	X	X	O	X	X	X
CR67/CD1/CD2/CQ3/CQ5	O	O	O	X	O	O	O

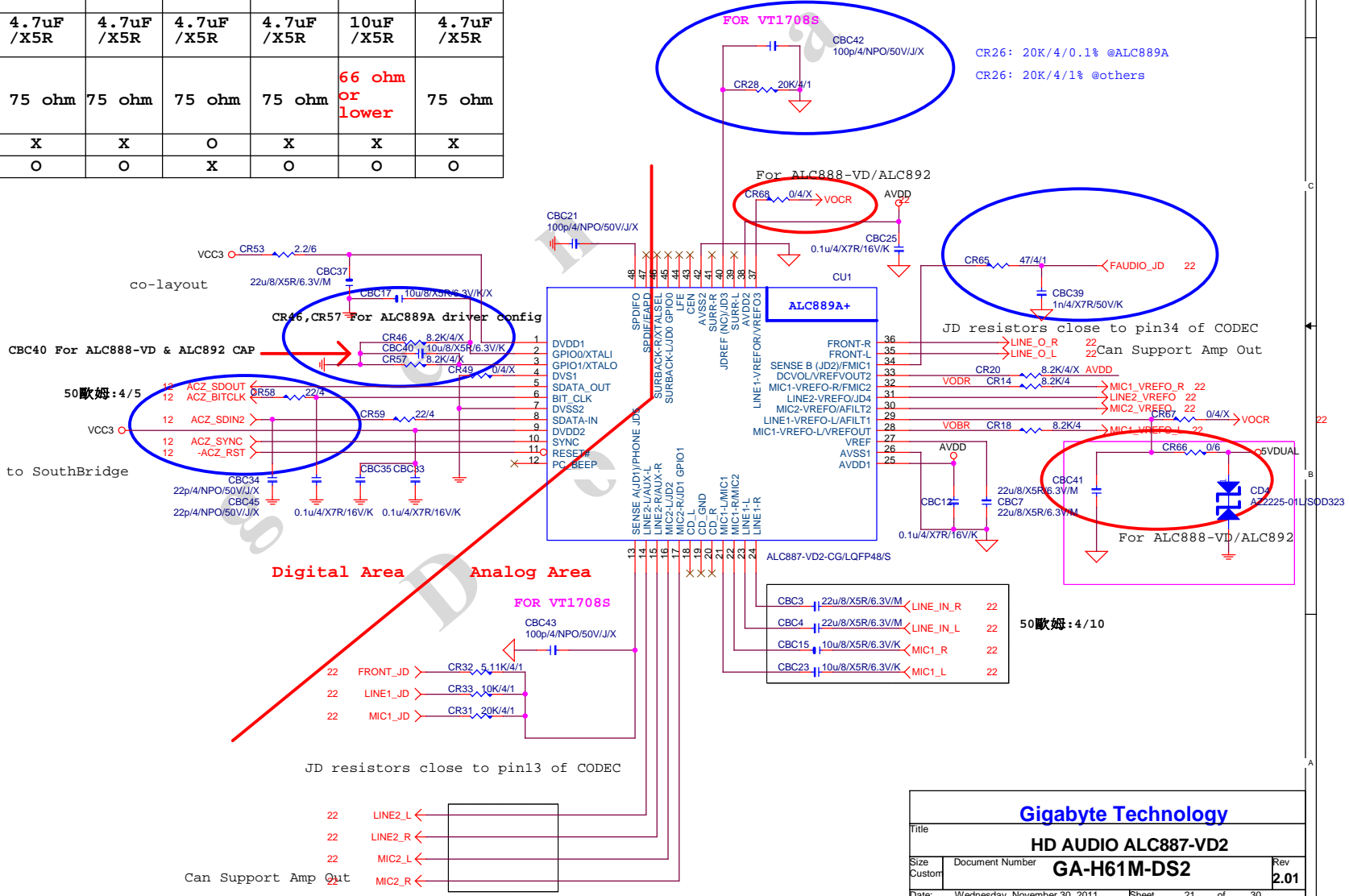

Gigabyte Technology

HD AUDIO ALC887-VD2

Title	HD AUDIO ALC887-VD2		Rev
Size	Document Number	GA-H61M-DS2	2.01
Date:	Wednesday, November 30, 2011	Sheet	21 of 30

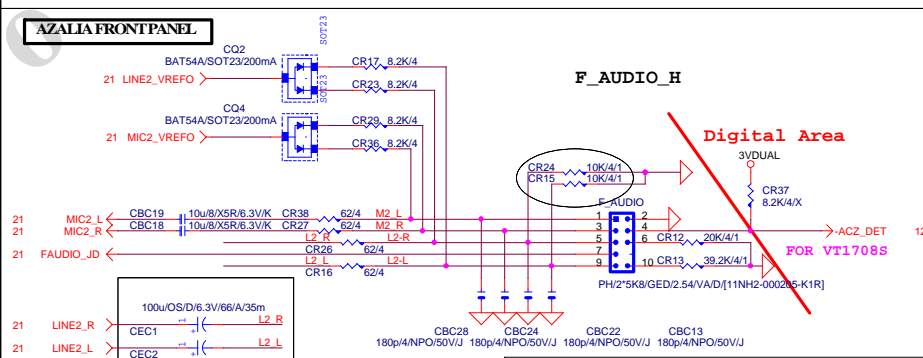
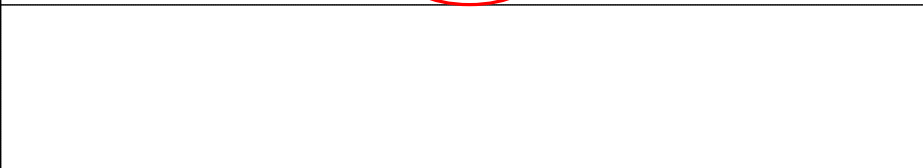
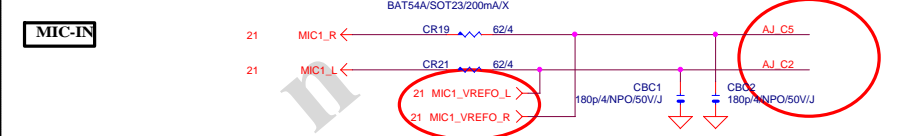
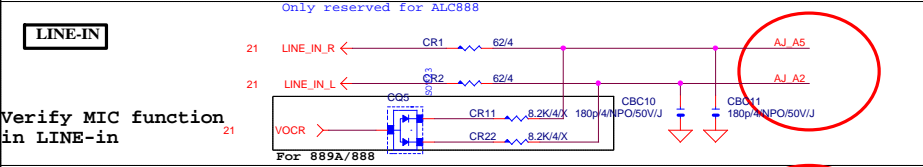
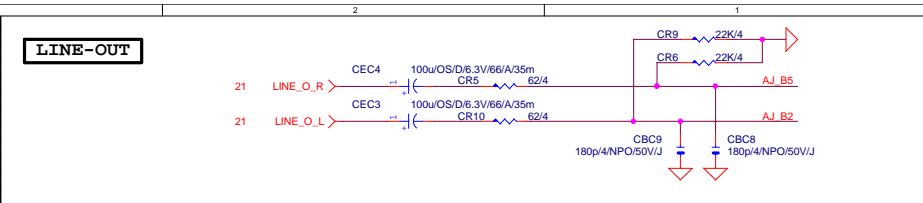
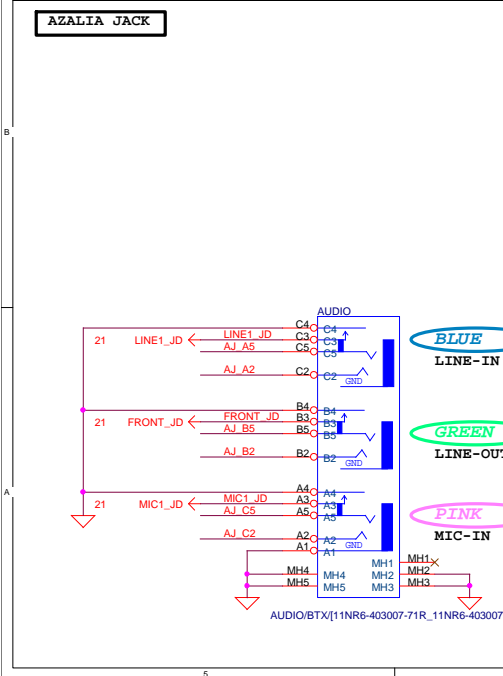
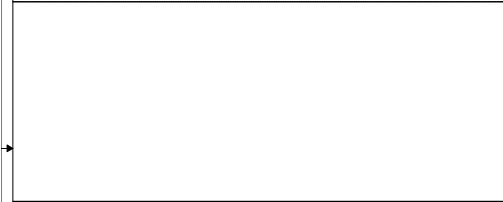
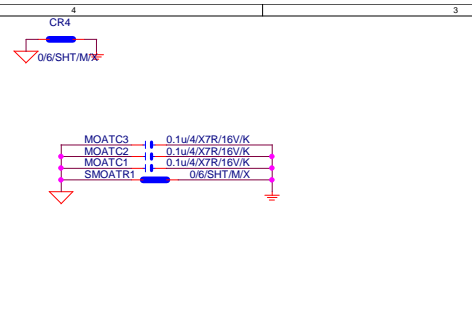
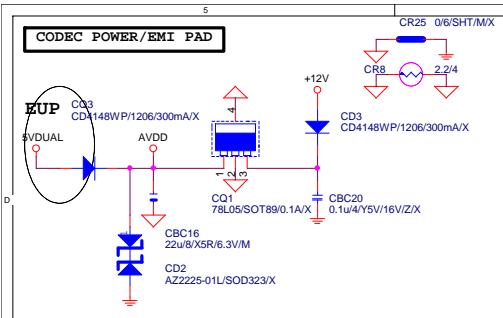

Gigabyte Technology		
AUDIO JACK		
GA-H61M-DS2		
Size	Document Number	Rev
Custom		2.01
Date:	Wednesday, November 30, 2011	Sheet 22 of 30

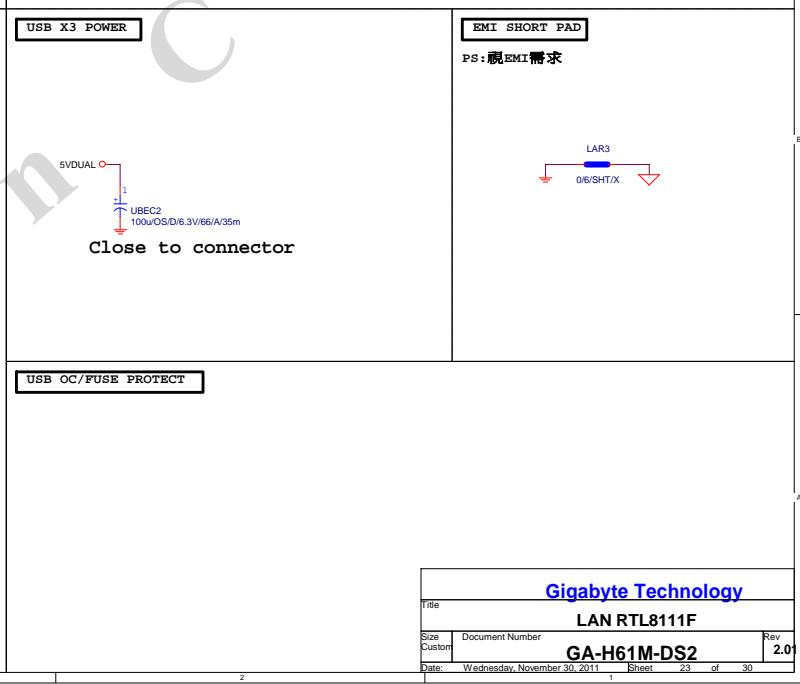
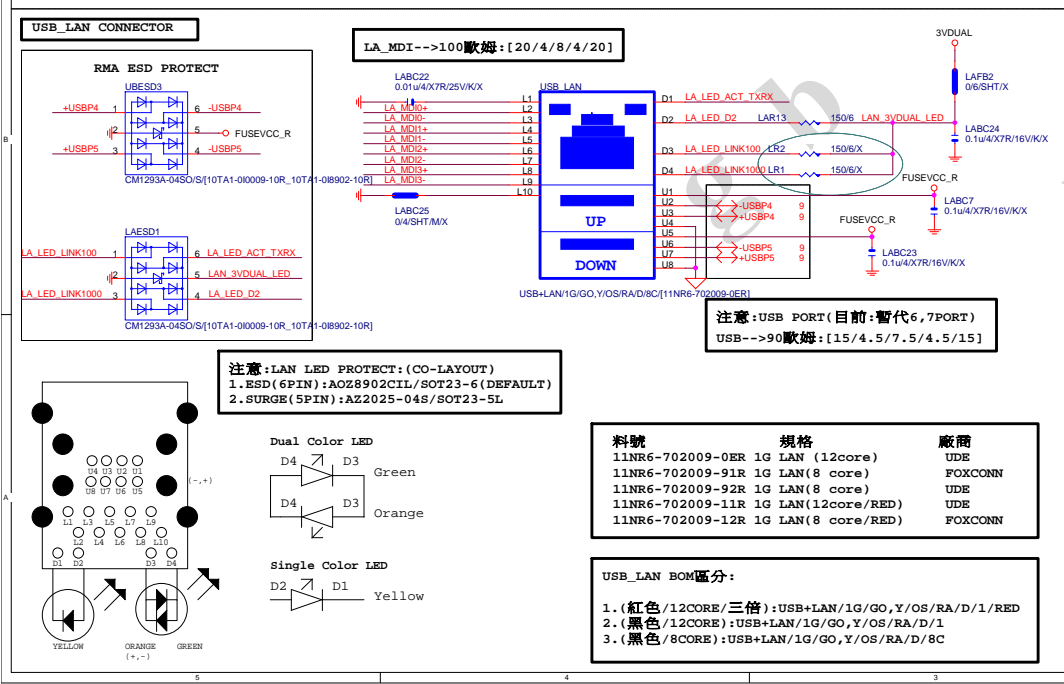
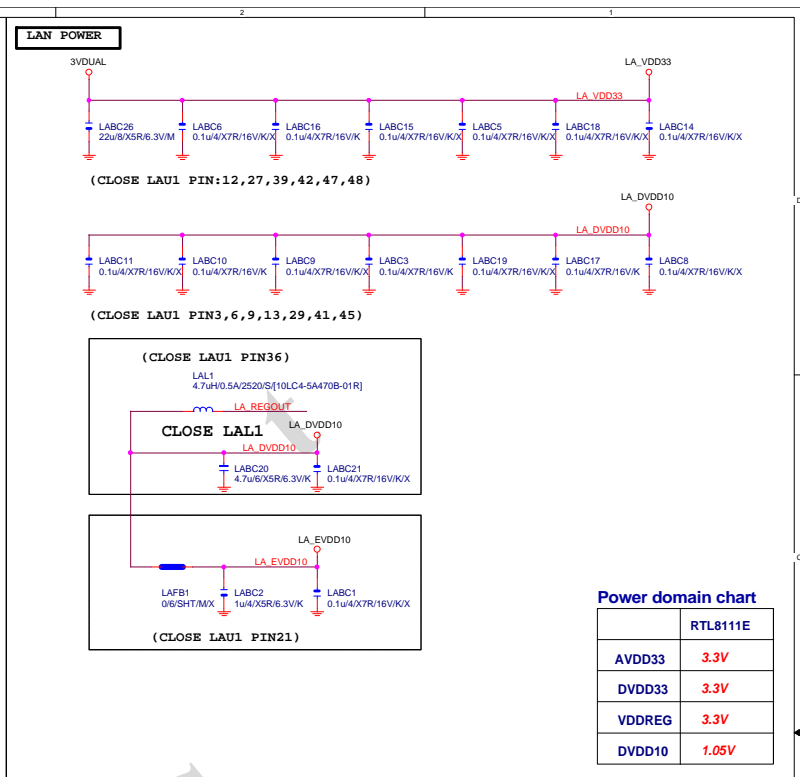
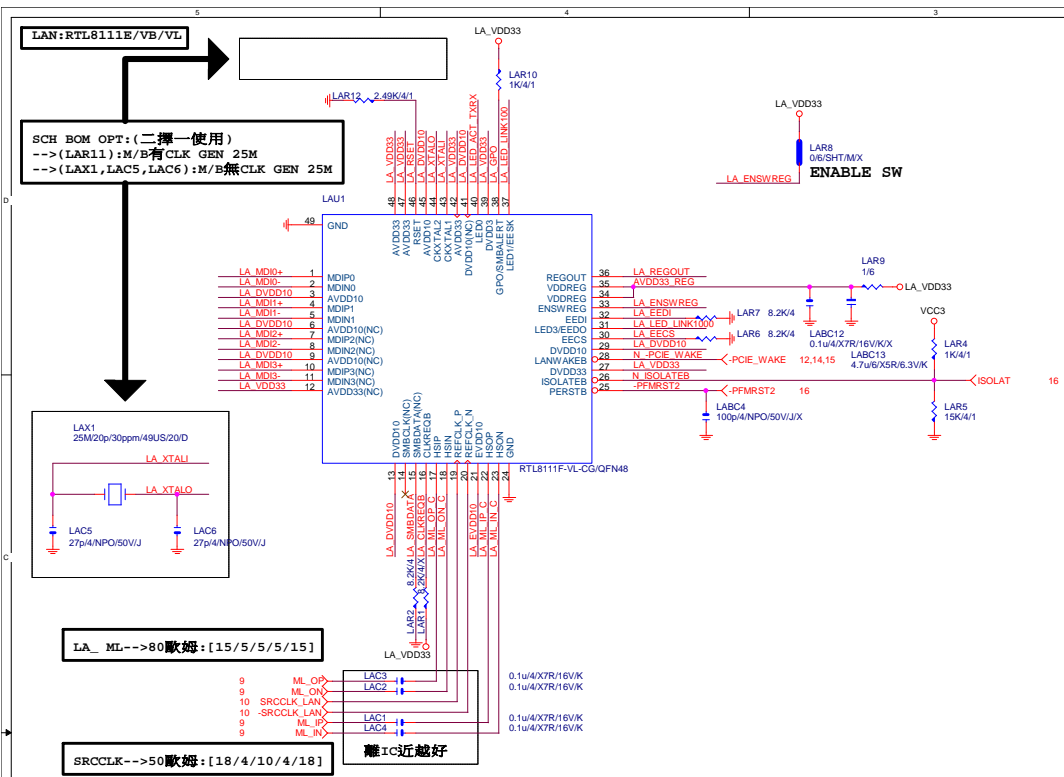

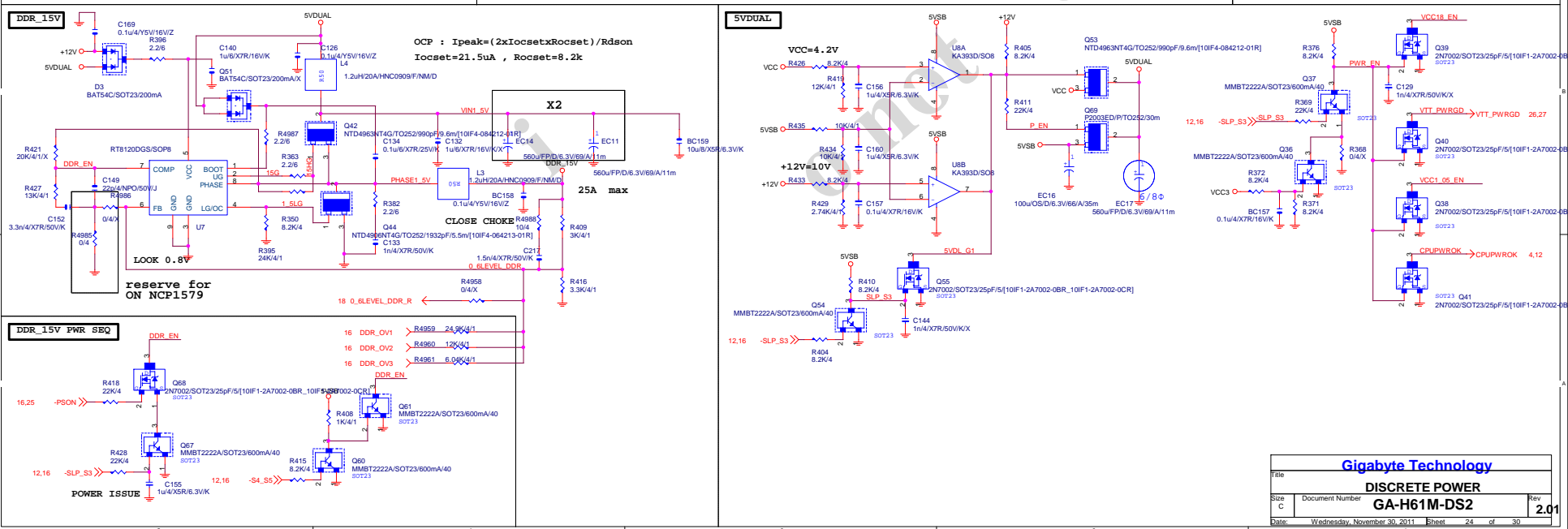
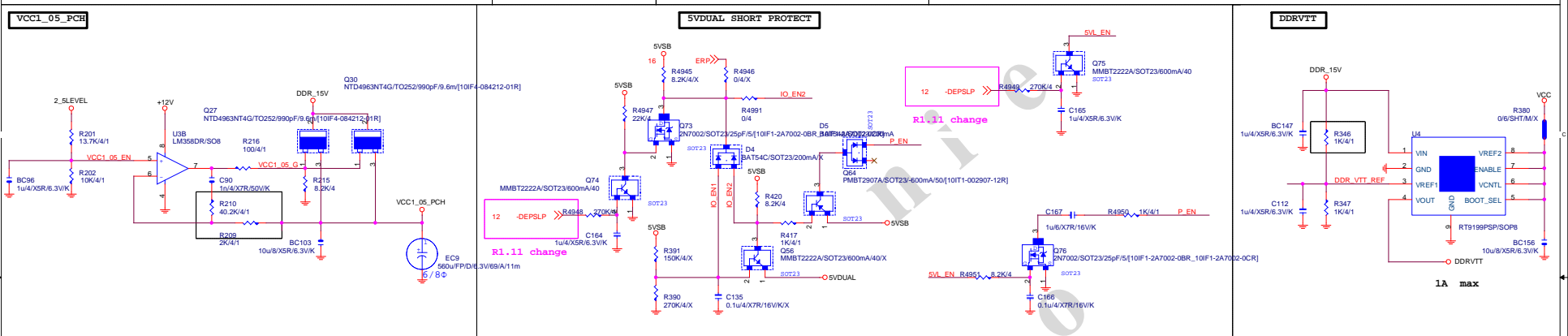
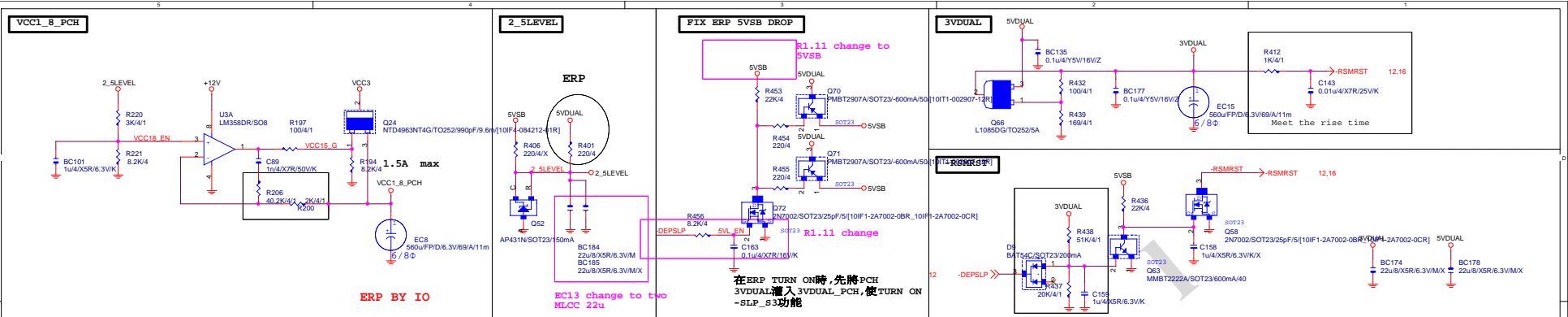

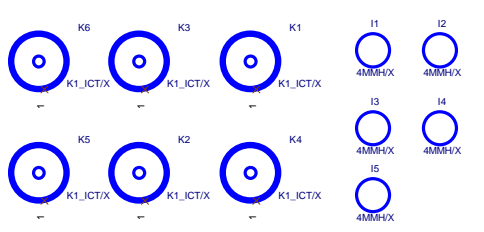
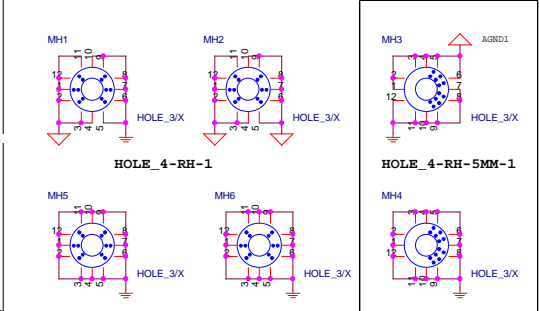
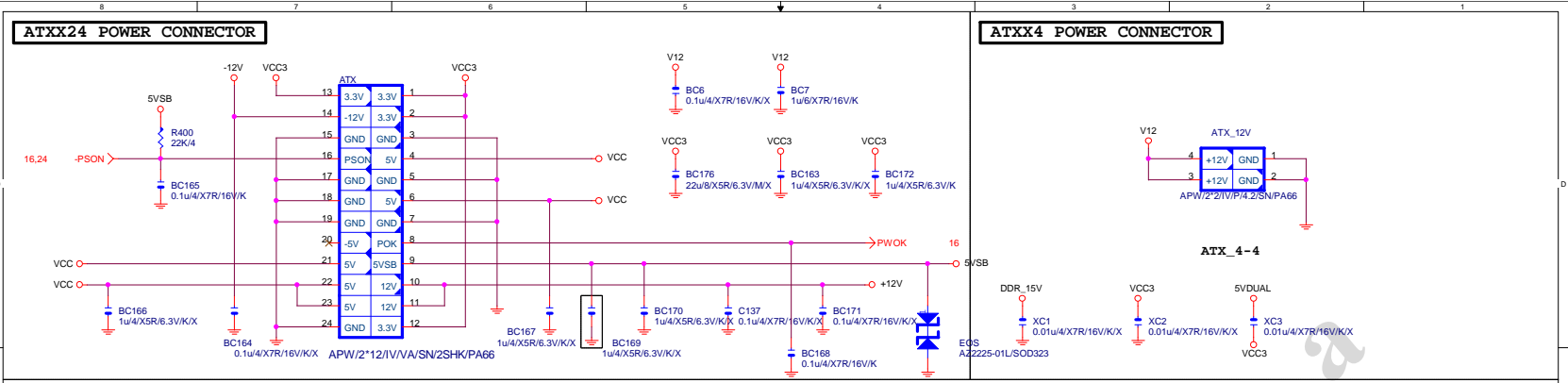

5VDUAL1(USB PORT/DDRIII POWER)
 5VDUAL (3VDUAL/OTHER)
 -S_WARN-->5VDUAL1-->-S_ACK (PCH) -->-DEPSLP / -RSMRST-->5VDUAL-->3VDUAL

HOLE_4-RH-5MM-1

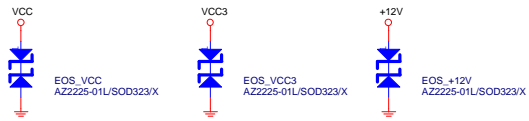

Gigabyte Technology		
File		
ATX CONNECTOR		
Size	Document Number	Rev
Custom	GA-H61M-DS2	2.01
Date:	Wednesday, November 30, 2011	Sheet 25 of 30

CPU_VTT

VTT OV option

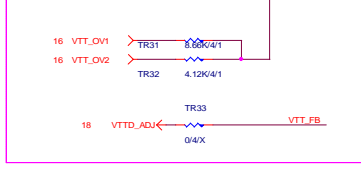

	VTT_EN
HI	ENABLE
LO	DISABLE

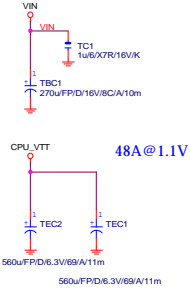
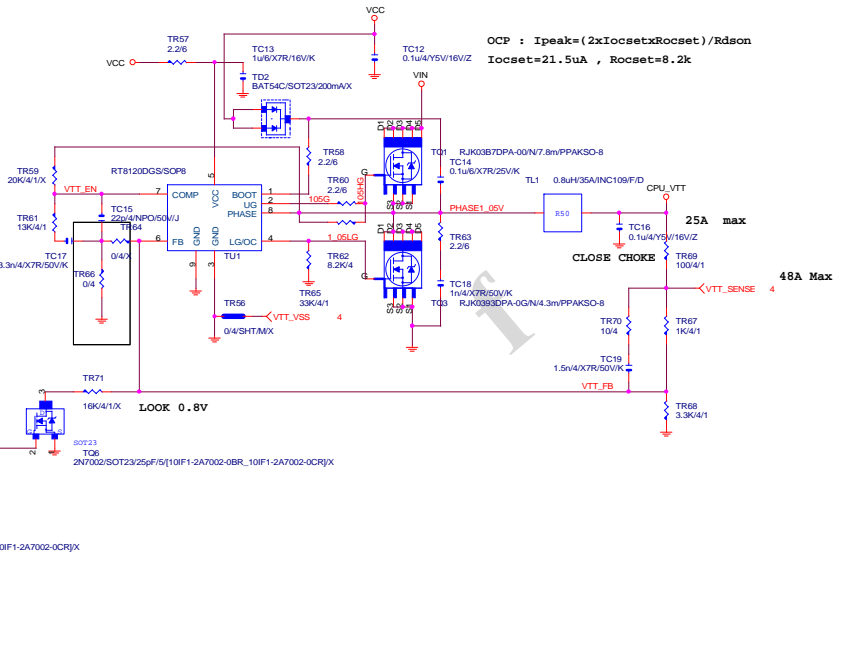

VCCSA

PDG 0.8

	VSA_SEL
HI	0.85V
LO	0.925V

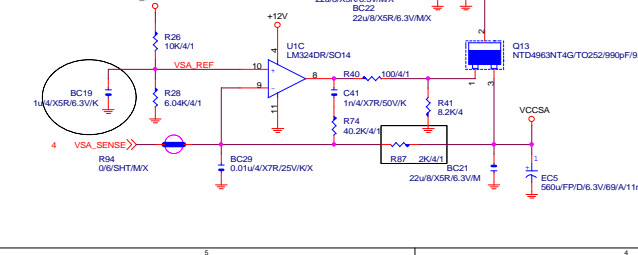

VCCSA_PWR_SEQ

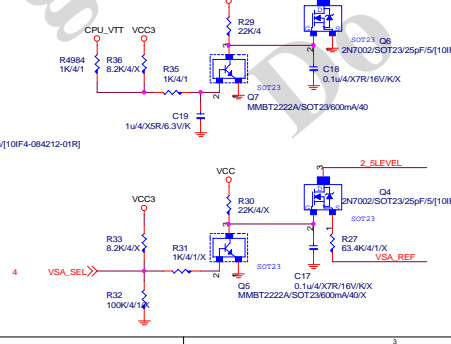

CPU_VTT_PWR_SEQ

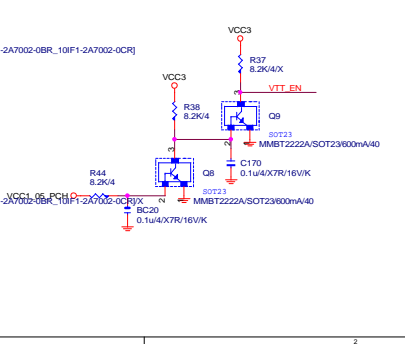

VTT_PWRGD

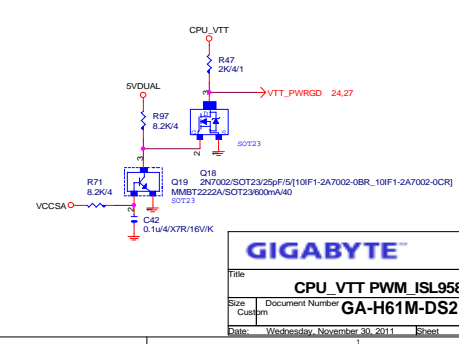

GIGABYTE

Title	CPU_VTT PWM_ISL95870CRZ	
Size	Document Number	Rev
1	GA-H61M-DS2	2.01
Date	Wednesday, November 30, 2011	Sheet 26 of 30

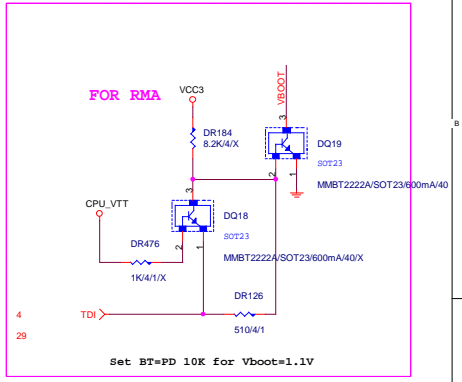
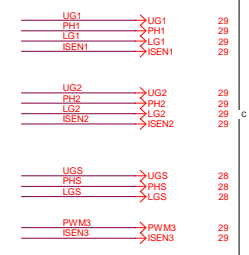
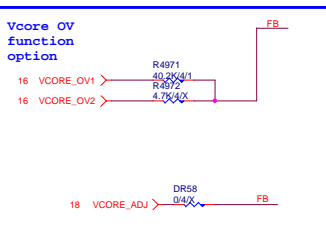
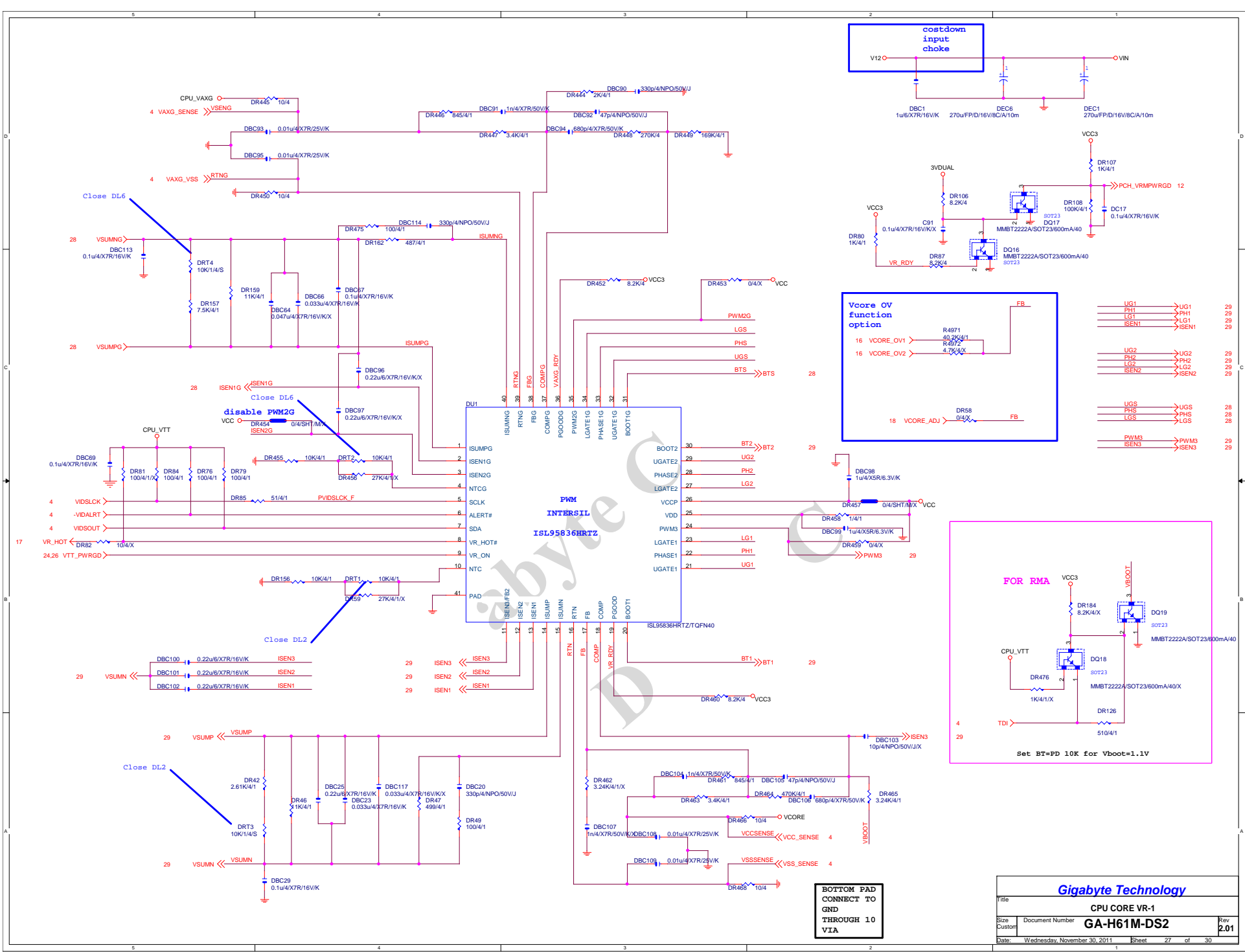

**BOTTOM PAD
CONNECT TO
GND
THROUGH 1.0
VIA**

Gigabyte Technology		
Title: CPU CORE VR-1		
Size: Custom	Document Number: GA-H61M-DS2	Rev: 2.01
Date: Wednesday, November 30, 2011	Sheet: 27	of 30

VAXG

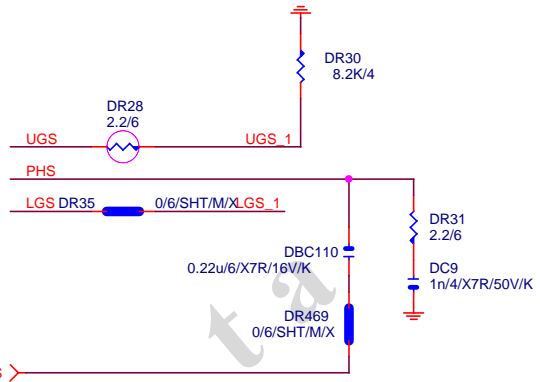
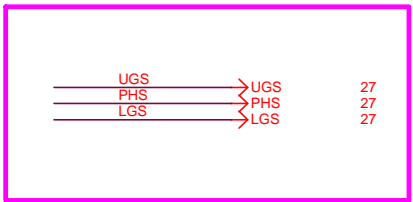

27 BTS

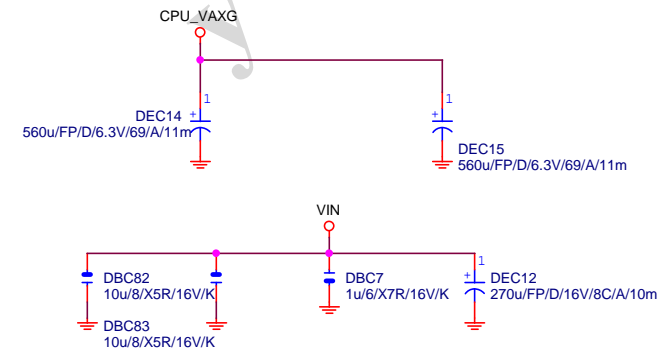
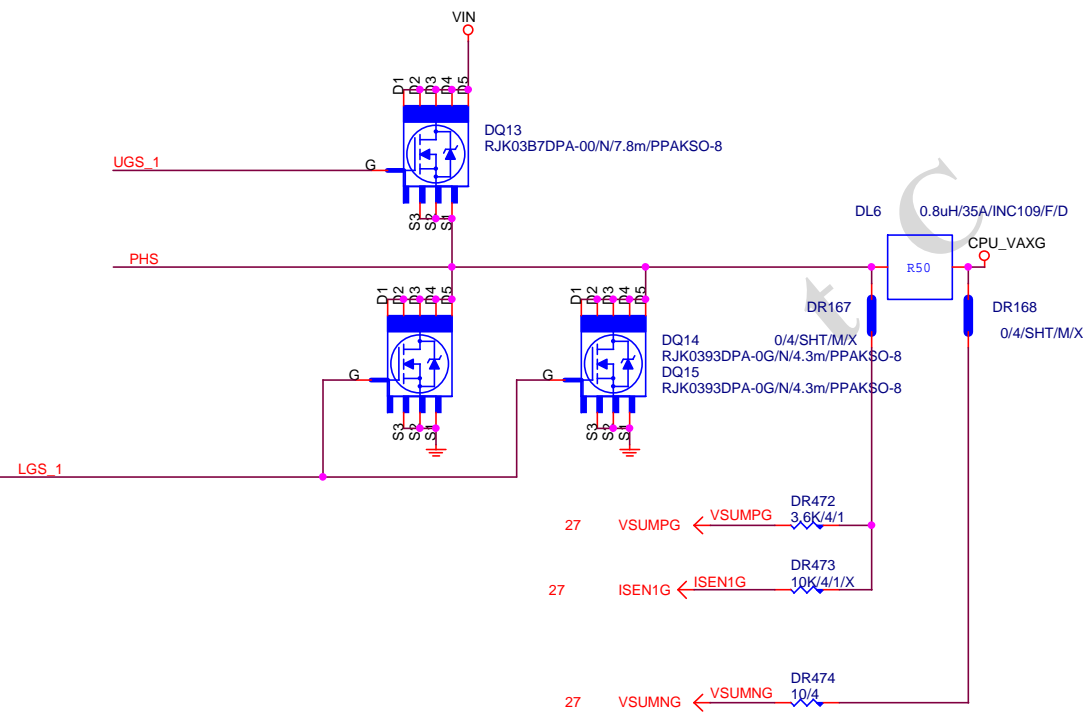

Gigabyte Technology

Title		
CPU CORE VR-2		
Size	Document Number	Rev
Custom	GA-H61M-DS2	2.01
Date:	Wednesday, November 30, 2011	Sheet 28 of 30

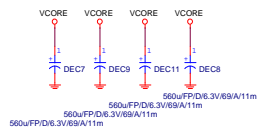
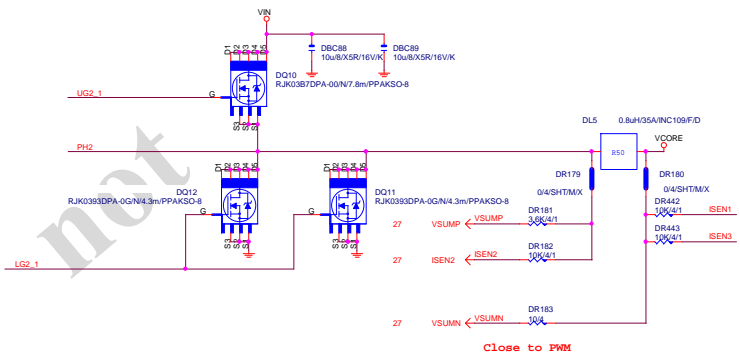
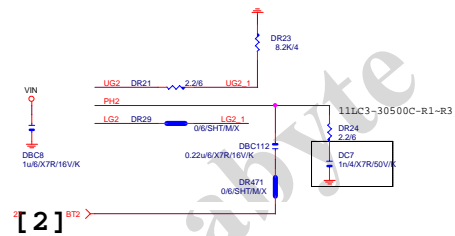
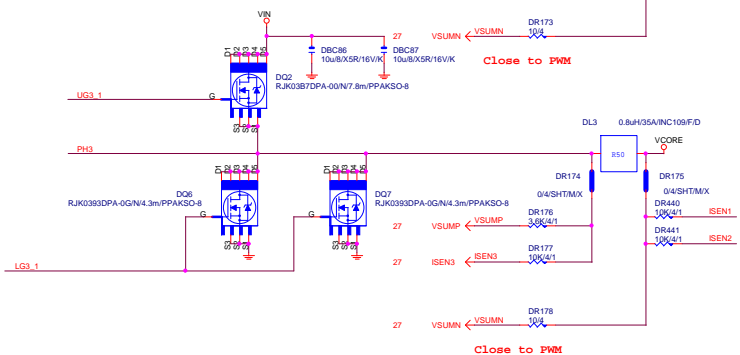
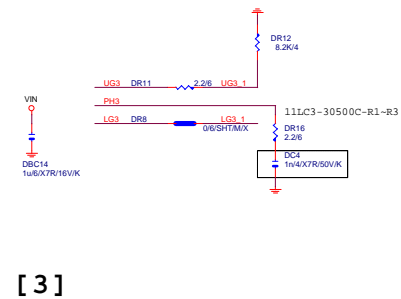
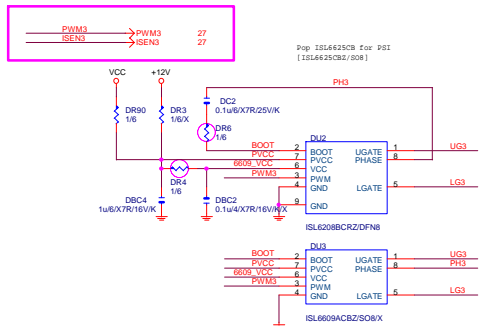
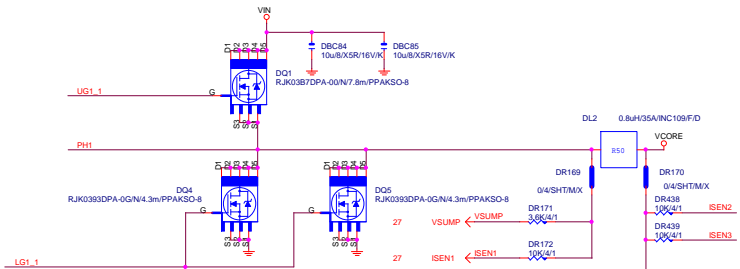
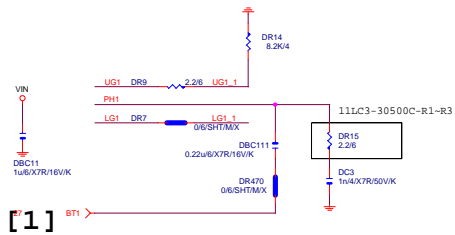

LPT PORT

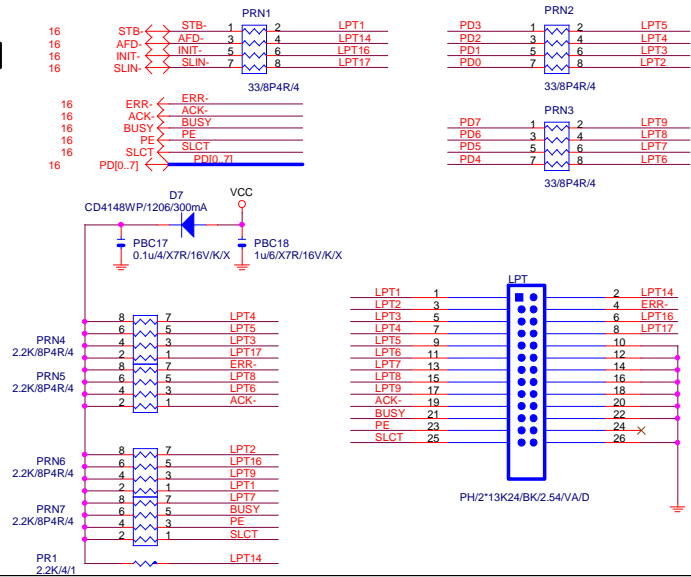

Gigabyte Technology			
Title: LPT			
Size: Custom	Document Number: GA-H61M-DS2	Rev: 2.01	
Date: Wednesday, November 30, 2011	Sheet: 30	of 30	